

*Dual color medium intensity NVG compatible (infrared night vision goggles)  
Comply with ICAO medium intensity dual color type A and B*

**48VDC flashhead**

Patents: EP 1966535B1 &amp; US 7816843

- 6 led projectors in aluminium and glass
- 2 white led circuits and a red with infrared circuit inside each projector
- NVG visible
- Simple installation with no losing parts when opening the flash-head
- Normally open or normally close relay in case of lamp default or power supply
- Communication capabilities (controller, Modbus TCP)
- Test button for day and night
- Luminous indicators for quick diagnostic
- 48Vdc surge protection with indicator showing when it has failed included
- GPS controlled or in back-up activated in case of failure or absence of an external controller or/and photocell

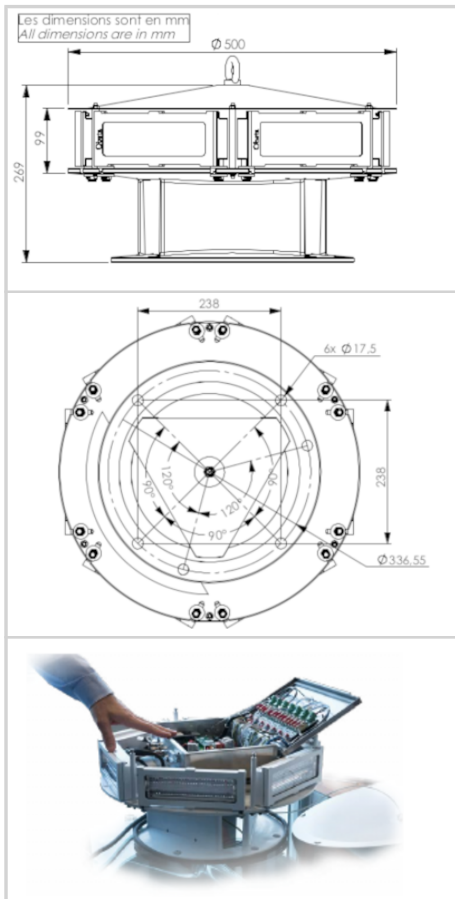

Electrical Characteristics	
Main voltage	48VDC -5%/+15% (max current 12A)
Average wattage	55W (day time), 8W (night mode)
Mechanical Characteristics	
IP degree	IP66 per projector
Wiring	Entry of cable by glands nickel plated brass and connection by terminals
Operating temperature	-40/+55°C
Size of the light	333mm (height) x 500mm (diameter)
Weight	19kg for flashhead
Cable entry diameter	11 to 21mm
Wire cross section	from 1 to 4 mm <sup>2</sup>
Attachment	6 mounting holes dia.16mm, dia.337mm circle (FAA standard)
Photometric Characteristics	
IR intensity and wavelength	> 600mW/sr @ 800-900nm
Effective light output day time at 0° on site	20 000cd (white)
Effective light output twilight mode at 0° on site	20 000cd (white)
Effective light output night mode at 0° on site	2000cd (red) with IR
Color day/twilight time	white
Color night time	Red
Vertical beam spread	>3°
Horizontal beam spread	360°
Flash per minute	40/30 as per FAA
Standards	
Standards compliance	ICAO annex 14 chapter 6, FAA (AC 150/5345-43J), UK MOD, Transport Canada