

Led navilite low intensity type A and B with IR visible by Night vision goggles. The NAVILITE-IR-48V includes 2 "de-coupled" visible and infrared circuits compliant with most of Aviation Authorities in Europe. The infrared part can be fixed or blinking as per the directive AD I-006 F from OFAC in Switzerland

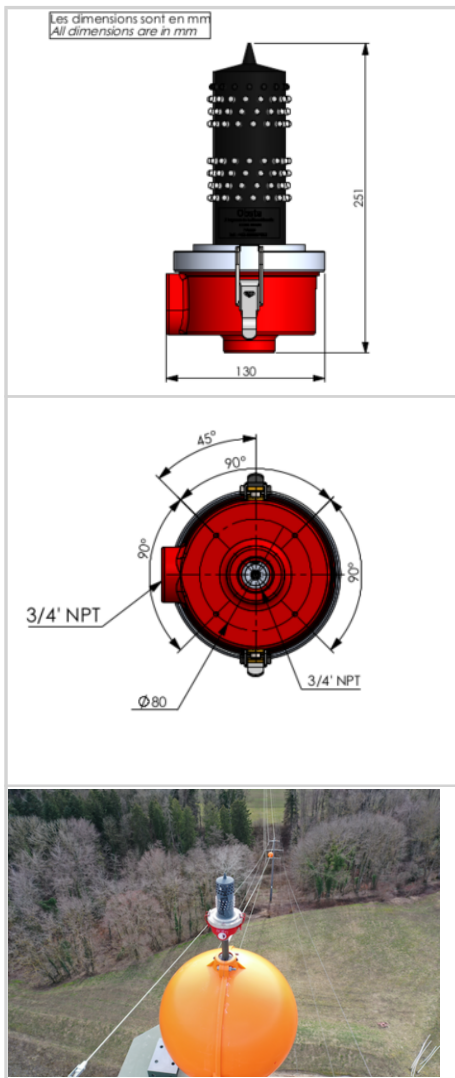

- Combi light low intensity as per ICAO + Night Vision Goggles compatible as per OFAC
- De-coupled red (fixed mode) and IR (blinking mode)
- Light part completely molded and waterproof
- Redundant circuits for LED's in both red and infrared
- 3/4" NPT threaded holes for mounting or with the "NAVILITE-L810-HOLDER"
- No losing part during installation
- Monitoring and power through a command box NAV-CMD-240 or NAV-CMD-048 with red fixed and infrared blinking according to Switzerland directive

Option Night Vision Goggles compatible as per OFAC



Electrical Characteristics	
Wattage	12W
Life time	~10years
Main voltage	48VDC ± 10%
Mechanical Characteristics	
IP degree	IP65 in vertical position
Wiring	On 4 stripped wires (2 power wires for each red and infrared led circuit)
Operating temperature	-40/+55°C
Weight	1,5 kg
Wire cross section	from 1 to 2,5 mm <sup>2</sup>
Attachment	2 NPT threaded holes
Photometric Characteristics	
IR intensity and wavelength	> 150mW/sr @ 850nm
Luminous intensity	> 35 Cd
Color night time	Red fixed
Vertical beam spread	>10°
Horizontal beam spread	360°
Standards	
Standards compliance	ICAO annex 14 chapter 6, directive AD I-006 F from OFAC