



RELIABILITY
IN OBSTRUCTION
LIGHTING

EDITION 9



POWERLINES

TELECOM

BROADCASTING TOWERS

CHIMNEY

AIRPORT

















WINDTURBINES

CONSTRUCTION



A blue-tinted cityscape at night, featuring several skyscrapers. The most prominent building in the center has a large UBS logo on its facade. The scene is overlaid with large, semi-transparent blue circular shapes. The text "RELIABILITY IN OBSTRUCTION LIGHTING" is centered in white, bold, sans-serif font.

RELIABILITY IN OBSTRUCTION LIGHTING

| | | | |
|---|---------------------------------|----|---|
|  | Introduction | 4 |  |
|  | Low Intensity lights | 20 |  |
|  | Medium Intensity lights | 36 |  |
|  | High Intensity lights | 52 |  |
|  | Balisors for transmission lines | 54 |  |
|  | Warning spheres | 56 |  |
|  | Bird diverter, Diagnostic SNMP | 58 |  |
|  | Solar kits, Helipad (TLOF) | 60 |  |



Company history

OBSTA, a subsidiary of CITELE group (www.citel.fr) is part of an industrial group that engineers, manufactures and sells obstruction lights for transmission lines, telecom, broadcasting towers and all kind of obstacle to air navigation since more than 30 years. Our obstruction lights are manufactured by us compliant with ICAO annex 14 chapter 6 (International Civil Aviation Organization) recommendations and the FAA (Federal Aviation Administration).

OBSTA has manufacturing facilities in France and has sales offices located in France, Germany, USA, and China through Citel.



A long history

Before joining Citel in the years 90, Obsta was part of the company Claude that was manufacturing all kind of lamps. This company was created by Georges Claude (September 24th 1870 – May 23th 1960) a French physicist and chemist :



1902 : Extraction of rare gas from the air (neon, argon, xenon..) and creation of the company Air liquide

1910 : Invention of the first modern patented discharge lamp tube and creation of Claude company manufacturing all kind of discharge and incandescence lights

1960 : Invention of the first balisors for transmission lines

1992 : Bought by Citel manufacturing gas tube and surge protection

2003 : New led NAVILITE obstruction lights red fixed

2008 : New obstacle light with linear optic for discharge and LED lights.

2012 : New medium and high intensity LED lights.

Specialist in obstruction lighting

Over the years, three large product families (neon xenon and led type) have been developed in the respect of the most severe standards, requested by our customers. OBSTA lights are designed in the respect of the latest international standards that are ICAO and FAA. They constitute a complete range of low intensity or L-810, medium intensity or L-865/L-864 and also high intensity obstruction lights, ideal for broadcasting towers, telecom mast, transmission lines, stacks and wind turbines.

- Cold neon discharge lights,
- pure cold neon discharge 5 and 13 turns OBSTA® HI STI & STI,
- 33 & 49 turns BALISOR® (conductor warning lights) red fixed obstruction lights.



Led NAVILITE® red fixed obstruction lights (low intensity and L-810) since 2003 The NAVILITE series is dedicated to night only obstruction lights especially for telecom mast, buildings close to airports and all kind of obstacle below 45 meters high. Completely molded with 64 leds divided in 16 independent led circuits, they are ideal for all kind of obstacle



- Led and Xenon OBSTAFLASH : OBSTAFLASH white and red flashing for high structures medium intensity type A and B/C, L-865/L-864, L-865, L-864 and L-810. High intensity type A and B



Test facilities

In order to test its products internally for standards compliance and to evolve toward greater reliability OBSTA has several test sites (France, USA) equipped with :

- Photometric band with visible and infrared capability
- 1.2/50-8/20 μ s hybrid wave generators up to 20 kV/10 kA
- HT digital Oscilloscope fast
- Material for test environment (damp heat, climate, shock)

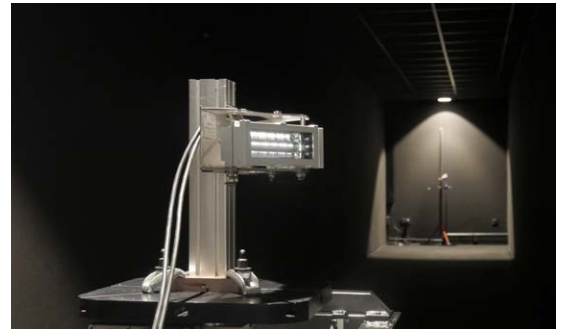

An international company

Obsta is part of CITEC group with international commercial subsidiaries.



Sèvres -
 Head Office - France and
 Export Sales Office



Reims -
 Production plant
 and logistics platform

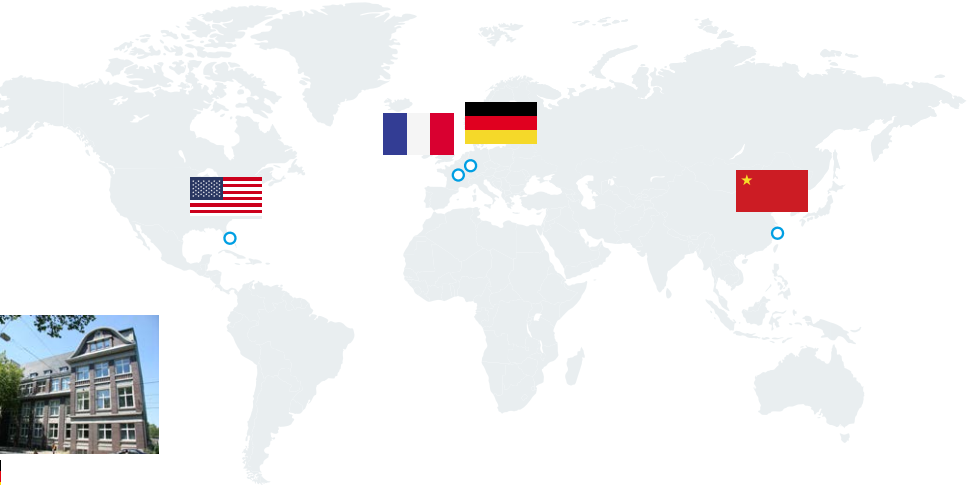



Any object which could represent a hazard for low-flying aircraft must be marked by beacon lights. The ICAO (International Civil Aviation Organization - appendix 14, Chapter 6) and the FAA (Federal Aviation Administration - USA) lay down internationally-applicable rules on the characteristics of the beacons and their installation.

Some points of the regulations (depending on the type of obstacles which must be marked), and the corresponding installation rules, are given below.

| Intensity | Color | Type | | flashes per minute | Night (Cd) | Day (Cd) | Twilight (Cd) |
|-----------|------------|-------|---------------|--------------------------------|-------------|----------------|---------------|
| | | ICAO | FAA | | | | |
| LOW | Red | B | L-810 | Steady or flashing with L-864 | ≥ 32.5 | light OFF | |
| MEDIUM | Red | B | L-864 | 30 fpm | 2,000 ± 25% | light OFF | |
| | Dual Color | A & B | L-865 / L-864 | 40 fpm (white) 30 fpm (red) | 2,000 ± 25% | 20,000 ± 25%* | 20,000 ± 25%* |
| | White | A | L-865 | 40 fpm | 2,000 ± 25% | 20,000 ± 25%* | 20,000 ± 25%* |
| HIGH | White | A | L-856 | 40 Fpm | 2,000 ± 25% | 270,000 ± 25%* | 20,000 ± 25%* |

* : FAA requires a flash duration of 100ms max with Blondel-Rey formula for effective intensity.
NVG compatible for L-810 and L-864 lights

Extract from annex 14 ICAO

Extract from table 6-3. Characteristics of obstacle lights

Position of the obstruction lights

6.3.11 One or more low-, medium- or high intensity obstacle lights shall be located as close as practicable to the top of the object. The top lights shall be so arranged as to at least indicate the points or edges of the object highest in relation to the obstacle limitation surface.

6.3.12 Recommendation - In the case of chimney or other structure like function, the top lights should be placed sufficiently below the top so as to minimize contamination by smoke etc...

6.3.14 In the case of an extensive object or of a group of closely spaced objects, top lights shall be displayed at least on the points or edges of the objects highest in relation to the obstacle limitation surface, so as to indicate the general definition and the extent of the objects. If two or more edges are of the same height, the edge nearest the landing area shall be marked. Where low-intensity lights are used, they shall be spaced at longitudinal intervals not exceeding 45 m (150ft). Where medium-intensity lights are used, these shall be spaced at longitudinal intervals not exceeding 900 m (2950ft)

6.3.15 Recommendation - When the obstacle limitation surface concerned is sloping and the highest point above limitation surface is not the highest point of the object, additional obstacle lights should be placed on the highest point of the object.

6.3.22 The number and arrangement of low-, medium- or high-intensity obstacle lights at each level to be marked shall be such that the object is indicated from every angle in azimuth. Where a light is shielded in any direction by another part of the object, or by an adjacent object, additional lights shall be provided on that object to be lighted. If the shielded light does not contribute to the definition of the object to be lighted, it may be omitted.

In order to help you choosing the proper light you need, you will find below the most common configurations. The recommendations and rules mentioned below **are only given for information based on the ICAO recommendations, and ICAO aerodrome design manual.**

Night time marking (Red only)

The night time marking is done with **red obstruction lights**:

- low intensity type A or B (L-810)
- and/or medium intensity type B (L-864)

Day time marking (White flashing only)

The day time marking is done with **white flashing obstruction lights**:

- medium intensity type A (L-865)
 - or high intensity type A or B (L-856, L-857)
- (For obstacle below 150 meters the use of white strobe flashing light during day time eliminate the need to paint the obstacle with red and white stripes).

Day and night time marking (White flashing or Dual Color)

The day and night time marking can be realized by using either:

- white medium intensity light working day and night
- dual color lights, white flashing during day time and red during night time



Obstruction light choices

| ICAO | OBSTA designation | OBSTA part number | Compliance statement |
|---|--|-------------------|--|
| Low intensity type A (red steady burning) | NAVILITE-SOL, OBSTA-STI-48V, OBSTA-STIF-12V, BALISOR 63KV to 500KV | all | ICAO compliant (7th Edition_July 2018) EASA (European Aviation Safety Agency) |
| Low intensity type B (red steady burning) | NAVILITE-48V, NAVILITE-24V, NAVILITE-12V, NAVILITE-230; NAVILITE-120-240 | | |
| Low intensity type B (red steady burning) + infrared (fixed or flashing) | Combi light NAVILITE-RI-48V | | |
| Medium intensity type A (white flashing), type B (red flashing), type C (red steady burning) and dual color | Obstaflash medium intensity series | | |
| High intensity type A (white flashing) | OFH-120 | | |
| Medium intensity type A + feuer W rot | OF360-FW-240 | 113735 | Verified by Ministry of Transportation of Germany |

| FAA & ICAO type | OBSTA designation | OBSTA part number (FAA) | Compliance statement |
|---|---|--|--|
| L-810 Low intensity type B | NAVILITE-FAA | 113969IR | FAA (150-5345-43J) ETL certified + compliant with ICAO low intensity type B |
| L-865 Medium intensity type A (white flashing light) | Obstaflash OF360-WW-240-U; OFI360-WW-240-U; OFI120-WW-048-U; OFI120-WW-048/240-U; OFI120-WW-240-U; OFI-WW-048-U | 113723U; 113723UI; 113711U; 113757U; 113713U; 113791U | FAA (150-5345-43J) L-865 ETL certified + compliant with ICAO medium intensity type A |
| L-864 Medium intensity type B (red flashing light) | Obstaflash OF360-R-240; OFI360-R-240; OFI120-R-048-U; OFI120-R-048/240-U; OFI120-R-240-U; OFI-R-048; OFC-RR-240; OFC-RR-048 | 113724; 113724I; 113710U; 113756U; 113714U; 113790; 113790RR-240; 113790RR-048 | FAA (150-5345-43J) L-864 ETL certified + compliant with ICAO medium intensity type B |
| L-865/L-864 Dual color medium intensity type A and B | Obstaflash OF360-RW-240-U; OFI-RW-240-U; OFI120-RW-240-U; OFI120-RW-48/240-U; OFI120-RW-048-U; OFI360-RW-048-U | 113725U; 113725UI; 113715U; 113758U; 113712U; 113792U | FAA (150-5345-43J) L-865/L-864 ETL certified + compliant with ICAO medium intensity type A & B |
| L-864 OFC Medium intensity type B (red) | Combi lights OFC-RI-240; OFC-RI-048 | 113790RI-240; 113790RI-048 | FAA (150-5345-43J) L-864 ETL certified + compliant with ICAO medium intensity type B |
| L-856 High intensity | Obstaflash OFH-120-WW-240-U | 113780U | FAA (150-5345-43J) L-856 pending |

Led NVG compatible obstruction lights

All our medium intensity or high intensity (red or dual color mode) are Night Vision Compatible as per FAA AC 150/5345-43J. Only our low intensity and L-810 remains available in 2 options: with or without infrared

Those energy-saving LED lights are providing years of operation and are maintenance-free. They are also NVG friendly : Aviation authorities such as FAA, CAR (Canadian Aviation Regulation), MOD (UK) and OFAC (Switzerland) have issued safety alerts warning that common LED obstruction lights pose a hazard to pilots using Night Vision Goggles (NVGs). This is due to the fact that NVGs typically use filters to block cockpit lighting from saturating the imaging system. This has the unintended effect of making LED obstruction lights invisible to pilots.

In response, Night Vision Goggles based on infrared technology provide pilots using night vision goggles unmatched visibility of airfield perimeters, buildings, wind turbines and towers. Our FAA led obstruction lights ensure that your structure remains visible to all pilots.



Night Vision Goggles compatible according to FAA & OFAC directive (Switzerland)



BUILDING (see diagram p 10-11)

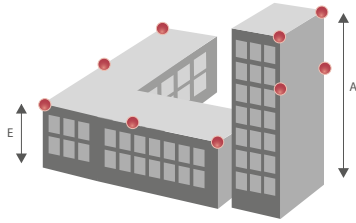

| Height | Night marking (red lights working at night only) | Day and Night marking (white flashing light for day mode and red lights for night mode) |
|--------------------------------------|--|---|
| Below 45m (150ft) | Low intensity lights type A on the perimeter of the building every 45 meters maximum | Low intensity type A on the perimeter of the building every 45 meters max. with medium intensity type A working during day time only |
| 45m (150ft) and above | Medium intensity type B at the top with eventually intermediate levels of low intensity type B and medium intensity type B if the building is not masked by other construction | Dual color medium intensity type A+B (white during the day and red during the night) at the top with optional low intensity type B at intermediate levels if the building is not masked by other construction |
| In option: 150m (500ft) and above | Alternative: above a height of 150m (500ft) high intensity lights every 105m (350ft) maximum. | |

Note : Intermediate levels are recommended only if there are higher than the top fo nearby buildings.

POLE / TOWER (see diagram p 12-13)

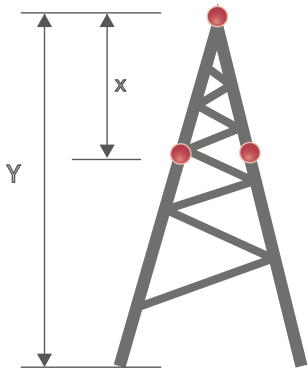

$$\text{Number of lights} = N = \frac{Y(m)}{45}$$

$$\text{Distance between lights} = X = \frac{Y}{N} < 45m$$

| Height | Night marking (red lights working at night only) | Day and night marking (white flashing light for day mode and red lights for night mode) |
|--------------------------------------|--|---|
| Below 45m (150ft) | 1 or 2 low intensity type A or B at the top (L-810) | 1 or 2 white medium intensity type A (L-865) at the top of the pole with low intensity working at night |
| 45m (150ft) and above | 1 or 2 medium intensity type B at the top with intermediate levels of medium intensity type B every 105 meters max., with low intensity type B in between each level of medium intensity | 1 or 2 dual color medium intensity type A+B at the top with intermediate levels of dual color medium intensity type A+B every 105m max., with low intensity type B in between each level of medium intensity. |
| In option: 150m (500ft) and above | High intensity type A at the top with intermediate lights every 105 m maximum working during day time only and red low intensity type B and medium intensity type B working at night only. White flashing lights type A can also work day and night. | |

STACK (see diagram p 14-15)

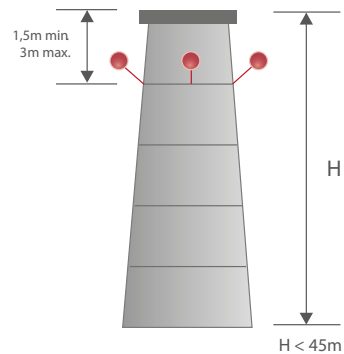

| Height | Night marking (red lights working at night only) | Day and Night marking (white flashing light for day mode and red lights for night mode) |
|--------------------------------------|---|---|
| Below 45m (150ft) | 3 low intensity type A below the top of the stack | 3 low intensity type A working at night only and medium intensity type A working during daytime only. The lights should be below the top of the stack |
| 45m (150ft) and above | 3 medium intensity type B below the top of the stack with optional intermediate level of low intensity type B every 45 meters high around the stack | 3 dual color medium intensity type A+B (white during the day and red during the night) below the top of the stack, with in option 3 or more low intensity type B at intermediate levels at the top of stack |
| In option: 150m (500ft) and above | Alternative: above a height of 150m (500ft) high intensity lights every 105m (350ft) maximum. | |

Note : for stack with diameter between 6 and 30 meters, 4 lights per level are required. For stack with diameter between 30 and 60 meters, 6 lights are required per level. And for stack with diameter above 60 meters, 8 lights per level are required per level.



CRANE (see diagram p 16)

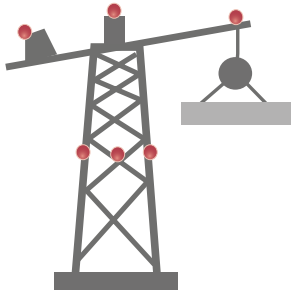

| Height | Night marking only | Day marking |
|-----------------------|--|--|
| Below 45m (150ft) | Low intensity type A at the top of the crane-top and at each extremity of the jib and counter jib. | 1 medium intensity dual color at the top of the crane-top. |
| 45m (150ft) and above | 1 medium intensity type B (L-864) at the top of the crane-top. | |
| 105 m and above | | |

WIND TURBINE (see diagram p 17)



| Night marking only | Day and night marking |
|---|---|
| 1 or 2 Medium Intensity type B (L-864) | 1 or 2 Medium Intensity dual color type A+B (L-865/L-864) |

TRANSMISSION LINES (see diagram p 18)

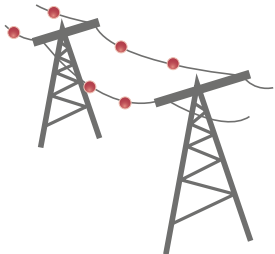

| Height | Night marking only | | Day marking only |
|--------------------|--|---|--|
| Poles | Same configuration than in the first case «pole and tower» | If it is not possible to install a light on the poles, 2 Balisors placed on each side of the pole at 10m (30ft) maximum and placed on the highest cable | Same configuration than in the first case «pole and tower» |
| High voltage cable | Balisors every 70m (230ft) near airport and every 105m (350ft) in other cases. | | Warning spheres of 600mm diameter (2ft) every 30m (100ft) |

In the case of an extended obstacle (wind turbine farm, cranes, etc...) the beacons need to be synchronized. Beacons need to be backed up with a 12hour battery life in case of a loss of the main power line.



OBSTRUCTION LIGHTING FOR AIRPORT

Use case for an airport with building below 45 meters high except control tower higher than 45 meters

1 WHITE THE DAY / RED AT NIGHT



OBSTAFASH DUAL COLOR
Medium Intensity White & Red
L-865/L-864

2 ONLY AT NIGHT



NAVILITE 230 VAC
Low intensity
every 45 meters

or

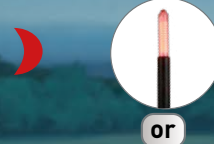

neon HISTI 110 to 240 VAC
Low intensity
every 45 meters

or



NAVILITE FAA L810 IR
Low intensity
every 45 meters





OBSTRUCTION LIGHTING FOR BUILDINGS

Three typical configurations depending on height

- 

1 OBSTAFLASH RED COMPACT
Medium Intensity Red only
- 

2 OBSTAFLASH DUAL COLOR
Medium Intensity White & Red
- 

3 OBSTAFLASH 120° or 180°
Medium Intensity White & Red

- 

4 NAVILITE
Low Intensity Red

- 

5 OBSTAFLASH HI
High Intensity White

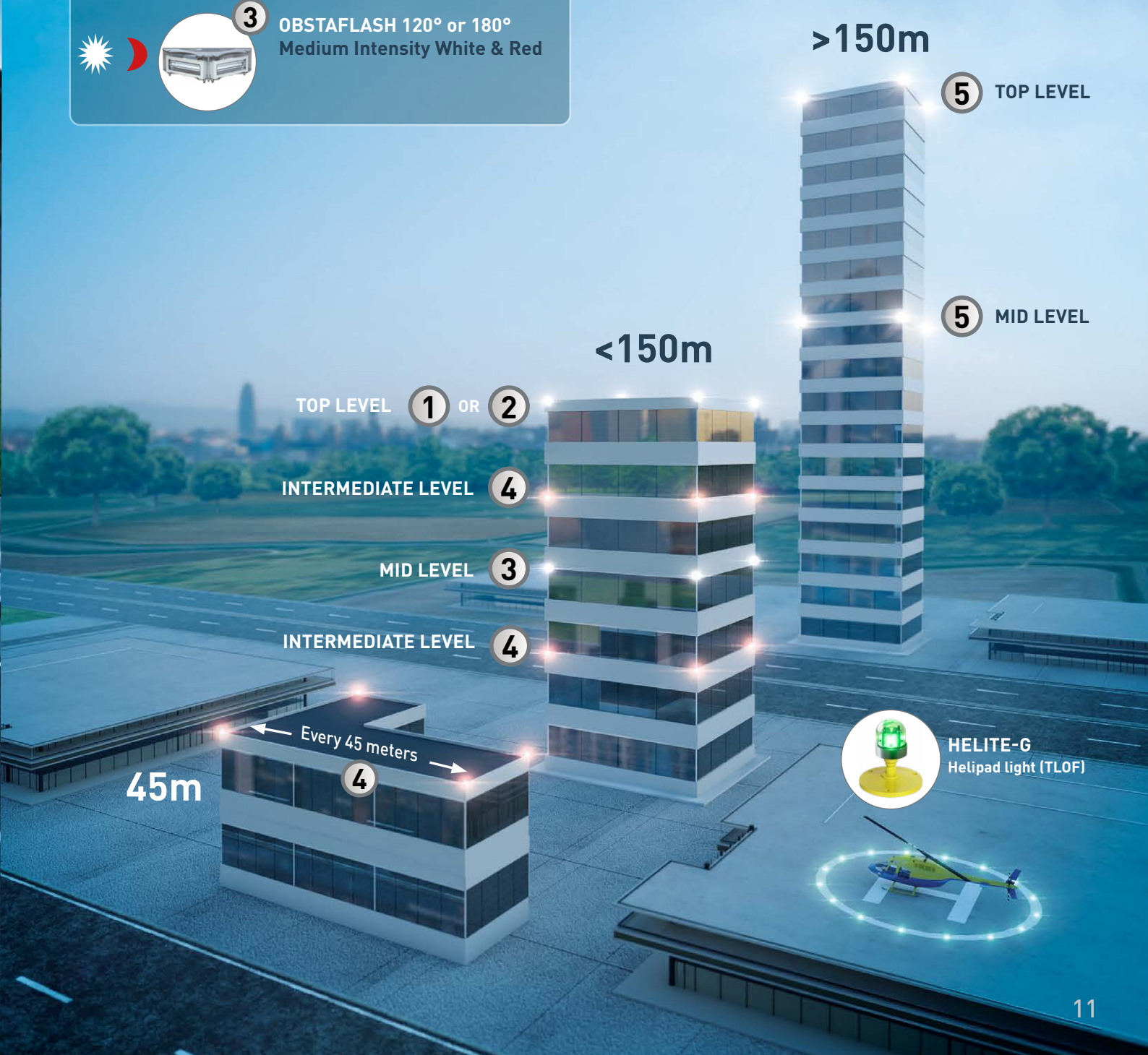



OBSTRUCTION LIGHTING FOR TOWER

Towers from 105m to 150m
Day and night operation.

(The use of white flashing light during the day eliminates the need to paint the tower)

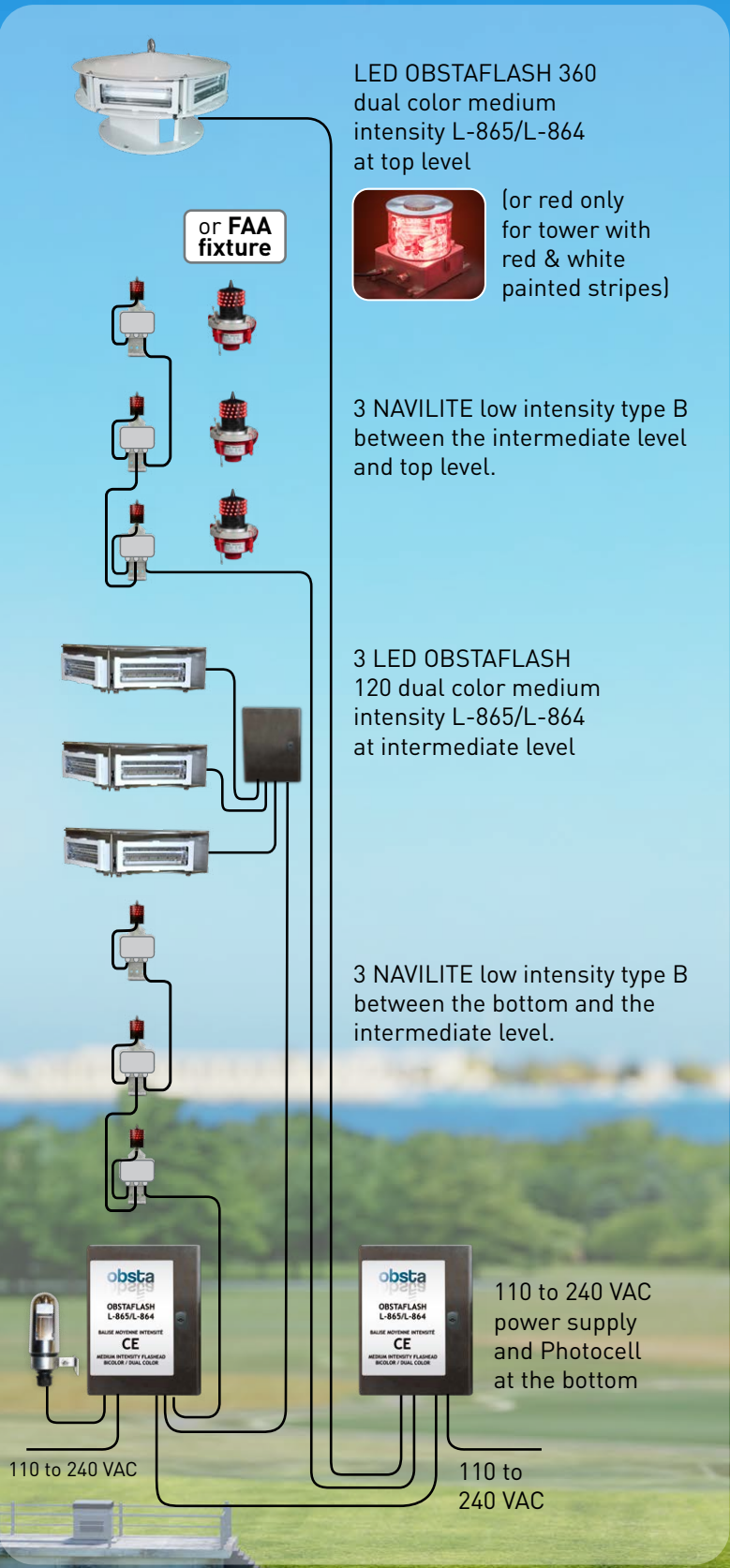
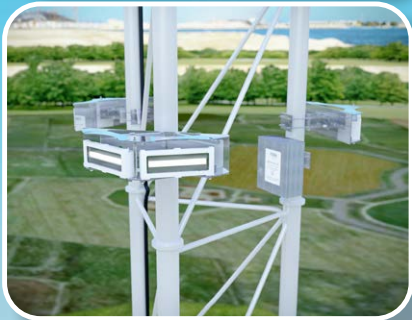

OBSTRUCTION LIGHTING FOR TOWERS

Use cases for towers from 45m to above 105m
Night only operation

- 

1 OBSTAFASH RED COMPACT
Medium Intensity Red only
- 

2 OBSTAFASH 120° or 180°
Medium Intensity Red
- 

3 NAVILITE FAA
Low Intensity Red

UP TO 45M

3 MID LEVEL

105-150M

1 TOP LEVEL

3 INTERMEDIATE LEVEL

46-105M

1 TOP LEVEL

1 OR **2** MID LEVEL

3 MID LEVEL

3 INTERMEDIATE LEVEL

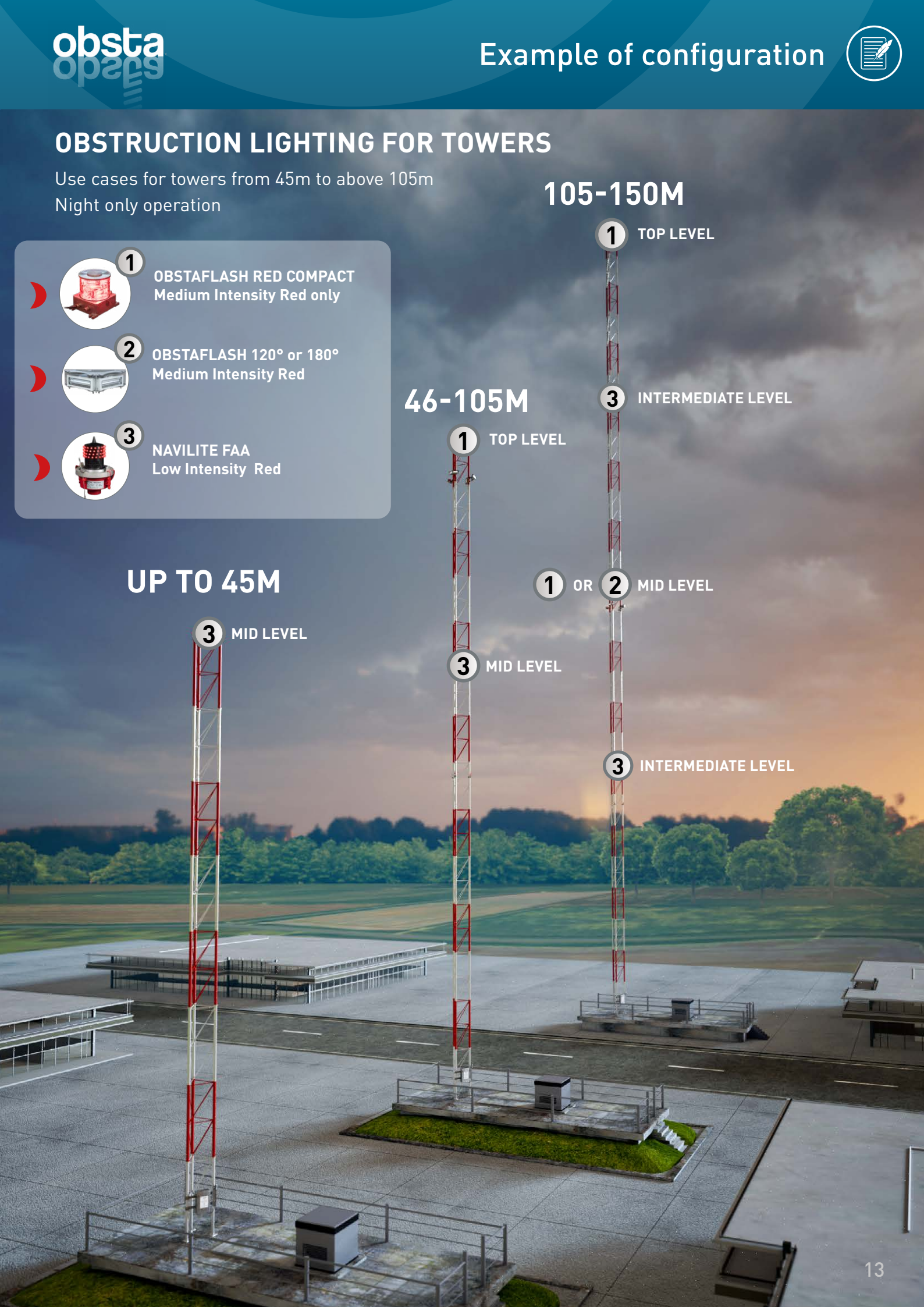



OBSTRUCTION LIGHTING FOR STACK

Stack without red & white stripes 45 to 105 meters high. Lights operating Day and night.



3 LED OBSTAFLASH120 dual color medium intensity ICAO compliant and L-865 / L-864 FAA ETL verified below the top to avoid the smoke to hide the lights



3 NAVILITE at mid level



ICAO low intensity type B **Or** FAA L-810 type with NPT pipe

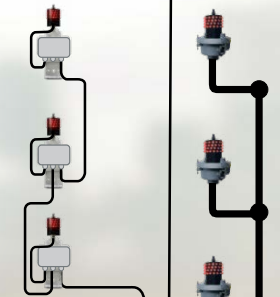

110-240 VAC power supply and Photocell at the bottom with or without batteries



Photocell north oriented



110 to 240 VAC

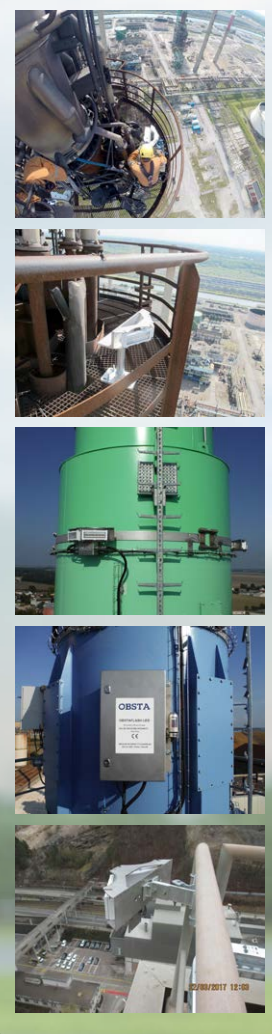



OBSTRUCTION LIGHTING FOR STACK

Painted stack (red & white stripes) 45 to 105 meters high, lights operating only at night.

Number of lights per level depending on the diameter of the chimney

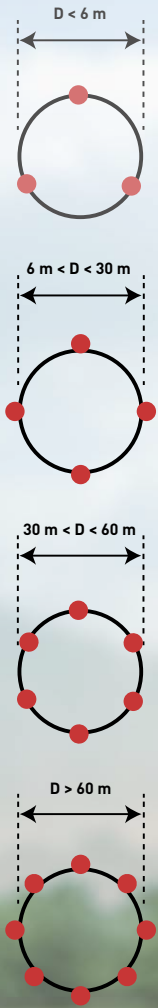

These configurations can be modified if stack are close to each other

3 LED OBSTAFASH120 red medium intensity
ICAO compliant and L-864 FAA ETL certified
below the top to avoid the smoke to hide the lights



RED AT NIGHT



DAY OFF



3 NAVILITE at mid level

RED FIXED AT NIGHT



DAY OFF

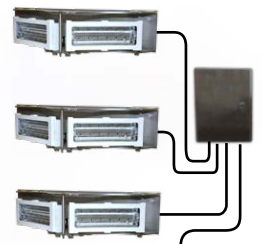

ICAO low intensity type B

Or

FAA L-810 type with NPT pipe

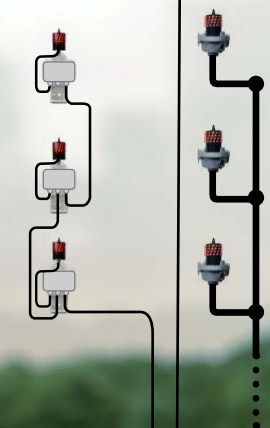

110-240 VAC power supply and Photocell at the bottom with or without batteries



Photocell north oriented



110 to 240 VAC



OBSTRUCTION LIGHTING FOR CRANE

Use case for crane with or without red and white strips.

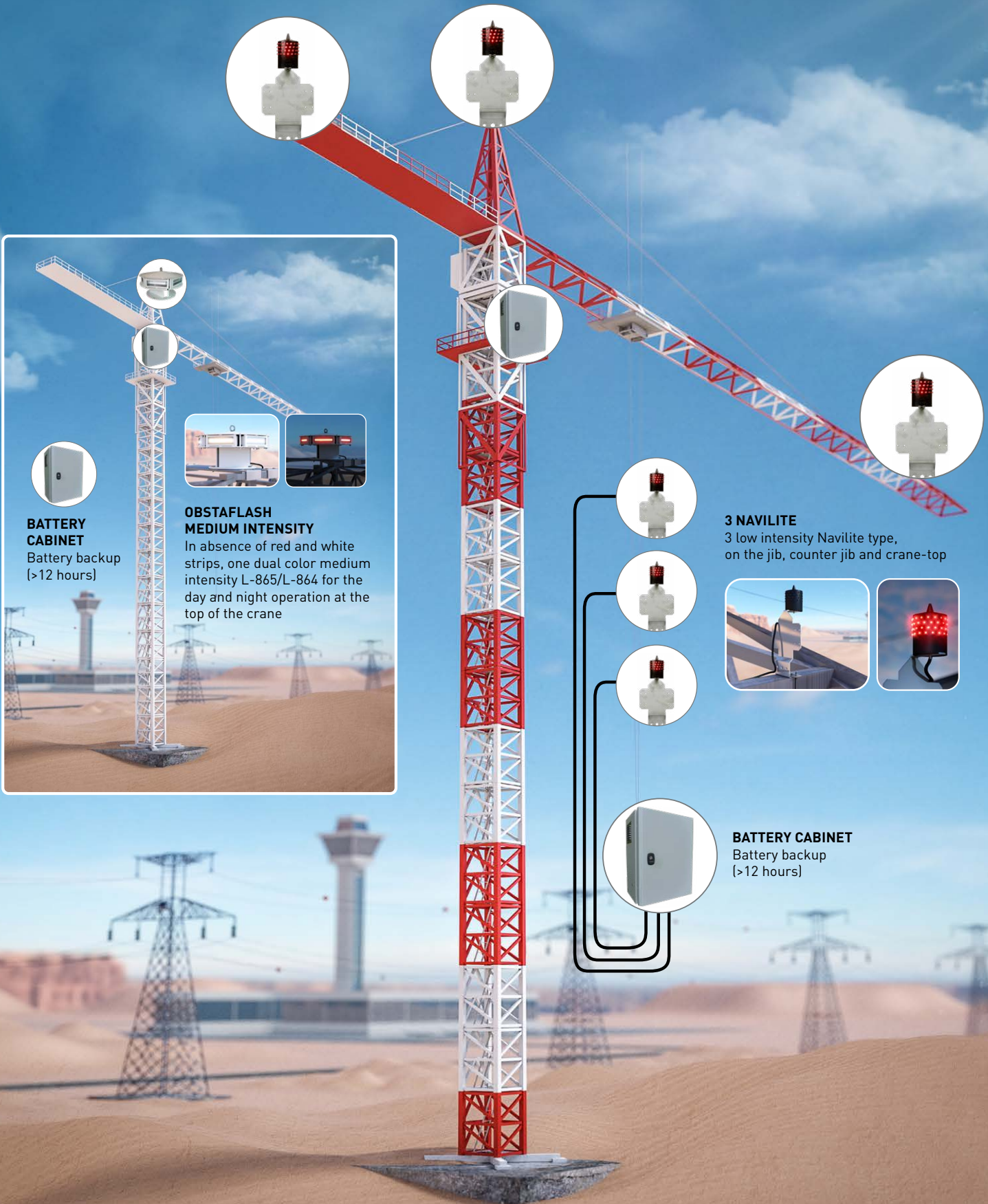

BATTERY CABINET
Battery backup (>12 hours)

OBSTAFASH MEDIUM INTENSITY
In absence of red and white strips, one dual color medium intensity L-865/L-864 for the day and night operation at the top of the crane

3 NAVILITE
3 low intensity Navilite type, on the jib, counter jib and crane-top



BATTERY CABINET
Battery backup (>12 hours)



OBSTRUCTION LIGHTING FOR WIND TURBINE

TOP LEVEL

Red compact medium intensity



Or

Dual color medium intensity

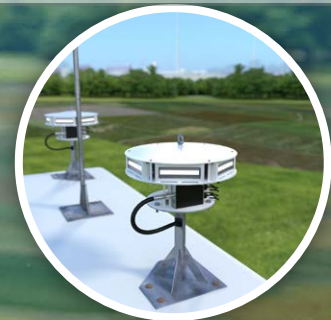

MID LEVEL

In option low intensity type E
3 Navilite





OBSTRUCTION LIGHTING FOR POWERLINE Day & night operation (Pylon >45m)

1 OFI
Medium Intensity White & Red at top level
White during daytime and red during night



- Type A & B compliant to ICAO, CAA and FAA L-865/ L-864 certified
- IP66 verified
- Easy installation with only captive parts
- 6 LED projectors in hard glass and aluminium
- 2 lights in one with 2 LED circuits in redundancy
- Surge protection included
- Optional GPS interface for synchronisation
- 50cm diameter x 30cm height - Weight: 14kg

OFC
Medium Intensity Red Only or Dual color at top level



or

- Type B & C compliant to ICAO, CAA and FAA L-864
- Self contained and compact solution
- 6 LED Optics in hard glass and aluminium cover (no plastic)
- IP66 verified
- Easy installation with only captive parts
- 2 lights in one with 2 LED circuits in redundancy
- Very low consumption : 3W @ 20 FPM (ICAO setting)
- Surge protection included
- Optional GPS interface for synchronisation
- Available with Infrared
- Dimensions: 20cmx20cmx20cm - Weight: 5 kg

2 NAVILITE (optional)
Low intensity Red at intermediate level



- Type A & B compliant to ICAO, CAA
- Very compact with one mounting screw
- 64 LED in redundancy, resin molded
- Beacon light not grounded (Class II)
- Fully waterproof (IP67)
- No corrosion
- Bird spike
- 6cm diameter x 10cm height - Weight: 370g

3 SOLAR KIT
Autonomous power supply

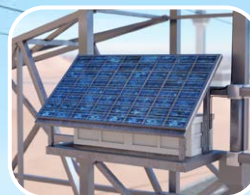

- Size calculated from localization and flash per minute
- Long life solar gel batteries
- Initial capacity with at list 6 days of autonomy
- Protection of the battery against deep discharges
- Surge protection
- Option GPS synchronization & 3G modem communication

4

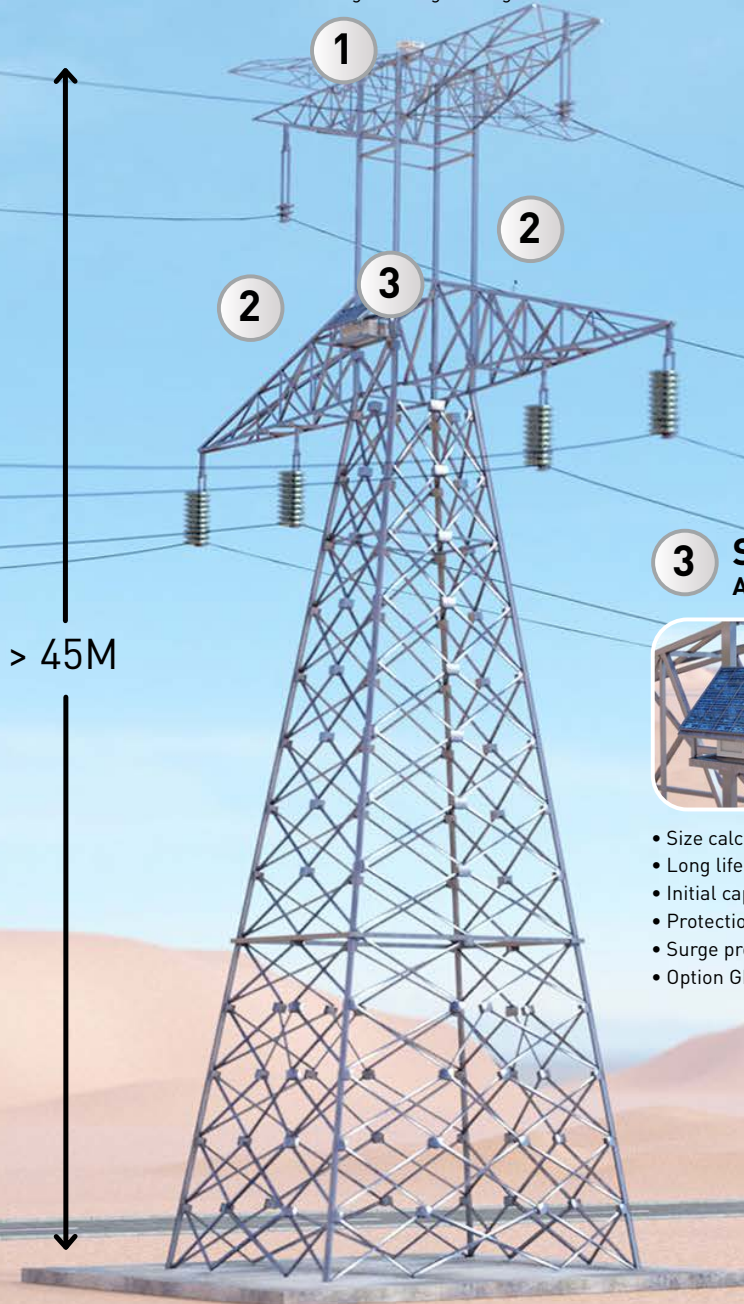

> 45M



5 PLASTIC WARNING SPHERE 600MM
Every 30M on OPGW or conductor up to 132kV



- ICAO and CAA compliant
- Polyethylene, fast mounted per half
- EPDM clamps to not damaged the cable
- No need of armor rod unless specified
- 8 drainage holes to prevent water accumulation
- Available in red, white and orange aviation

6 ALUMINIUM WARNING SPHERES 600MM
Every 30M on power cables up to 420kv and 250°C



- ICAO Compliant
- Fast mounting per half with latches
- Only 1 personne required for installation, only captive parts
- 8 drainage holes to prevent water accumulation
- Long durability in all climate conditions
- Available in white and red aviation

4 BALISOR - CONDUCTOR WARNING LIGHT

Night Time every 70M nearby airport, 105M otherwise



- Versions from 60KV to 550KV
- ICAO compliant Low Intensity Red steady-burning light
- Hard glass cold neon discharge tube
- OBSTA patented and manufactured in-house from 1938
- Self generation of energy in conductor
- No maintenance through decades
- Interference suppression included

7 BIRD-FLIGHT Diverter spiral or disk type



- Made with high impact PVC with UV protection
- Full unit or half available
- Low weight
- Quick and easy manual installation
- Positive grip on the conductor
- Long service life without deterioration
- Wind resistant
- Available in dark gray, yellow or red.



5

6

GROUND CABLE

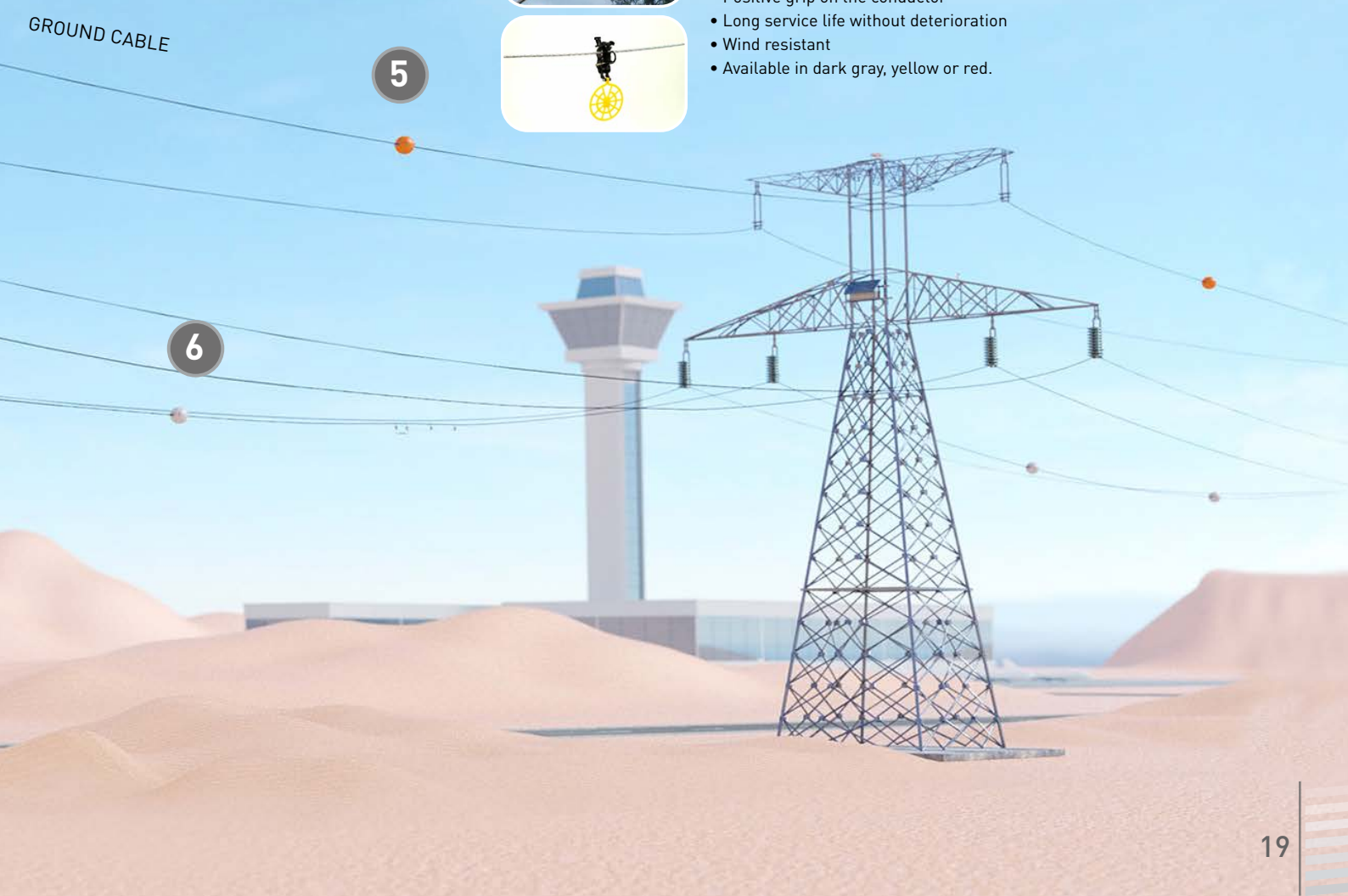



NAVILITE 12 - 24 - 48 VDC

Low intensity type A and B

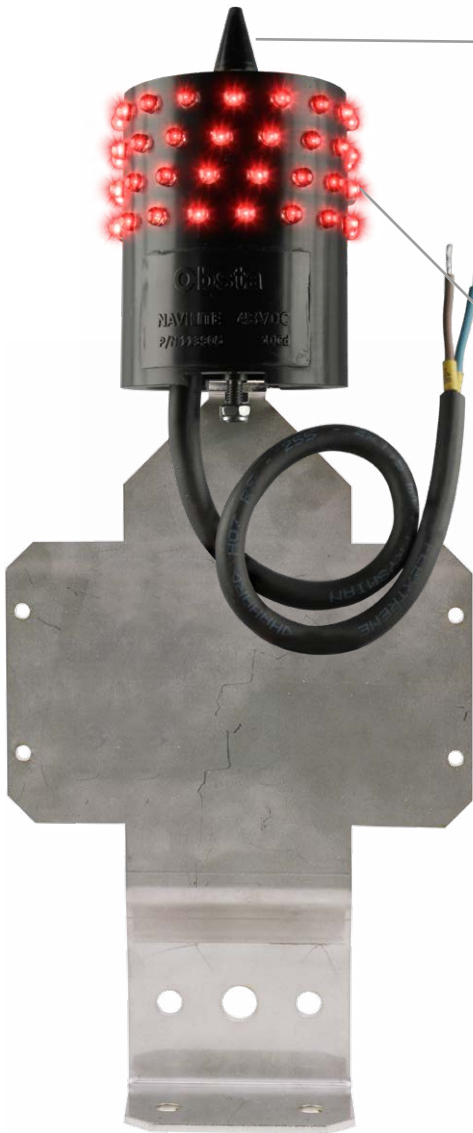

NAVILITE-48V-cable + stainless bracket



One-piece molded

- perfectly waterproof
- no corrosion risk
- lifetime 10 times higher than for incandescent lights
- no rise from the ground potential (due to lightning for example)
- bird spike

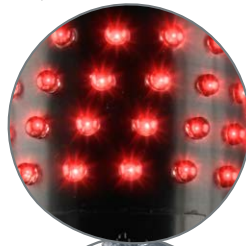

LED light

- Total of 64 diodes
- 16 circuits of 4 LEDs
- LED wiring 4 by 4 in active redundancy @ 90°
- molding provides perfect support of the LED inclination angle
- excellent heat dissipation



Wiring by pod

2 options : Pods or cable

- Continuous current 12, 24 and 48 VDC
- optional power supply through a backup power source for continuity of the marking (batteries) or through solar generator.
- Available with terminal connection or 35cm cable



Molded cable

NAVILITE - XX - XXX - cable

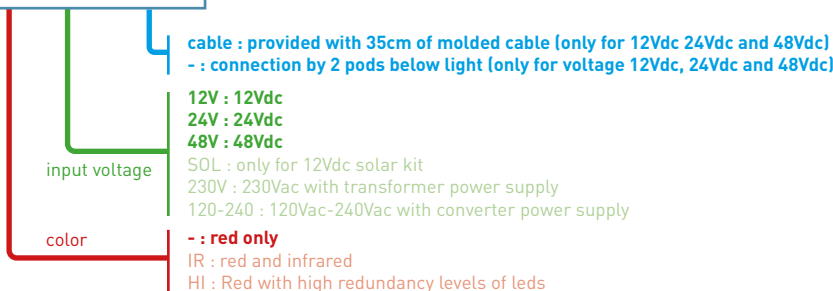



LIGHT INTENSITY DIAGRAM

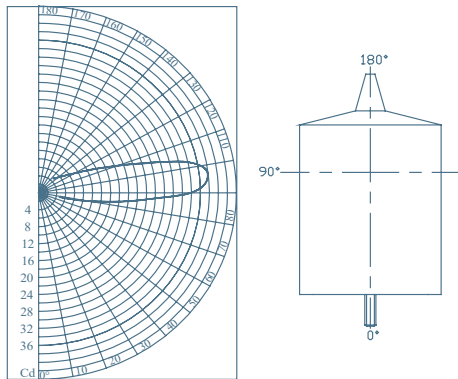

| | NAVILITE Type A and B |
|-----------------------|-------------------------|
| IP degree | 66 |
| Operating temperature | -40° + 55°C |
| Power supply | 12, 24, 48 VDC (+/-10%) |
| Light weight | 370 g |
| Attachment | M5 screw (provided) |
| Maintenance | none |

* The weight of the fixing bracket is 0.75kg

DIMENSIONS (IN MM)

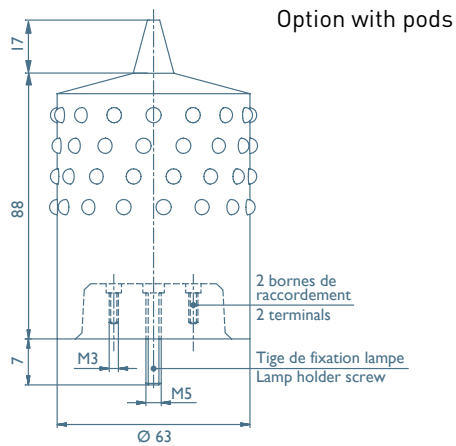

ACCESSORIES

- Stainless steel mounting bracket - P/N 113920 for Navilite & optional box.

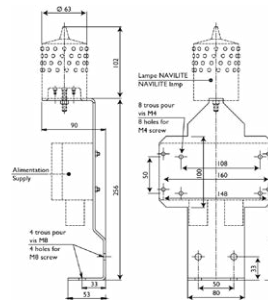

- Monitoring box for Navilite 48V (see page 30)
- Junction box (P/N 113943) (see page 30)
- Battery Cabinet with 12 hours power backup (see page 50)

MAIN REFERENCE

| | Designation | Part number | Power supply | Luminous intensity | Electrical current | Nominal power | Lifetime |
|-------|-------------------|-------------|--------------|--------------------|--------------------|---------------|----------|
| Pod | NAVILITE-48V | 113900 | 48 VDC | > 32 Cd | 125 mA | 6 W | decades |
| | NAVILITE-24V | 113901 | 24 VDC | > 32 Cd | 250 mA | 6 W | |
| | NAVILITE-12V | 113902 | 12 VDC | > 32 Cd | 500 mA | 6 W | |
| Cable | NAVILITE-48-cable | 113905 | 48 VDC | > 32 Cd | 125 mA | 6 W | |
| | NAVILITE-24-cable | 113906 | 24 VDC | > 32 Cd | 250 mA | 6 W | |

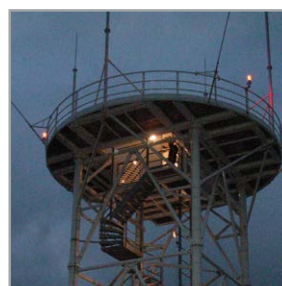



SOLAR NAVILITE 12 VDC

Low intensity type A



NAVILITE - SOL + stainless bracket

One-piece molded

- perfectly waterproof
- no corrosion risk
- lifetime 10 times higher than for incandescent lights
- no rise from the ground potential (due to lightning for example)
- bird spike

LED light

- Total of 64 diodes
- 16 circuits of 4 LEDs
- LED wiring 4 by 4 in active redundancy
- molding provides perfect support of the LED inclination angle
- excellent heat dissipation

OBSTA Solar kit

- Continuous current 12 VDC with regulation
- optional Obsta solar generator.
- Size depending on latitude and longitude.

NAVILITE - XX - XXX - cable





LIGHT INTENSITY DIAGRAM

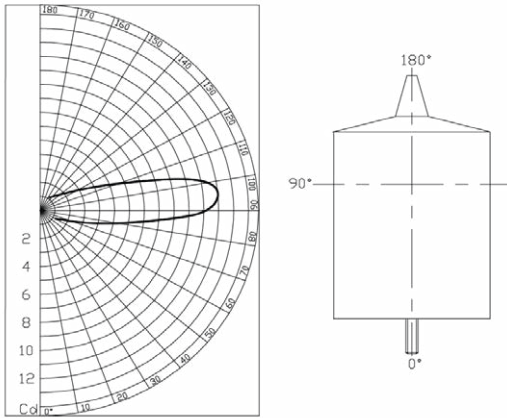

| | NAVILITE Type A |
|-----------------------|------------------------------|
| IP degree | 66 |
| Operating temperature | -40° + 55°C |
| Power supply | >12 VDC from Obsta Solar Kit |
| Light weight | 370 g |
| Attachment | M5 screw (provided) |
| Maintenance | none |

* The weight of the fixing bracket is 0.75kg

DIMENSIONS (IN MM)

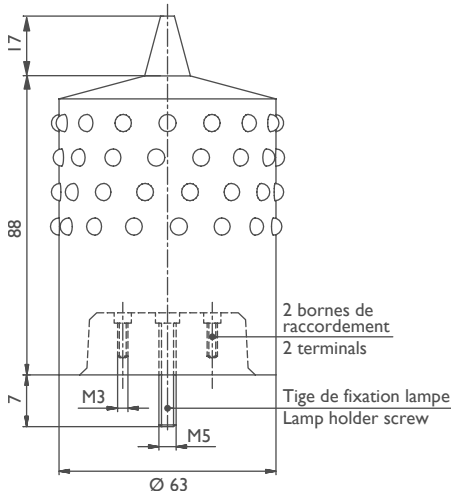

ACCESSORIES

- Stainless steel mounting bracket - ref. 113920

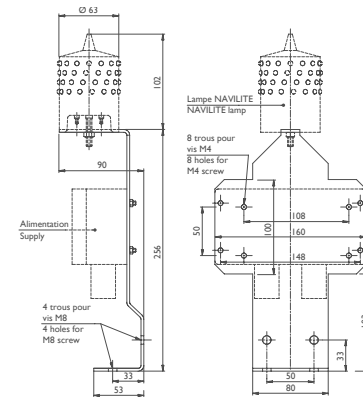

- "Main and back-up" command box P/N 113942 for 2 NAVILITE-SOL
- Solar kit P/N 1003SOL (see page 49)

MAIN REFERENCE

| Designation | Part number | Power supply | Luminous intensity | Electrical current | Nominal power | Lifetime |
|--------------|-------------|--------------|--------------------|--------------------|---------------|----------|
| NAVILITE-SOL | 113903 | 12 VDC | > 10 Cd | 250 mA | < 3 W | Decades |

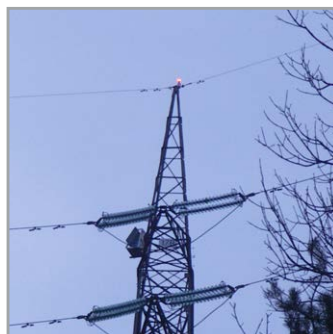



NAVILITE 110-240 VAC

Low intensity type A and B



NAVILITE-240i
P/N 113909i
+ stainless bracket P/N 113920

- for navilite-240i

- same light than Navilite-48V but with AC/DC converter and surge protection built inside



NAVILITE-230V
P/N 113909 (113905+113911)
+ stainless bracket P/N 113920

- for navilite-230V

- 230VAC power transformer providing galvanic isolation with the light (see page 31 for more information for the power supply 113911)

NAVILITE - XX - XXX - cable

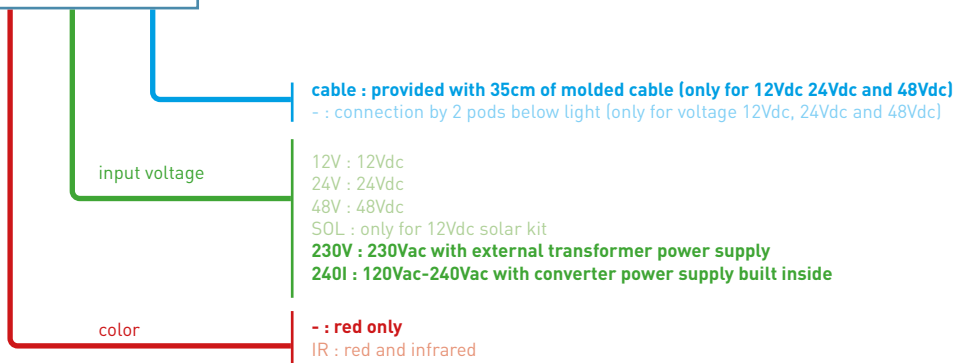



LIGHT INTENSITY DIAGRAM

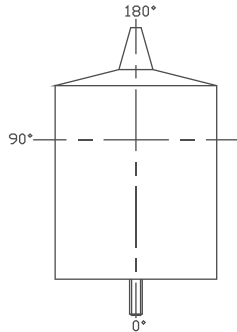
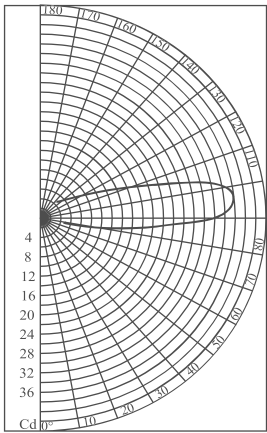

| | NAVILITE Type A and B |
|---|--|
| IP degree | 66 |
| Operating temperature | -40° to + 55°C |
| Power supply | 230 VCA (+/-10 %) = 113909 110 à 240 V (+/-10%) = 113909I |
| Weight (light) (excluding fixing bracket*) | 370 g = 113909 950 g = 113909I |
| Attachment | by screw M5 (provided) |
| Maintenance | none |

* The weight of the fixing bracket is 0.75kg

DIMENSIONS (IN MM)

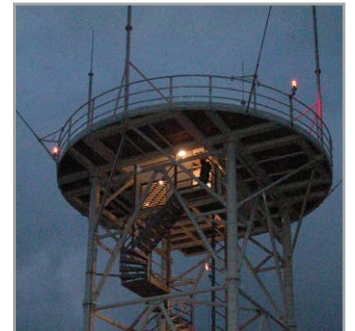
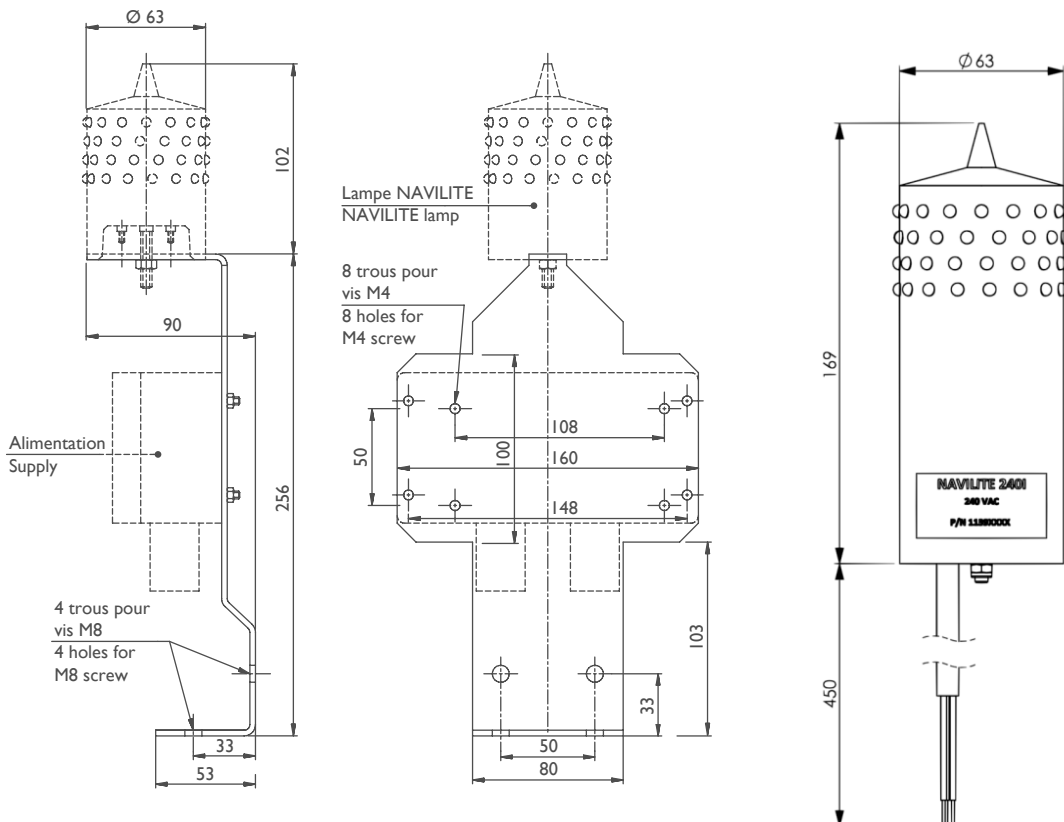

ACCESSORIES

- Stainless steel mounting bracket ref. 113920

MAIN REFERENCE

| Designation | Part number | Power supply | Luminous intensity | Electrical current | Nominal power | Lifetime |
|---------------|-------------|--------------|--------------------|--------------------|---------------|----------|
| NAVILITE-230V | 113909 | 230 VAC | > 32 Cd | 70 mA | 6 W | decades |
| NAVILITE-240I | 113909I | 120-240 VAC | > 32 Cd | 70 mA | 6 W | |



NAVILITE IR

Led low intensity type A and B + infrared



Night Vision Goggles compatible according to OFAC directive (Switzerland)

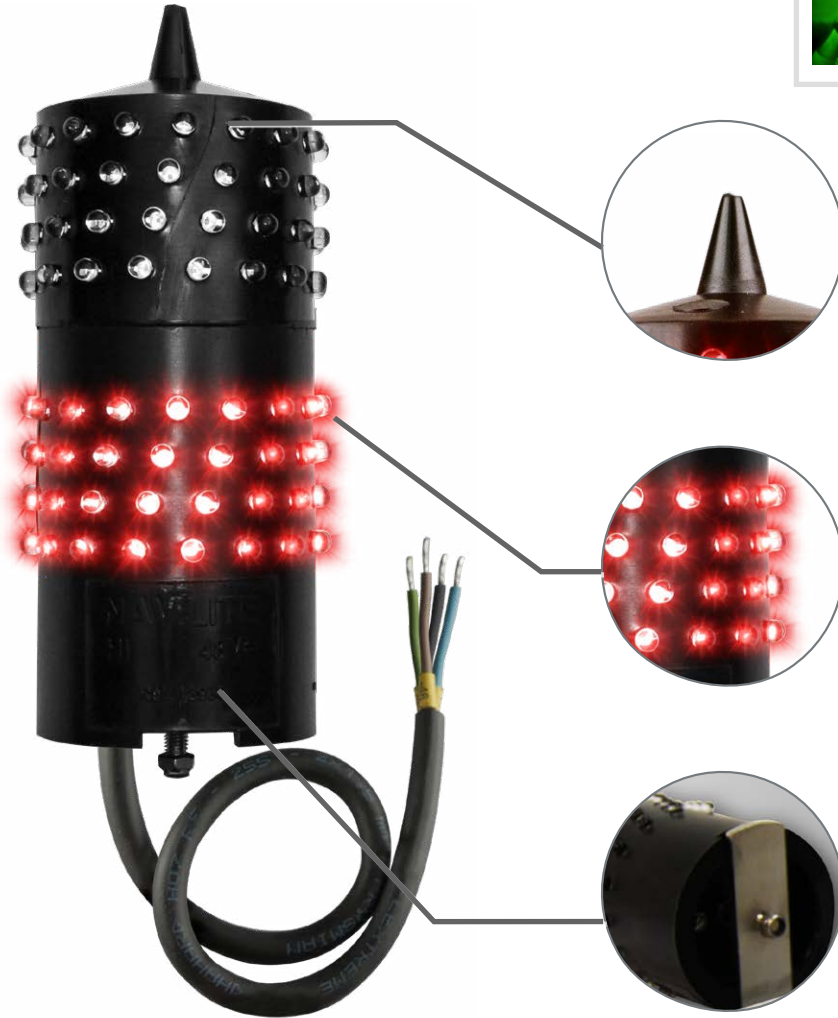

One-piece molded

- perfectly waterproof
- no corrosion risk
- no rise from the ground potential (due to lightning for example)
- bird spike

LED light

- Total 64 red diodes + 64 infrared diodes
- 2x 16 circuits of 4 LEDs
- LED wiring 4 by 4 in active redundancy @ 90°
- molding provides perfect support of the LED inclination angle
- 2 independent circuits for red and infrared

Power supply

- Continuous current 12, 24 and 48 VDC
- optional 230VAC command box for infrared leds blinking mode.

NAVILITE-48V-cable

NAVILITE - XX - XXX - cable





LIGHT INTENSITY DIAGRAM

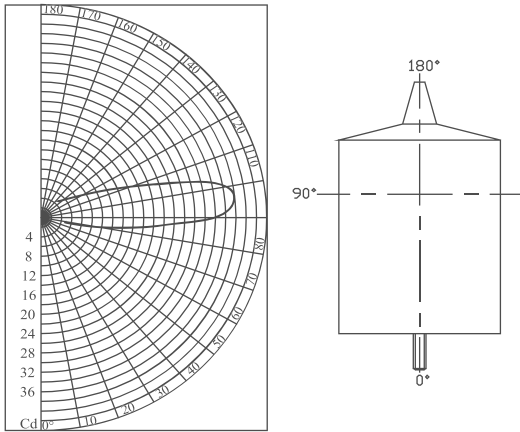

| | NAVILITE Type A and B |
|-----------------------|------------------------------------|
| IP degree | 66 |
| Operating temperature | -40° + 55°C |
| Power supply | 12, 24, 48 VDC (+/-10%) |
| Light weight | 0.92kg (excluding fixing bracket*) |
| Attachment | by screw M5 (provided) |
| Maintenance | none |

* The weight of the fixing bracket is 0.75kg

DIMENSIONS (IN MM)

113905IR+113925+113943-AL

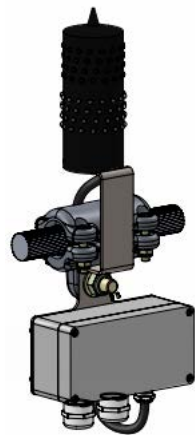
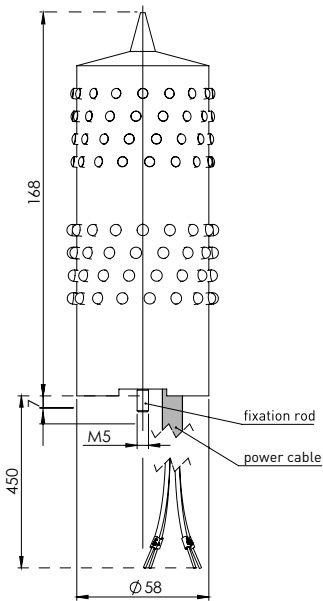

ACCESSORIES

- Stainless bracket part number 113920
- Stainless bracket for ground cable part number 113925
- Optional accessories
- junction box part number 113943-AL
- 100-240Vac command box part number 113912 for infrared blinking mode
- 48Vdc command box part number 113915 for infrared blinking mode



MAIN REFERENCE

| | Designation | part number | Power supply | Luminous intensity | IR intensity and wavelength | Nominal power | Lifetime |
|--------------|------------------------------|-----------------|--------------|--------------------|-----------------------------|---------------|----------|
| cable | NAVILITE-IR-48V-cable | 113905IR | 48 VDC | > 32 Cd | 150mW/sr @ 850nm | < 12 W | decades |



NAVILITE FAA L810

FAA L-810 compliant with ICAO low intensity type B

L-810(L) as per FAA 150-5343H



NAVILITE-FAA-100-240Vac

One-piece molded

- Light perfectly waterproof
- no corrosion risk
- no losing parts
- bird spike
- 2 x 1" NPT threaded holes

LED light

- Total of 64 diodes
- 16 circuits of 4 LEDs
- LED wiring 4 by 4 in active redundancy at 90°
- provide perfect support of the LED inclination angle
- excellent heat dissipation

Power supply

- Modular design with separate power supply in aluminium housing mounted
- 48 VDC or 110 VAC to 240 VAC power supply
- Surge protection included
- Alarm relay included
- 2 x 3/4" NPT threaded holes for mounting (or with stainless bracket P/N113928 and standard cable entry in absence of FAA rigid conduit)



LIGHT INTENSITY DIAGRAM

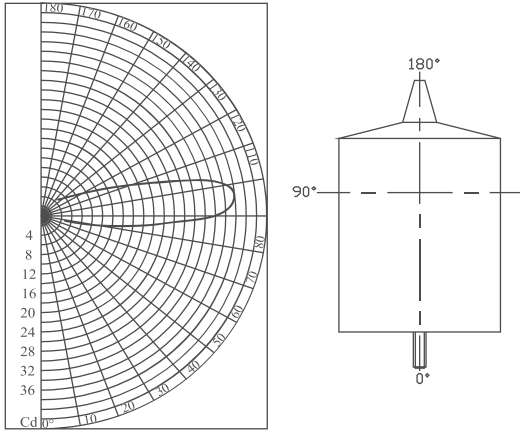

| | NAVILITE L-810 |
|-----------------------|---|
| IP degree | 65 in vertical position |
| Operating temperature | -40° to + 55°C |
| Power supply | 110 VAC to 240VAC and 48VDC (+/- 10%) |
| Weight (light) | 370 g (excluding aluminium base) |
| Weight (light + base) | 1.4 kg (fixed through vertical or horizontal NPT) |

DIMENSIONS (IN MM)

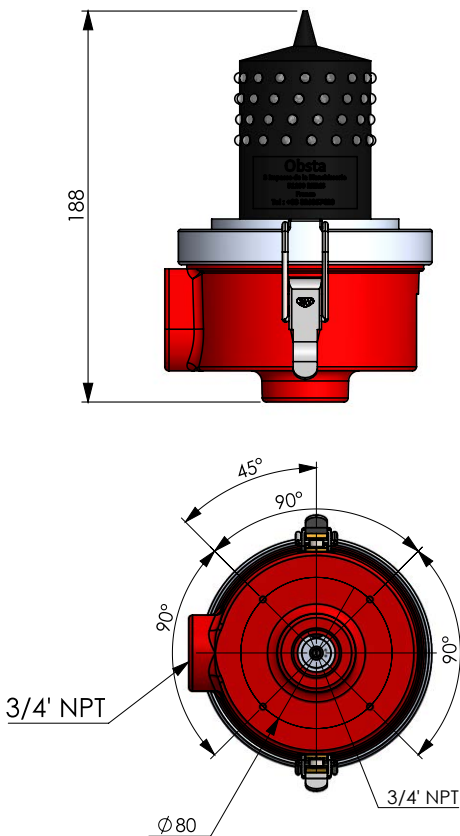

ACCESSORIES

- Support for horizontal or vertical attachment P/N 113928
- 100-240Vac command box part number 113942 for NAVILITE 48Vdc P/N 113965.

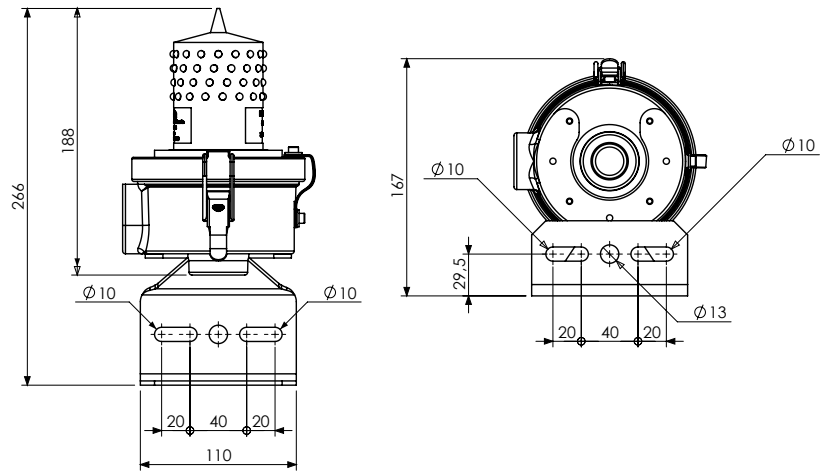

With bracket P/N113928

MAIN REFERENCE

| Designation | Part number | Power supply | Luminous intensity | Nominal power | Theoretical lifetime |
|-----------------------|-------------|--------------------|----------------------|---------------|----------------------|
| NAVILITE-FAA-100-240V | 113969 | 110 VAC to 240 VAC | As per FAA 150-5343H | 6 W | decades |
| NAVILITE-FAA-48V | 113965 | 48 VDC | | 6 W | decades |



NAVILITE FAA L810 IR

FAA L-810 compliant with ICAO low intensity type B

L-810(L) as per FAA 150-5343J ETL certified



One-piece molded

- Light perfectly waterproof
- no corrosion risk
- no losing parts
- bird spike
- 2 x 1" NPT threaded holes

LED light

- Total of 128 diodes
- 16 circuits of 4 LEDs with Infrared
- LED wiring 4 by 4 in active redundancy at 90°
- provide perfect support of the LED inclination angle
- excellent heat dissipation

Power supply

- Modular design with separate power supply in aluminium housing mounted
- 110 VAC to 240 VAC power supply
- Surge protection included
- Alarm relay included
- Mimic with L-864 medium intensity (flashing mode) or fixed mode
- 2 x ¾" NPT threaded holes for mounting (or with stainless bracket P/N113928 and standard cable entry in absence of FAA rigid conduit)

NAVILITE-IR-FAA-120-240V



Night Vision Goggles according to FAA 150-5343J



LIGHT INTENSITY DIAGRAM

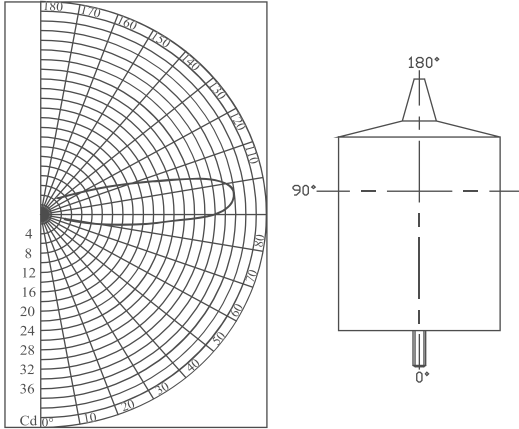

| | NAVILITE L-810 |
|-----------------------|--|
| IP degree | 65 in vertical position |
| Operating temperature | -40° to + 55°C |
| Power supply | 110 VAC to 240VAC 48Vdc +/- 10% |
| Weight (light + base) | 1.4 kg (fixed through vertical or horizontal NPT) |

DIMENSIONS (IN MM)

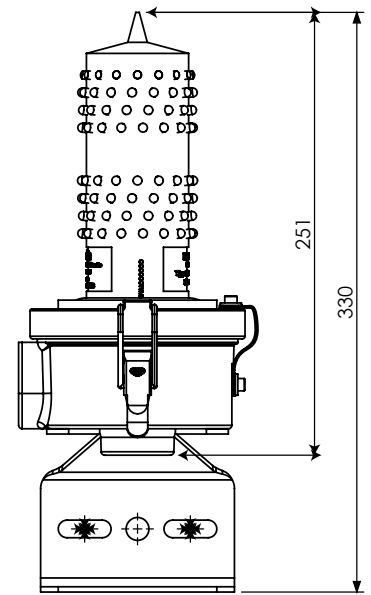
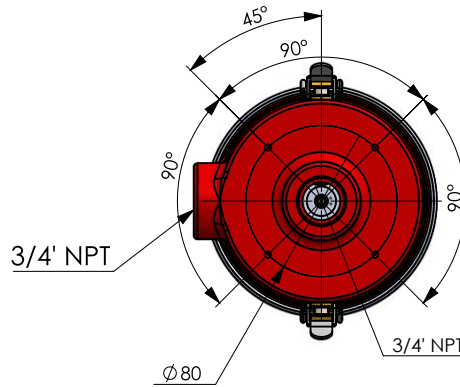
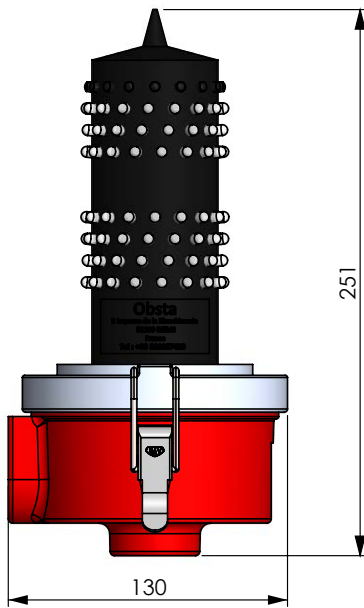

With bracket P/N 113928

ACCESSORIES

- Support for horizontal or vertical attachment P/N 113928

MAIN REFERENCE

| Designation | Part number | Power supply | Luminous intensity | Nominal power | Theoretical lifetime |
|--------------------------|-------------|--------------------|----------------------|---------------------|----------------------|
| NAVILITE-IR-FAA-100-240V | 113969IR | 110 VAC to 240 VAC | As per FAA 150-5343J | 8 W (fixed mode) | decades |
| NAVILITE-IR-FAA-048 | 113965IR* | 48 VDC | As per FAA 150-5343J | 8 W (fixed mode) | decades |

* not ETL listed



ACCESSOIRES FOR NAVILITE

Monitoring and control boxes offered with the NAVILITE are designed for an easy use and installation follow up on the complete obstruction lights system.

JUNCTION BOX FOR NAVILITE, OBSTA HI/STI AND OFC



Main characteristics

- Polycarbonate box
- Junction box for 1 or 2 NAVILITE to power cable
- Suitable for all voltage
- 4 cable entries
- Terminals connections for the wires

References

| Designation | part number | voltage | Number of cable entries | Cable cross section |
|-------------|-------------|---------|-------------------------|---------------------|
| NAV-JB-4 | 113946 | all | 4 | 2.5 mm ² |
| NAV-JB-3-AL | 113943-AL | all | 3 | 4 mm ² |

Typical configuration with Navilite-48V

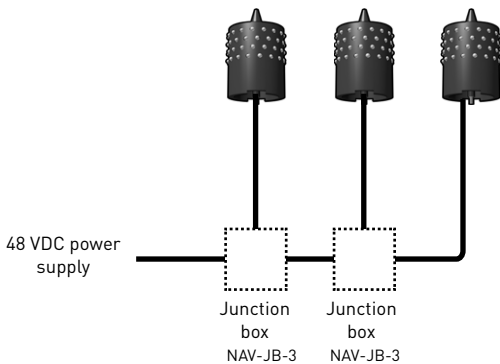

230 V POWER SUPPLY FOR NAVILITE 48 VDC



Main characteristics

- 230VAC power transformer providing galvanic isolation with the light
- 3 cable entries
- Up to 4 NAVILITE-48VDC can be connected to the power supply

Reference

| Designation | part number | input voltage | Number of lights | main and back-up | simultaneously | alarm | remote alarm |
|----------------|-------------|---------------|------------------|------------------|----------------|-------|--------------|
| 48V-NAV-PW-240 | 113911 | 230VAC | 1-4 Navilite-48V | no | yes | no | no |



COMMAND BOX FOR NAVILITE 48 VDC AND NAVILITE-SOL



Main characteristics

- Polycarbonate box with or without transparent cover
- Redundancy wiring (one main light and one backup light)
- Integrated photocell
- Alarm monitoring in case of lights or power supply failure
- Switch from main light to backup one in case of failure
- Blinking mode (Low intensity type E, L-810(F), Navilite-RI-48V)
- Configuration done by dip-switches

Command box for navilite 48 Vdc

| Designation | part number | input voltage | Number of lights | main and back-up or simultaneous | Photocell | Surge protection | remote alarm | Mimic with Red medium intensity |
|---------------------|-------------|---------------|------------------|----------------------------------|-----------|------------------|--------------|---------------------------------|
| 48V-NAV-CMD-100/240 | 113912 | 100-240VAC | 1-4 Navilite-48V | yes | yes | yes | yes | yes |
| NAV-CMD-48-B | 113915 | 48VDC | 1-4 Navilite-48V | yes | yes | yes | yes | yes |

Typical configuration with 2 Navilite-48V

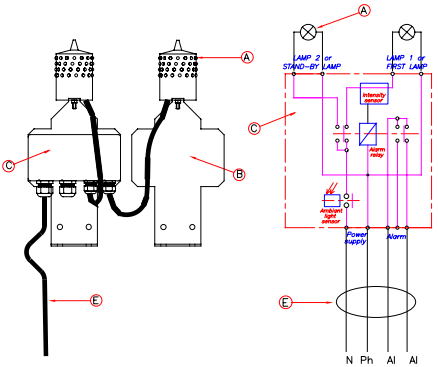

Alarm conditions :

- Low intensity of the lamp(s)
- Short-circuit of the lamp(s)
- Power supply failure

Nomenclature / Bill of materials

| Reference | Quantity | Part number | Designation |
|-----------|----------|------------------|----------------------|
| A | 2 | 113905 | Navilite 48VDC |
| B | 2 | 113920 | Navilite bracket |
| C | 1 | 113912 or 113915 | Command box |
| E | - | 113160 | 5G1.5 flexible cable |

Cable must be shielded when used in electro-magnetic fields

Other configurations

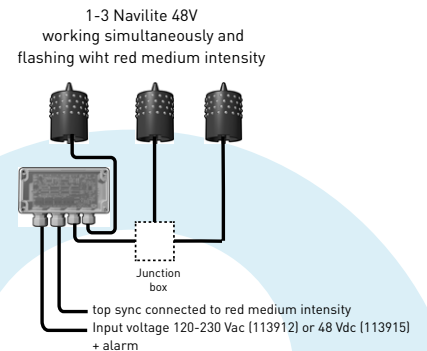
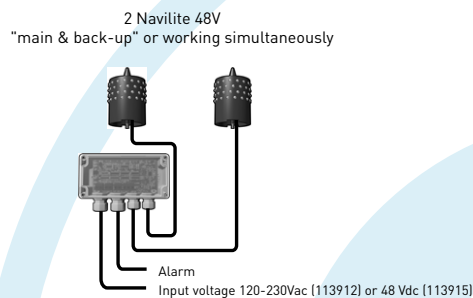
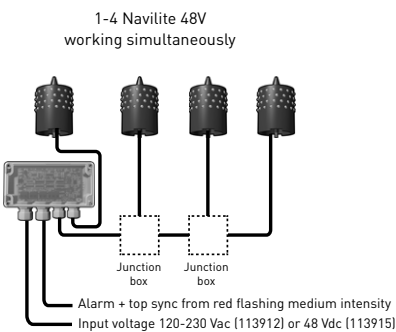

WEIGHT & DIMENSIONS (FOR ALL MODEL)

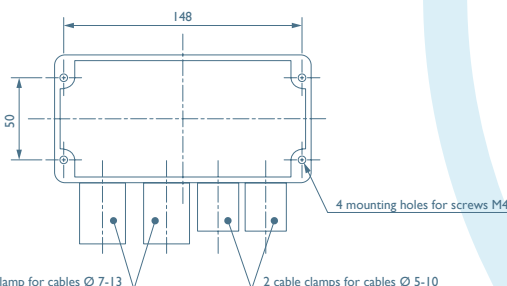

| | |
|----------------------------------|-------------------------------|
| IP degree (in vertical position) | 65 |
| Power Cable diameter | from 7 to 13 mm |
| Wire cross section | from 1 to 2.5 mm ² |
| Attachment | 4 screws type M4 |



OBSTA HISTI 110 to 240 VAC

The OBSTA HI STI is devoted to the marking of all kinds of obstacles such as buildings, airports, broadband towers, high voltage power poles. One model allow can cover every voltage from 110VAC up to 240VAC.

L-810 FAA 150-5343G

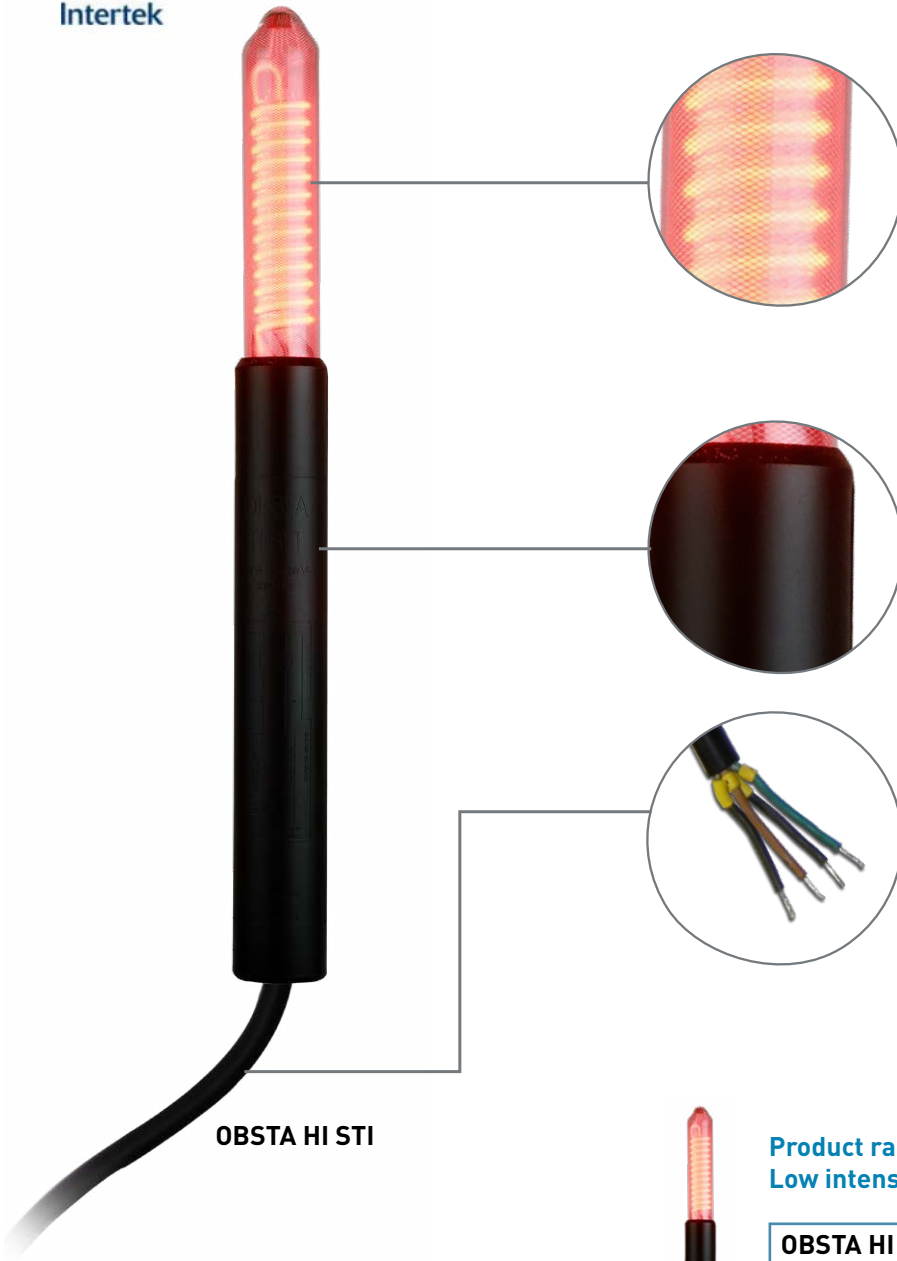

OBSTA HI STI

Neon light

- 13 turns
- hard glass cover and tube
- «aviation» red color
- very long life expectancy in all climatic environment
- great light efficiency
- luminosity substantially higher than what is recommended by ICAO and FAA
- low power consumption

One-piece molded

- perfectly waterproof
- no grounding issue
- all wiring configuration available
- no rise from the ground potential (due to lightning for example)
- increased reliability

Power cable

- 110 VAC up to 240 VAC
- protected against transient overvoltages
- alarm relay in case of lamp failure or low power

Product range HI STI Low intensity cold neon discharge 32CD

OBSTA HI STI - F - APR

- : class II
- APR : class I (only 110 up to 240VAC)
- 240V : 110 up to 240VAC
- F 24V: 24Vdc



LIGHT INTENSITY DIAGRAM

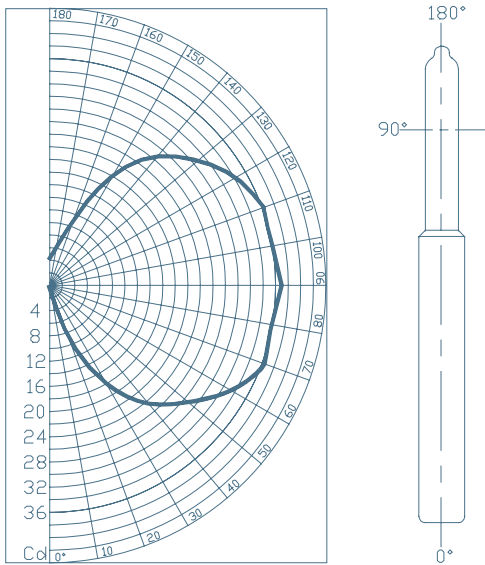

| | HISTI |
|-----------------------|---|
| IP degree | 66 |
| Operating temperature | -30° + 60°C |
| Power supply voltage | from 110 up to 240V (+/-10%) 50/60 Hz |
| Weight | 2.3 kg |
| Attachment | 2 screws type M8 (provided) Thickness to screw into : 1 up to 5 mm |
| Wiring | On stripped wires (2 power wires, 2 alarm wires) |

DIMENSIONS (IN MM)

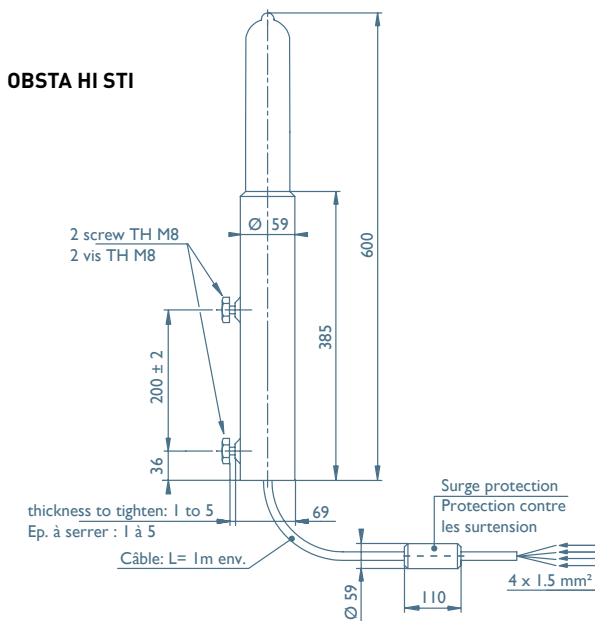

SPECIAL PRECAUTIONS

For chimney installation, install the light under the top (1.5 to 3m, 5 to 10ft), as per ICAO and FAA recommendations.
For installation in intense electromagnetic fields, the use of shielded wire is highly recommended.

OTHER FUNCTIONS

- Failure remote signalization by relay (see diagram)
- «Active redundancy» configuration allows the automatic turn on of a backup light and/or of an alarm in case of failure of the main light (see diagram)
- Photocell controlled
- Light shielded as per standard EN 55011, class B
- **Stainless steel mounting bracket** (ref. 113121 for one light and 113124 for two lights)
- **Connection accessories** (see page 36)

MAIN REFERENCE

| Designation | OBSTA part number | Power supply | Luminous intensity | Current consumption | Nominal power | Theoretical lifetime (without any light decrease*) |
|-------------------------|-------------------|---|--------------------|---------------------------------|---------------|--|
| OBSTA HI STI | 113110 | from 110 V eff. up to 240 V 50/60 Hz | > 32 Cd | 110V - 730 mA 240 V - 370 mA | 45 W | 10 years |
| OBSTA HI STI-APR | 113113 | from 110 V eff. up to 240 V 50/60 Hz | > 32 Cd | 110V - 730 mA 240 V - 370 mA | 45 W | 10 years |

* with power supply stabilized

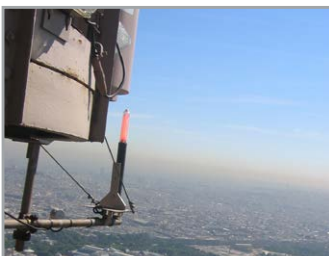



OBSTAFLASH COMPACT OFC

L-864 FAA (AC 150/5345-43J) certified
ICAO Red Medium intensity type B & C / CAA compliant (fixed mode)



Characteristics

- Hard glass cover (no plastic) and aluminum based
- Easy installation with only captive parts
- 2 LED circuits in redundancy
- Adjustable flash 20 to 60 flashes per minutes (ICAO MI type B) or steady (CAA, ICAO MI type C)
- Alarm in case of light or power failure
- Low consumption
- Surge protection included
- "Night Vision compatible" in option as per Swiss directive and FAA regulation
- Photocell and GPS built-in in option

Product range OBSTAFLASH COMPACT OFC ICAO Red Medium intensity type B & C / L-864 / CAA / STAC

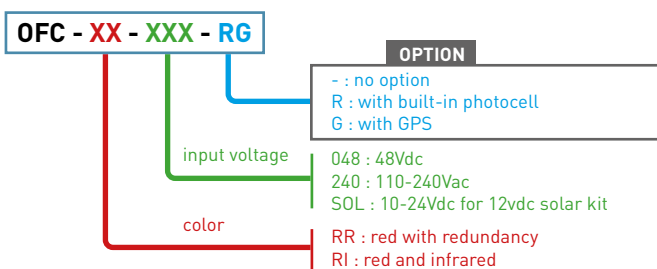



WEIGHT & DIMENSIONS (IN MM)

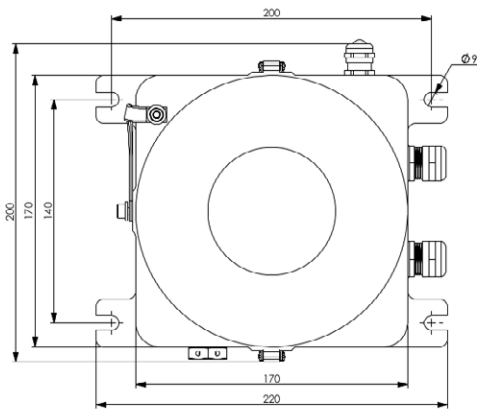
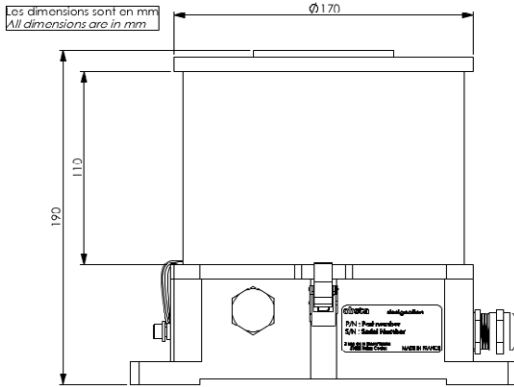

| | OFC |
|-----------------------------|-----------------------|
| IP degree | 66 |
| Operating temperature | -40°C to +55°C |
| Cable entries | 2 nickel-plated brass |
| NVG compatible for OFC-RI | |
| IR intensity and wavelength | 600mW/sr @ 800-900nm |
| Weight | 5kg |

ACCESSORIES

- Built in GPS for wireless synchronisation
- Built in Photocell for night only operation
- Optional wiring accessories
- junction box part number 113943-AL
- monitoring box for OFC & Navilite

MAIN REFERENCE FOR OFC-RR-XXX

| designation | part number | Voltage | Color | Luminous intensity | Flashes per minute | Average power consumption |
|-------------|--------------|------------|-------|--------------------|--|---------------------------|
| OFC-RR-048 | 113790RR-048 | 48Vdc | red | 2000cd RMS | As per FAA/ICAO or fixed mode (MI type C, CAA) | 6W |
| OFC-RR-240 | 113790RR-240 | 100-240Vac | red | | 6W | |
| OFC-RR-SOL | 113790RR-SOL | 12-24Vdc | red | | As per ICAO | 3W @ 20fl/minute |

MAIN REFERENCE FOR OFC-RI-XXX

| designation | part number | Voltage | Color | IR intensity and wavelength | Luminous intensity | Flashes per minute | Average power consumption |
|-------------|--------------|------------|-------|-----------------------------|--------------------|--------------------|---------------------------|
| OFC-RI-048 | 113790RI-048 | 48Vdc | red | 600mW/sr @ 800-900nm | 2000cd RMS | As per FAA | < 10 W |
| OFC-RI-240 | 113790RI-240 | 100-240Vac | red | | | | < 10 W |

- option "-G" to be added for built-in GPS for day/night and/or flash synchronisation
- option "-R" to be added for built-in photocensor



OBSTAFLASH OFI360

L-865/864 FAA (AC 150/5345-43J) Certified
ICAO white & red Medium intensity type A+B & C / CAA compliant (fixed mode)



Flashhead with integrated 48VDC power supply
Patent : EP 1966535B1 & US 7816843

Dual color Flashhead

- 6 led replaceable projectors
- Aluminium and glass envelope
- Modular design
- Easy maintenance
- Precise optic , low led current for optimal lifetime
- Integrated 48 VDC power supply inside the flashhead
- Luminous indicator for each led circuits
- Captive parts
- 48 Vdc surge protection included
- Test button and luminous indicators
- SNMP capability through additional controller

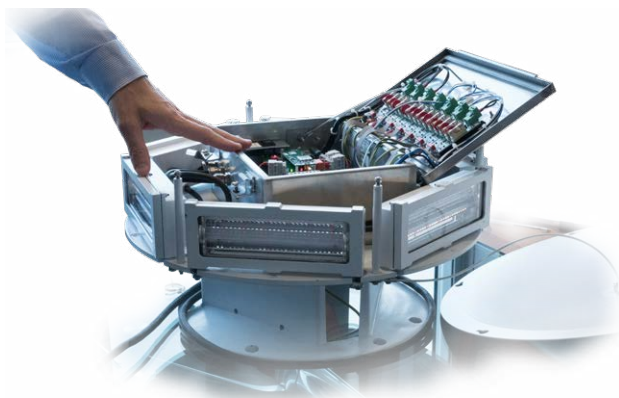

Product range OBSTAFLASH OFI360

Obstaflash Medium intensity with 48Vdc integrated power supply
ICAO White and Red Medium Intensity type A and B & C / CAA /STAC

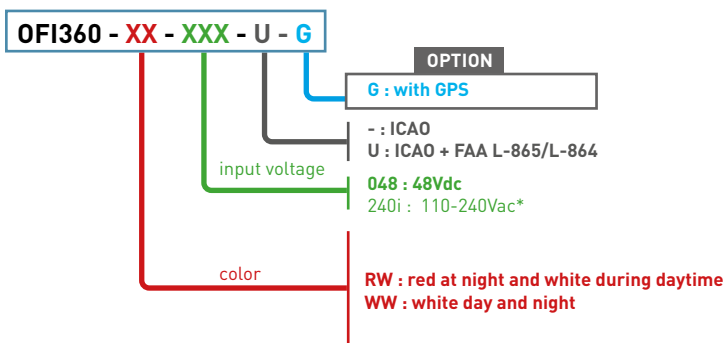



WEIGHT & DIMENSIONS (IN MM)

Flashhead

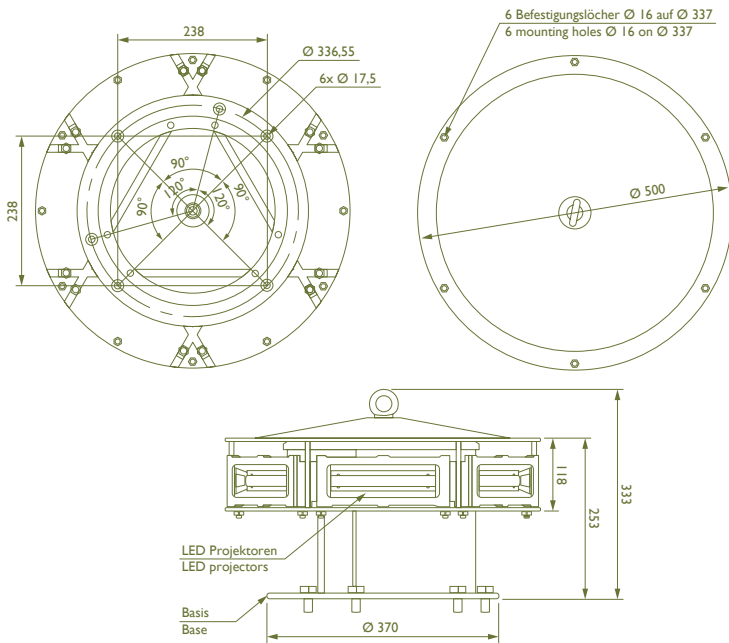

| | |
|--|-------------------------|
| IP degree for power cabinet | 65 in vertical position |
| Operating temperature | -30° to +55°C |
| Input voltage | 48 Vdc +/- 10% |
| Cable entry for flashhead, power supply, photocell and alarm | 1 nickel plated brass |

ACCESSORIES

- GPS inside flashhead part number 1137461 for wireless synchronization
- 48vdc photocell part number 100755
- 48Vdc battery cabinet (input voltage 100-240VAC) for 12 hours back-up part number 113956 (see page 50) or with stainless enclosure part number 113509

MAIN CHARACTERISTICS

| Main characteristics | Effective Luminous output on site at 0° | | Color | | Beam Spread | | Flashes per minute |
|-------------------------------|---|----------------|-----------|--------------|-------------|------------|--------------------|
| | Day | Night | Day | Night | Vertical | Horizontal | |
| Red only (L864) | light off | 2000 Cd | light off | Red | > 3° | 360° | As per ICAO or FAA |
| White only (L865) | 20 000 Cd | 2000 Cd or off | White | White or off | | | |
| Dual color (L865/L864) | 20 000 Cd | 2000 Cd | White | Red | | | |

MAIN REFERENCE

| Designation | part number | input voltage | ICAO category | FAA category | Color |
|------------------------|--------------|---------------|-------------------------------------|--------------|------------|
| OFI360-RW-048-U | 113792U | 48Vdc | Medium intensity type A & B | L-865/L-864 | dual color |
| OFI360-WW-048-U | 113791U | | Medium intensity type A | L-865 | white |
| OFI360-RW-048 | 113792 | | Medium intensity type A & B or C | - | dual color |
| OFI360-WW-048 | 113791 | | Medium intensity type A | - | white |
| OFI360-R-048-U | 113790 | | Medium intensity type B (or C, CAA) | L-864 | red |
| OFI240-RW-240-G | 113792-240-G | 110-240VAC | Medium intensity type A and B/C | - | dual color |

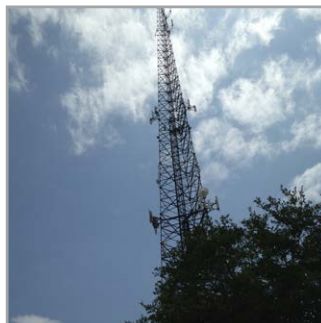



KIT OBSTAFLASH OFI360 110-240 Vac

L-865/864 FAA (AC 150/5345-43J) Certified
ICAO white & red Medium intensity type A+B & C / CAA compliant (fixed mode)



Flashhead with integrated 48VDC power supply
Patent : EP 1966535B1 & US 7816843

Flashhead

- 6 led replaceable projectors
- Aluminium and glass envelope
- Modular design
- Easy maintenance
- Precise optic , low led current for optimal lifetime
- Integrated 48 VDC power supply inside the flashhead
- Luminous indicator for each led circuits
- Captive parts
- 48 Vdc surge protection included
- Test button and luminous indicators



120-230 VAC Power cabinet

- Available in 120 /230 Vac
- Surge protection
- Automatic day/night switch with photocell
- Test button for day and night
- Modular design
- Two side lights in option, low intensity type
- Alarm contact
- Master/slave configuration for multiple lights synchronization
- SNMP ready

Product range OBSTAFLASH OFI360

Obstaflash Medium intensity with 48Vdc integrated power supply

ICAO White and Red Medium Intensity type A and B & C / CAA /STAC

OFI360 - XX - XXX - U

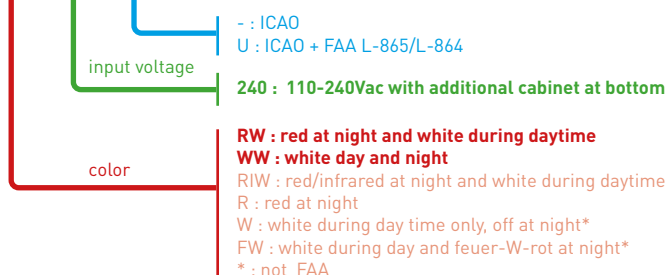



WEIGHT & DIMENSIONS (IN MM)

Flashhead

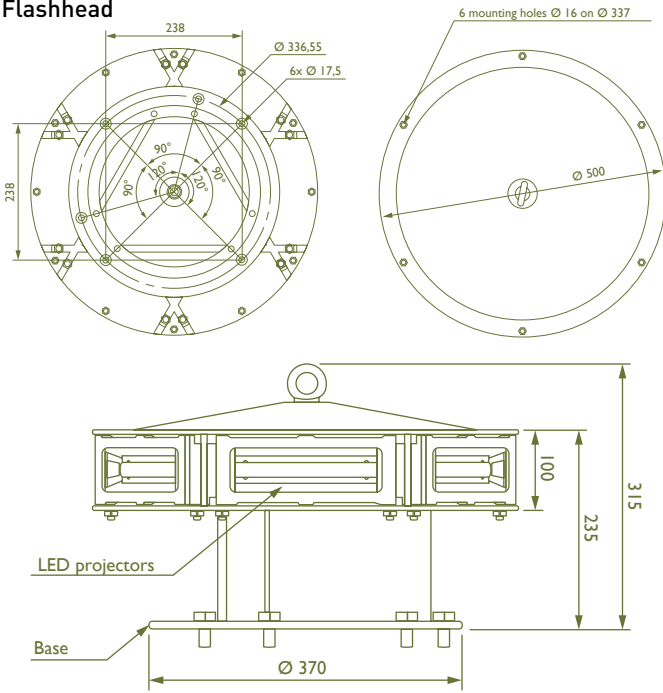

Weight: 14 kg - IP degree IP66

Control cabinet

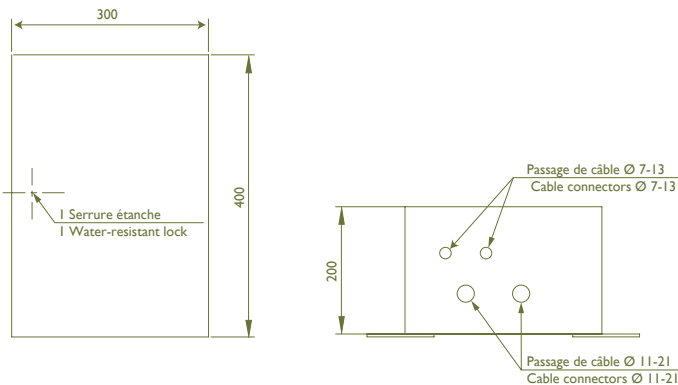

SETS COMPOSITION

| | |
|--|--|
| IP degree for power cabinet | 65 in vertical position |
| Operating temperature | -30° to +55°C |
| Input voltage | 110 VAC to 240 VAC +/-10% 50 to 60 Hz |
| Cable entry for flashhead, power supply, photocell and alarm | 4 nickel plated brass |

ACCESSORIES

- GPS module for wireless synchronization in case it is not possible to connect the lights by wires part number 113746, see page 55
- Photocell part number 100755, see page 51



MAIN CHARACTERISTICS

| Main characteristics | Effective Luminous output on site at 0° | | Color | | Beam Spread | | Flashes per minute |
|-------------------------------|---|----------------|-----------|--------------|-------------|------------|--------------------|
| | Day | Night | Day | Night | Vertical | Horizontal | |
| Red only (L864) | light off | 2000 Cd | light off | Red | > 3° | 360° | As per ICAO or FAA |
| White only (L865) | 20 000 Cd | 2000 Cd or off | White | White or off | | | |
| Dual color (L865/L864) | 20 000 Cd | 2000 Cd | White | Red | | | |

MAIN REFERENCE

| Designation | part number | input voltage | ICAO category | FAA category | Color |
|------------------------|-------------|---------------|-------------------------------------|--------------|------------|
| OFI360-RW-240-U | 113725UI | 110-240Vdc | Medium intensity type A & B | L-865/L-864 | dual color |
| OFI360-WW-240-U | 113723UI | | Medium intensity type A | L-865 | white |
| OFI360-RW-240 | 113725I | | Medium intensity type A & B or C | - | dual color |
| OFI360-WW-240 | 113723I | | Medium intensity type A | - | white |
| OFI360-R-240-U | 113724I | | Medium intensity type B (or C, CAA) | L-864 | red |

"U" for US only



KIT OBSTAFLASH OFI120

L-865/864 FAA (AC 150/5345-43J) Certified
ICAO white & red Medium intensity type A+B & C / CAA compliant (fixed mode)

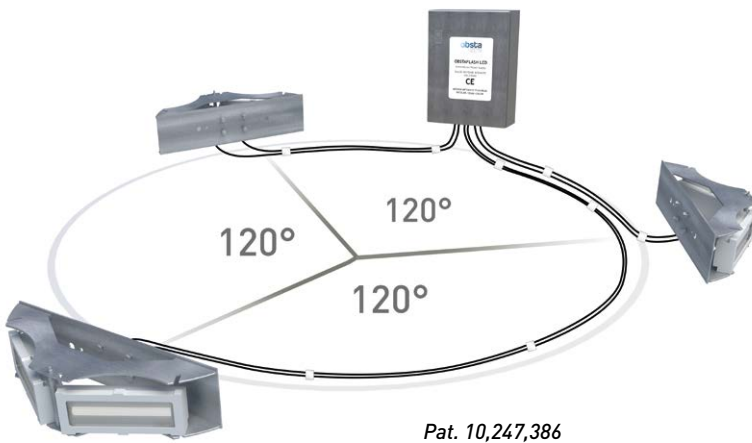

Kit including 3 Obstaflash120

- 2 led projectors with 10 meters cable
- Aluminium and glass envelope
- Connection with connectors for dual color and gland for red only
- Precise optic for optimal power consumption,
- Electronic deported in external cabinet



Power cabinet

- Stainless enclosure
- Surge protection
- Test button for day and night, 1 luminous indicator per white led projector,
- Modular design,
- Alarm contact
- Master/slave configuration for multiple cabinet
- Connection terminal for 48V low intensity at intermediale level working at night only
- Available with or without back-up power supply



Product range OBSTAFLASH OFI120

Kit including 3 Obstaflash120 medium intensity flashheads + power supply at same level,
ICAO White and Red Medium intensity type A and B & C / CAA / STAC

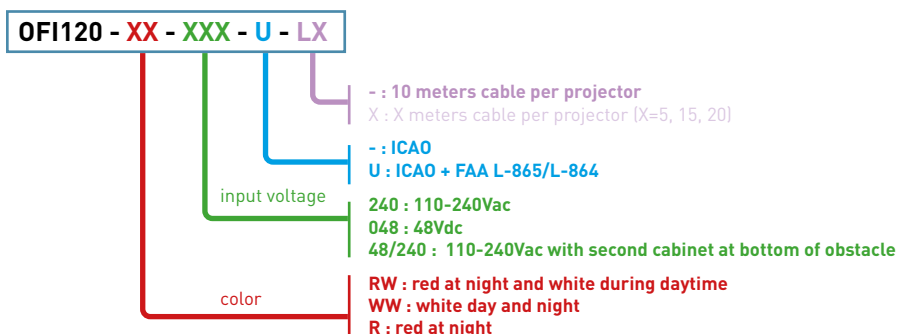



COMPOSITION PER ITEMS

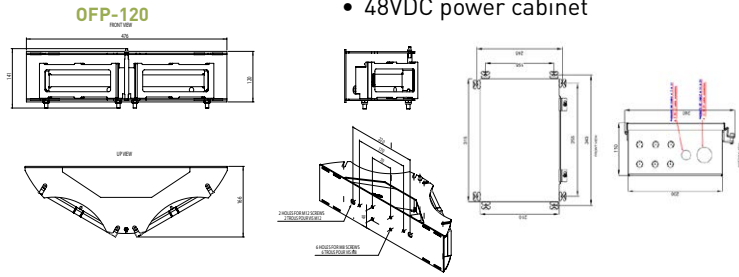

- 48VDC power cabinet

| | |
|--|--|
| IP degree for power cabinet | 65 in vertical position |
| Operating temperature | -30° to +55°C |
| Input voltage | 110 VAC to 240 VAC 50 to 60 Hz or 48VDC +/-10% |
| Cable entry for flashhead, power supply, photocell and alarm | 4 nickel plated brass |

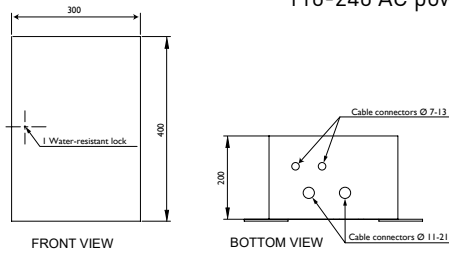

- 110-240 AC power cabinet

ACCESSORIES

- GPS part number 113746 for wireless synchronization
- 48vdc photocell part number 100755
- 48Vdc battery cabinet (input voltage 100-240VAC) for 12 hours back-up part number 113956 (see page 50)

MAIN CHARACTERISTICS

| Main characteristics | Effective Luminous output on site at 0° | | Color | | Beam Spread | | Flashes per minute |
|-------------------------------|---|----------------|-----------|--------------|-------------|------------|--------------------|
| | Day | Night | Day | Night | Vertical | Horizontal | |
| Red only (L864) | light off | 2000 Cd | light off | Red | > 3° | 360° | As per ICAO or FAA |
| White only (L865) | 20 000 Cd | 2000 Cd or off | White | White or off | | | |
| Dual color (L865/L864) | 20 000 Cd | 2000 Cd | White | Red | | | |

| | Designation | part number | Power supply | ICAO category | FAA category | System components |
|--|--------------------|-------------|--------------|-------------------------------|--|--|
| | OFI120-RW-48/240-U | 113758U | 110-230 VAC | Medium intensity type A and B | L-865/L-864, dual color medium intensity | 3 x OFP-120-RW-10L-U + OFP-CAB-6P-L-RW-048 + OFI-CAB-1E-RW-240-U |
| | OFI120-WW-48/240-U | 113757U | | Medium intensity type A | L-865 white medium intensity | |
| | OFI120-R-048/240 | 113756U | | Medium intensity type B | L-864 red medium intensity | 3 x OFP-120-R-10 + OFP-JB-6P-R + OFP-CAB-6P-1E-R-240 |
| | OFI120-RW-048-U | 113712U | 48VDC | Medium intensity type A and B | L-865/L-864, dual color medium intensity | 3 x OFP-120-RW-10L-U + OFP-CAB-6P-L-RW-048 |
| | OFI120-WW-048-U | 113711U | | Medium intensity type A | L-865 white medium intensity | |
| | OFI120-R-048 | 113710U | | Medium intensity type B | L-864 red medium intensity | 3 x OFP-120-R-10 + OFP-JB-6P-R + OFP-CAB-6P-6E-R-048 |
| | OFI120-RW-240-U | 113715U | 110-230 VAC | Medium intensity type A and B | L-865/L-864, dual color medium intensity | 3 x OFP-120-RW-10L-U + OFP-CAB-6P-L-RW-240-U |
| | OFI120-WW-240-U | 113713U | | Medium intensity type A | L-865 white medium intensity | |
| | OFI120-R-240 | 113714U | | Medium intensity type B | L-864 red medium intensity | 3 x OFP-120-R-10 + OFP-JB-6P-R+ OFP-CAB-6P-6E-R-240 |

• For more than 4 flasheads, "design your kit", see page 48-49



OFP-180 with complete remote power supply

The led OBSTAFASH medium intensity is a white, red or dual color flashing obstruction light with complete power supply in the cabinet. The OBSTAFASH is compliant with ICAO medium intensity type A and B/C.



Patent : EP 1966535B1 & US 7816843



2 or more Flashhead around obstacle

- 3 led projectors per flashhead
- Aluminium and glass envelope
- Modular design
- Easy maintenance
- Precise optic
- All electronic in stainless cabinet

Power cabinet

- Available in 48 Vdc or 120 /230 Vac
- Surge protection
- Automatic day/night switch with photocell
- Luminous indicator for each led circuits
- Test button for day and night
- Modular design
- Two side lights in option low intensity type
- Alarm contact
- Master/slave configuration for multiple lights synchronization



Patent : EP 1966535B1 & US 7816843

OFP - 180 - XX - XXX

- connexion X : projectors with X meter cable (1, 2, 5, 10m) without connector (no junction box)
- XL : projectors with X meter cable (1, 2, 5, 10) + connector (no junction box)
- JB : with junction box including 1 cable entry per projector and 1 cable entry to power supply
- JBL : with molded junction box with 6 connectors projector + one connector for power supply
- Color R : red projector
- RW : dual color projector
- horizontal beam 120 : 2 projectors
- 180 : 3 projectors
- 360 : 6 projectors



CABLE-OFP - 3P - XX - X

- X : X meter
- XS : X meters with one connector plug to junction box JBL or JBH
- Color R : red projector
- RW : dual color projector



OFP-CAB - XP - XE - XX - XXX

- input voltage 048 : power supply 48Vdc
- 240 : power supply 110-240Vac
- BAT : power supply 110-240Vac with 4 batteries 12V 12Ah
- Color R : red only
- RW : red and white
- WW : white day and night
- W : white during day only + low intensity at night
- connection to light(s) or projectors XE : X number of cable entry per light
- L : connector Lumberg (1 per dual color projector)
- quantity of projector XP : X total quantity of projectors (1 up to 12 dual color or 2 to 36 red)



WEIGHT & DIMENSIONS (IN MM)

OFP-180

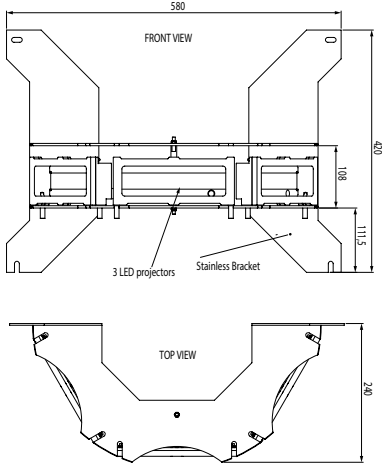

Weight: 14 kg, IP degree IP66



Power cabinet for 3 to 4 flashheads OFP-180-RW

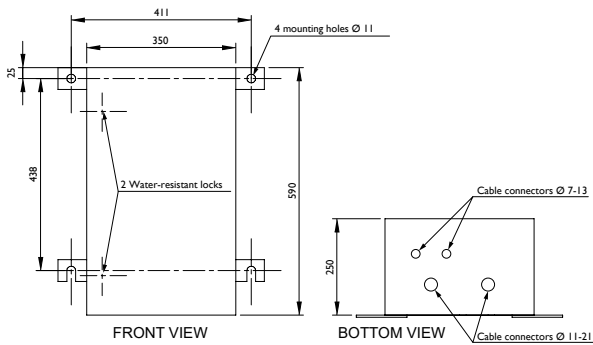

Power cabinet for 2 flashheads OFP-180-RW and 2 to 12 flashheads OFP-180-R

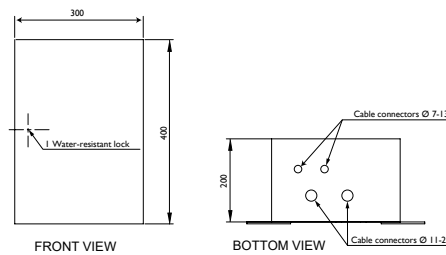

MAIN CHARACTERISTICS

| Main characteristics | Effective Luminous output on site at 0° | | Color | | Beam Spread | | Flashes per minute |
|----------------------|---|----------------|-----------|--------------|-------------|--------------------------------|--------------------|
| | Day | Night | Day | Night | Vertical | Horizontal | |
| Red only | light off | 2000 Cd | light off | Red | > 3° | 360° with 2 flashheads minimum | As per ICAO |
| White only | 20 000 Cd | 2000 Cd or off | White | White or off | | | |
| Dual color | 20 000 Cd | 2000 Cd | White | Red | | | |

MAIN REFERENCE

| Dual color obstruction lighting system type A+B/C (or white only) | Designation | Part number |
|---|-------------------------------|--------------------------|
| 2 to 4 Flashheads with stainless junction box | OFP-180-RW-JB | 113738 |
| Connecting cable between flashhead and power cabinet | CABLE-OFP-3P-RW (cable 8G1.5) | 113805 |
| Power cabinet | OFP-CAB-XP-XE-RW-XXX | See p 53 for designation |

| Red only obstruction lighting system type B/C | Designation | Part number |
|--|------------------------------|--------------------------|
| 2 to 12 Flashheads with stainless junction box | OFP-180-R-JB | 113745 |
| Connecting cable between flashhead and power cabinet | CABLE-OFP-3P-R (cable 5G1.5) | 113160 |
| Power cabinet | OFP-CAB-XP-XE-R-XXX | See p 53 for designation |



OFP-120 with complete remote power supply

The led OBSTAFASH medium intensity is a white, red or dual color flashing obstruction light with complete power supply in the cabinet. The OBSTAFASH is compliant with ICAO medium intensity type A and B/C.



3 or more Flashhead around obstacle

- 2 led projectors per flashhead
- Aluminium and glass envelope
- Modular design
- Easy maintenance
- Precise optic
- All electronic in stainless cabinet

Power cabinet

- Available in 48 Vdc or 120 /230 Vac
- Surge protection
- Automatic day/night switch with photocell
- Luminous indicator for each led circuits
- Test button for day and night
- Modular design
- Two side lights in option low intensity type
- Alarm contact
- Master/slave configuration for multiple lights synchronization

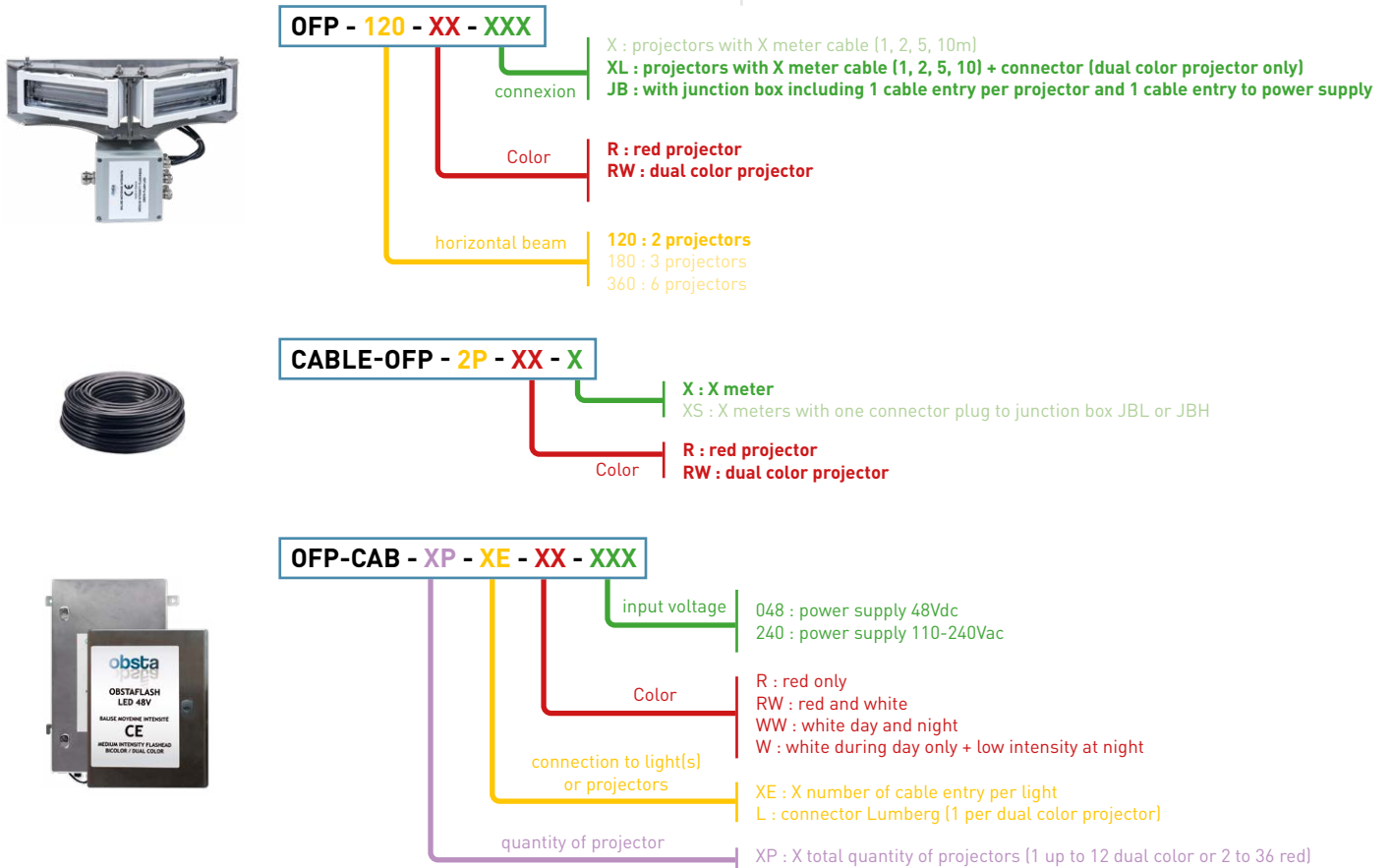



WEIGHT & DIMENSIONS (IN MM)

OFF-120

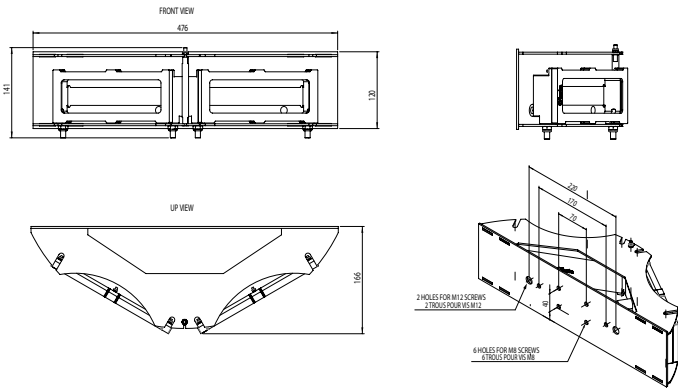

Power cabinet for 4 to 6 flashheads OFF-120-RW

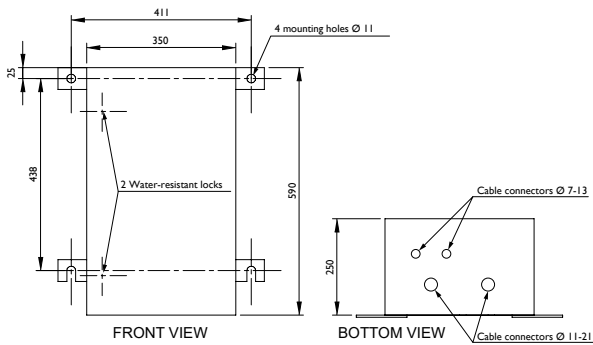

Power cabinet for 3 flashheads OFF-120-RW and 3 to 12 flashheads OFF-120-R

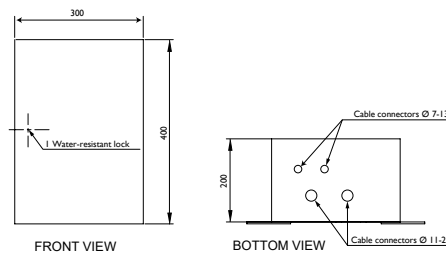

MAIN CHARACTERISTICS

| Main characteristics | Effective Luminous output on site at 0° | | Color | | Beam Spread | | Flashes per minute |
|----------------------|---|----------------|-----------|--------------|-------------|--------------------------------|--------------------|
| | Day | Night | Day | Night | Vertical | Horizontal | |
| Red only | light off | 2000 Cd | light off | Red | > 3° | 360° with 3 flashheads minimum | As per ICAO |
| White only | 20 000 Cd | 2000 Cd or off | White | White or off | | | |
| Dual color | 20 000 Cd | 2000 Cd | White | Red | | | |

MAIN REFERENCE

| Dual color obstruction lighting system type A+B/C (or white only) | Designation | Part number |
|---|-------------------------------|--------------------------|
| 3 to 6 Flashheads with stainless junction box | OFF-120-RW-JB | 113747-JB |
| Connecting cable between flashhead and power cabinet | CABLE-OFP-2P-RW (cable 8G1.5) | 113805 |
| Power cabinet | OFF-CAB-XP-XE-RW-XXX | See p 53 for designation |

| Red only obstruction lighting system type B/C | Designation | Part number |
|--|------------------------------|--------------------------|
| 3 to 12 Flashheads with stainless junction box | OFF-120-R-JB | 113752-JB |
| Connecting cable between flashhead and power cabinet | CABLE-OFP-2P-R (Cable 4X1.5) | 113161 |
| Power cabinet | OFF-CAB-XP-XE-R-XXX | See p 53 for designation |



Design your Medium intensity kit with flashheads OFP-XXX.. with projectors 120, 180, 360° and with a power supply OFP-CAB-XX...

1. Choose the flashheads

The OFP medium intensity series is available in 3 configurations OBSTAFLASH120, OBSTAFLASH180 and OBSTAFLASH 360 in dual color or red only.

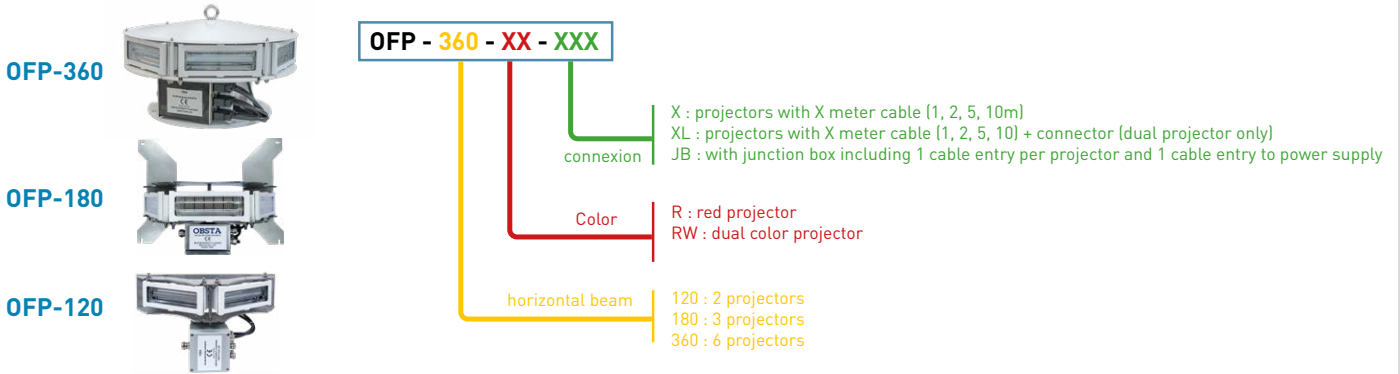

2. Define the power cabinet

Product range OFC-CAB. OBSTA Cabinet for OFC with/without low intensity. The power cabinet depends on the number of flash-heads, their configuration (2, 3 or 6 projectors) and their color (red, white or dual color)

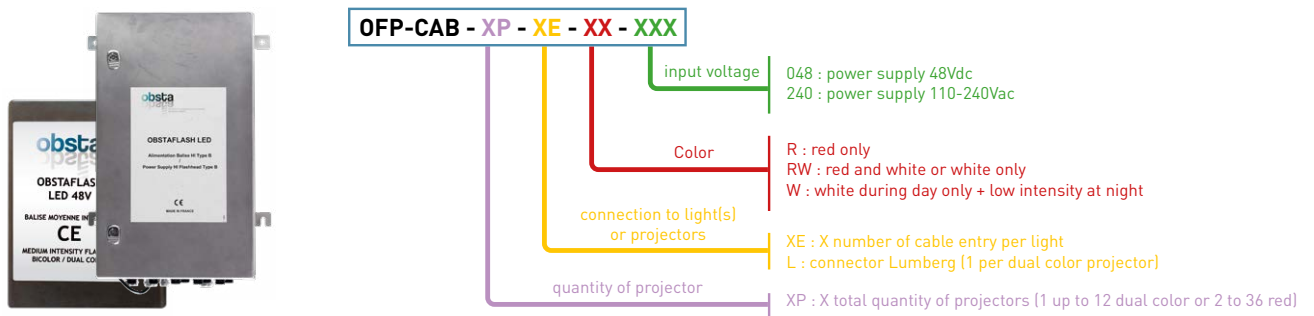

3. Junction box in option (if not already coded with the flashhead)

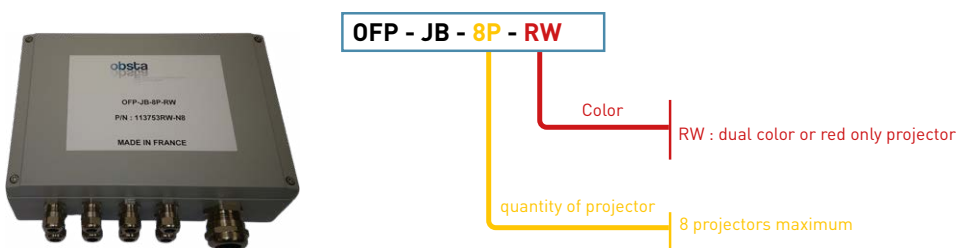

4. cable in option

Interconnecting cable between OFP junction box and OFP cabinet. Cable depending on numbers of projectors and their color.

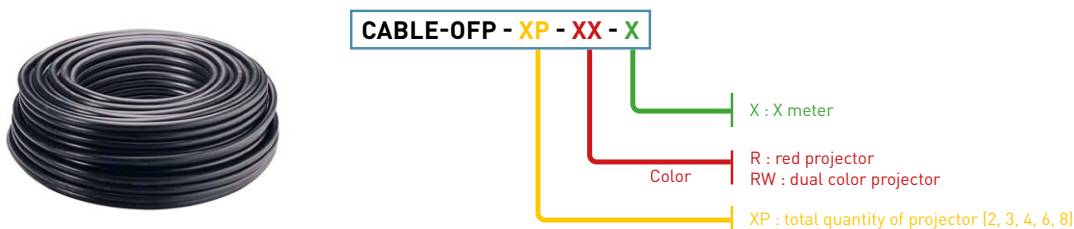



Typical configuration

4 dual color obstafash120 + 15 meters molded cable + junction box + power cabinet

| Quantity | Designation |
|----------|-------------------|
| 4 | OFP-120-RW-15 |
| 1 | OFP-JB-8P-RW |
| 1 | OFP-CAB-8P-RW-240 |
| 1 | Photocell-48 |
| X meters | cable OFP-8P-RW-X |

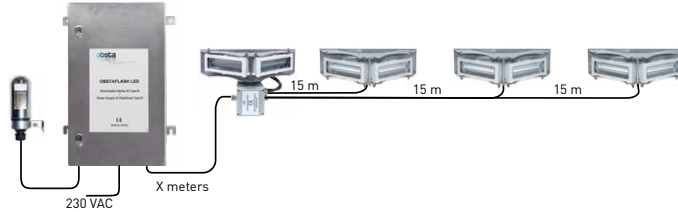

6 dual color obstafash120 with junction box, interconnecting cable & power cabinet

| Quantity | Designation |
|----------|-----------------------|
| 6 | OFP-120-RW-JB |
| 1 | OFP-CAB-12P-6E-RW-240 |
| 1 | Photocell-48 |
| X meters | shielded cable 10G1,5 |

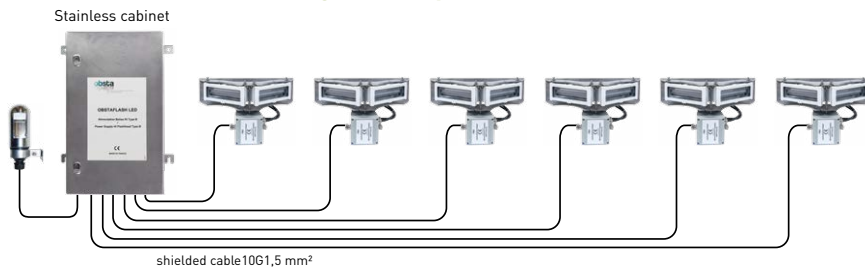

4 red obstafash120 with junction box & power cabinet

| Quantity | Designation |
|----------|----------------------|
| 4 | OFP-120-R-JB |
| 1 | OFP-CAB-8P-4E-R-240 |
| 1 | Photocell-48 |
| X meters | shielded cable 3G1,5 |

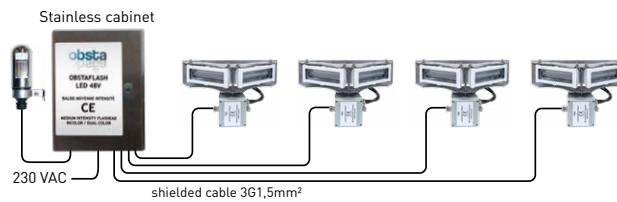

2 dual color obstafash180 + junction box & power cabinet

| Quantity | Designation |
|----------|----------------------|
| 2 | OFP-18-RW-JB |
| 1 | OFP-CAB-6P-2E-RW-240 |
| 1 | Photocell-48 |
| X meters | shielded cable 8G1,5 |

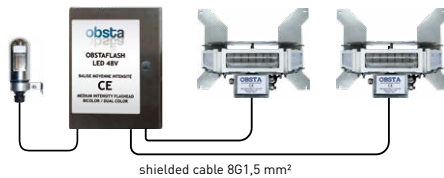

4 dual color obstafash180 + junction box & power cabinet

| Quantity | Designation |
|----------|-----------------------|
| 4 | OFP-18-RW-JB |
| 1 | OFP-CAB-12P-4E-RW-240 |
| 1 | Photocell-48 |
| X meters | shielded cable 8G1,5 |

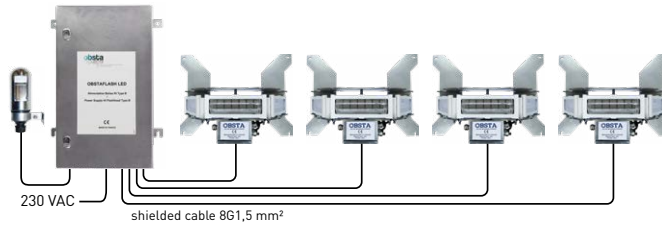

4 red obstafash180 + junction box & power cabinet

| Quantity | Designation |
|----------|----------------------|
| 4 | OFP-18-R-JB |
| 1 | OFP-CAB-12P-4E-R-240 |
| 1 | Photocell-48 |
| X meters | shielded cable 3G1,5 |

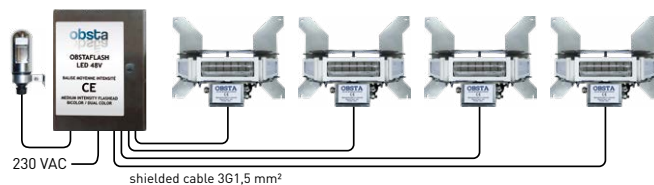



CONTROLLER FOR RED LIGHTS

Stainless control box to facilitate the implementation and monitoring of red medium and low intensity OBSTA lights. These metal boxes are suitable for EMC environments and severe climatic conditions.



- cable inputs by gland nickel plated brass
- 8 terminal connections for max 8 medium intensity lights and/or low intensity lights red fixed or mimic with medium intensity red flashing
- 1 visual indicator per light (or group of light)
- surge protection
- connection of optional photocell
- alarm relay per lamp, for the photocell and for the power supply
- on/off switch and remote/manual switch to bypass the photocell or GPS

Les dimensions sont en mm
All dimensions are in mm

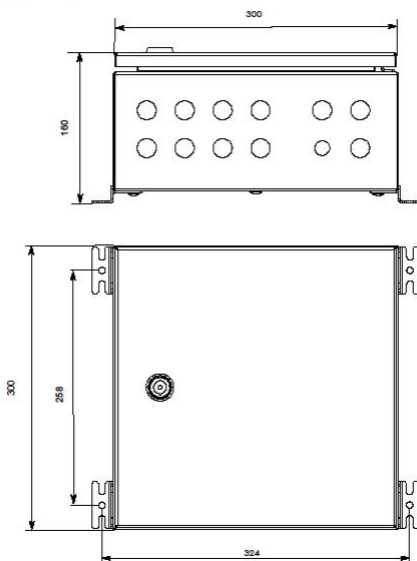

MAIN CHARACTERISTICS

| Part number | Voltage | Number of OBSTA lights |
|-------------|-------------|--|
| 113176-240 | 110-240 VAC | 8 OFC and/or NAVILATE 240 V (or 5 OFI360 240 V only) |
| 113176-048 | 48 VDC | 8 OFC and/or NAVILETE 48 VDC |



PHOTOCELL



Photocell for night only operation or dual color light

- plug-in modular construction with plated contact surfaces
- automatic control of the obstruction lighting according to ambient light
- timer to prevent the functioning of the cell at inopportunes times (eg lightning)
- energy savings
- increased operational autonomy (power per power cabinet)
- works with all types of OBSTA lights (110 VAC, 230VAC, 48VDC and 24VDC) for night only operation or changing mode (day/night)
- 2 sensors for twilight and night mode

MAIN CHARACTERISTICS

| PHOTOCELL | Power supply | Switching threshold of the cell |
|-----------|------------------|---------------------------------|
| 100756 | 110 to 240 VAC | 50 lux |
| 100757 | 12, 24 or 48 VDC | and 500 lux |

Typical configuration for towers with 2 levels of obstruction lights

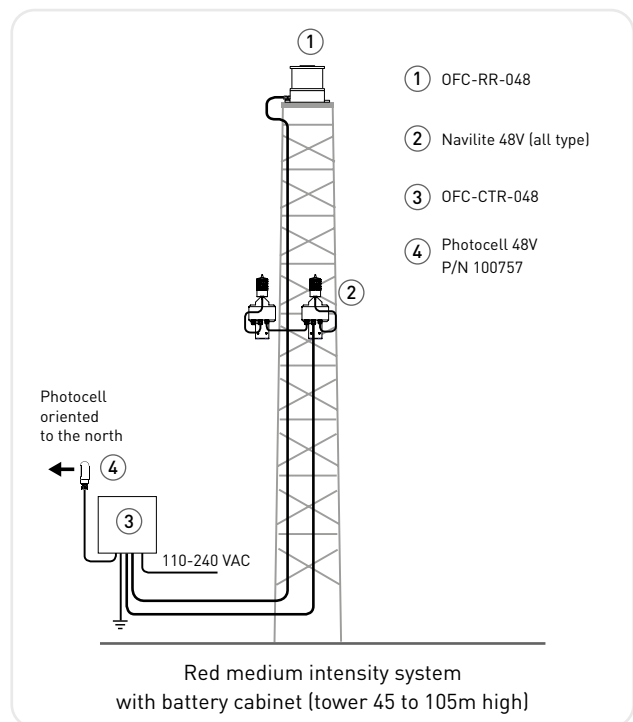
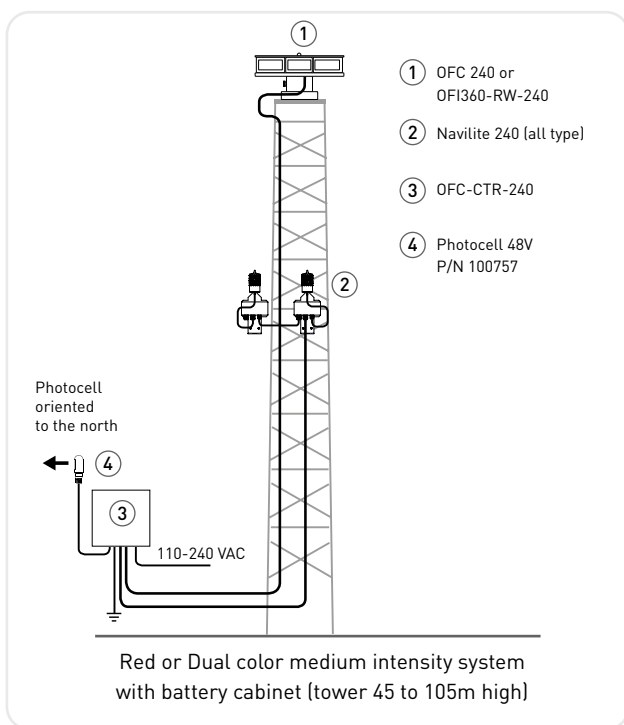



LED OBSTAFLASH HI type A

The led OBSTAFLASH high intensity is a white color flashing obstruction light.

The OBSTAFLASH is compliant with ICAO high intensity type A, and in option medium intensity type B or C at night.



Patent : EP 1966535B1 & US 7816843

Flashhead

- 8 led dual color projectors
- Aluminium and glass envelope
- Modular design
- Easy maintenance
- Precise optic, low power consumption

Description

- 200 000 candelas during day time in white
- 20 000 candelas during twilight in white,
- 2000 candelas during the night white (red medium intensity type B or C in option),
- Rugged design
- Easy installation

Power cabinet per flashead

- Weathertight stainless steel enclosures (in vertical position),
- Surge protection
- Alarm monitoring
- Automatic day/twilight/night switch by photocell
- Luminous indicator for each projector
- Test button for day, twilight and night mode
- Modular design
- Low power consumption

Product range OBSTAFLASH OFH ICAO High Intensity type A / CAA

OFH-120 - XX - XXX

input voltage

240 : 110-240Vac

color

WW : white day tiwilight and night

RW : red at night and white during daytime & twilight



WEIGHT AND DIMENSIONS (IN MM)

Flashhead

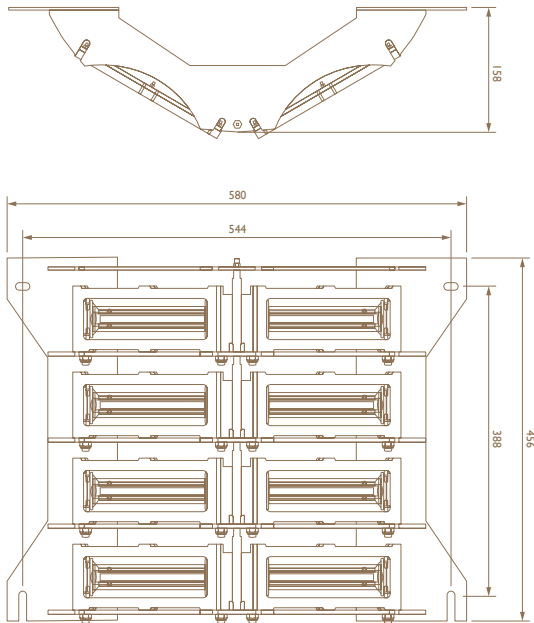

COMPOSITION

| Obstruction lighting system 230 V - 50Hz | Part Number |
|---|-------------|
| Flashead + power cabinet | 113780 |
| Photocell day/twilight/night | 113135 |
| HI controller | 113625L |

OTHER CHARACTERISTICS

- IP degree: 66 for the projectors and 65 for the stainless cabinet in vertical position,
- Weight per cabinet: 15kg,
- Weight per flashhead: 18kg (1kg per projector and 10kg for the stainless bracket),
- Temperature -30°C to +55°C,
- day/twilight/night automatic switch by external photocell
- Autonomous synchronisation (master/slave configuration) or with external controller
- GSM modem with optical network for remote diagnostic.

POWER CABINET

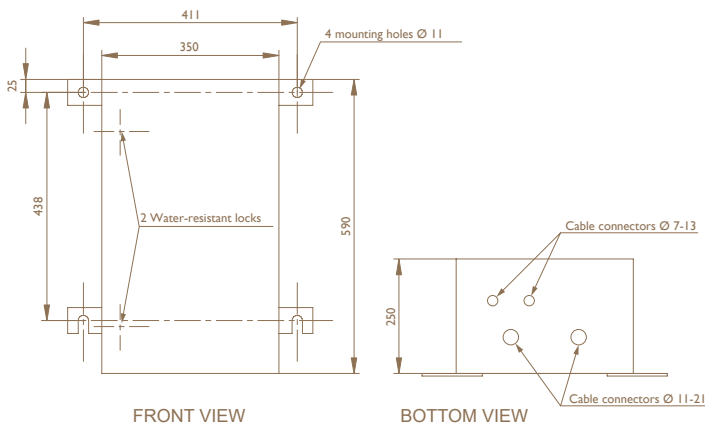

| Main supply | Frequency | Average wattage during day time |
|-----------------|-----------|---------------------------------|
| 110V up to 240V | 50/60 Hz | 160 W |

MAIN REFERENCE

| Designation | part number | Luminous Intensity | | | Beam spread | | Flashes/minute |
|-----------------------|---------------|--------------------|-----------|---------|-------------|------------|----------------|
| | | Day | Twilight | Night | Vertical | Horizontal | |
| OFH-120-WW-240 | 113780 | 200 000 Cd | 20 000 Cd | 2000 Cd | > 3° | 120° | 40 |



BALISOR

High-voltage lines are major hazards for low-flying aircraft. Placing beacons on pylons is not sufficient to ensure safety due to the very long spans of cable (extract of Aerodrom Design Manual chapter 14.7 annex 4).

The BALISOR® system (created by OBSTA in the 60's) is a beacon for high voltage lines. Its conductors take the power required directly from the line.

The system is, therefore, completely self-contained.

Our standard model of BALISOR® fall into the ICAO low intensity category.

The neon discharge offers :

- inherent generation of «aviation» red light,
- a very long life, essential to continuous operation of highvoltage lines.
- light intensity remains the same whatever is the current crossing the high voltage cable.

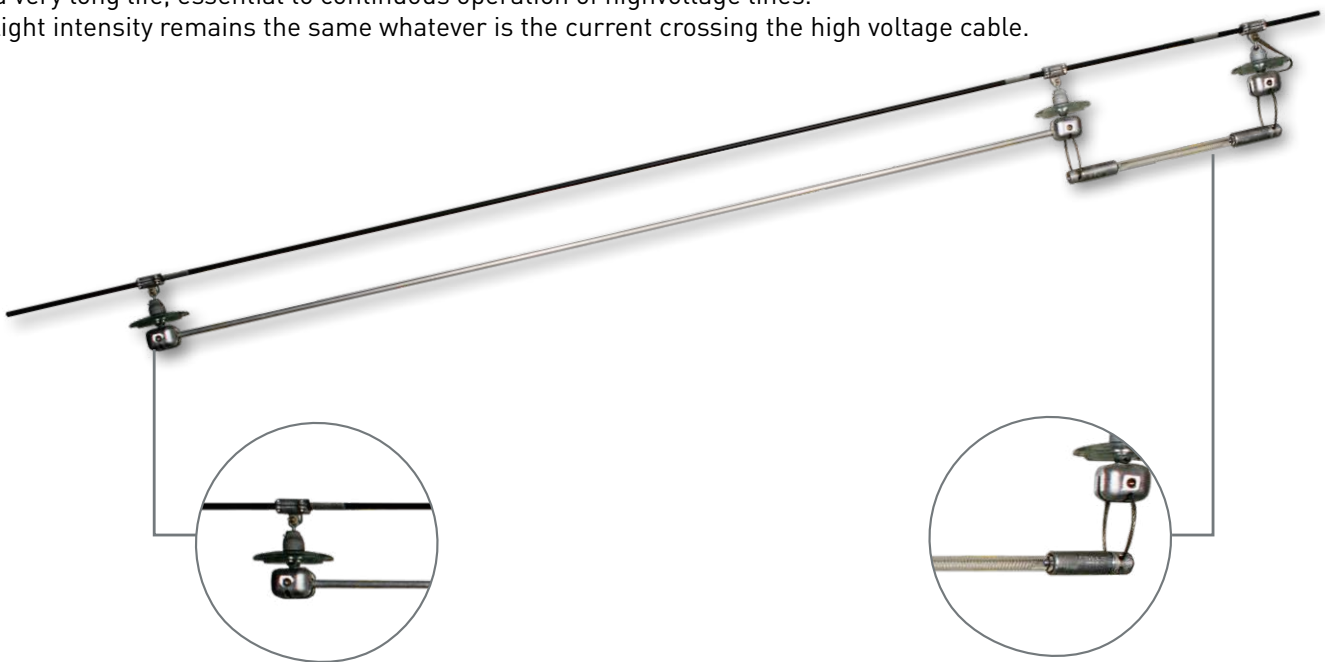

Fixing accessories

- fixing accessory and capacitive elements in aluminium
- flexible mounting - no rigid fixation
- clamp adapted to the diameter of the cable
- exists with cable antenna

Cold neon discharge light

- hard glass envelope and tube
- "aviation" red light
- very long lifetime,
- excellent luminous efficiency
- low power consumption

MAIN CHARACTERISTICS

| Designation | Part number | Luminous intensity | Voltage of the line | Interference suppression | Typical lifetime |
|---|---------------|--------------------|---------------------|--------------------------|------------------|
| BALISOR-lamp-B49 | 100618 | > 10 Cd | 60 kV to 550 kV | yes | > 100 000 h. |
| BALISOR-lamp-B33 (for balisor with cable antenna) | 100616 | > 10 Cd | 60 kV to 400 kV | yes | > 100 000 h. |



WEIGHT AND DIMENSIONS (IN MM)

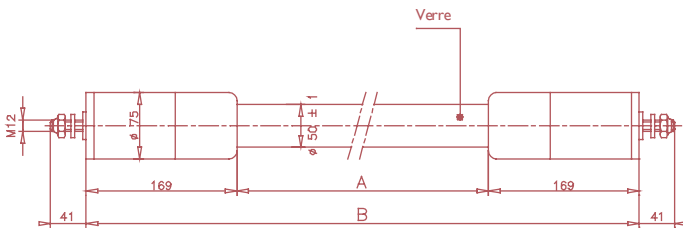

| Type | A | B | Weight |
|---------------|-----------|-----------|--------|
| Lamp type B49 | 563 +/- 5 | 901 +/- 5 | 4.7 kg |
| Lamp type B33 | 376 +/- 5 | 714 +/- 5 | 4 kg |

Length of the drift depending on the voltage

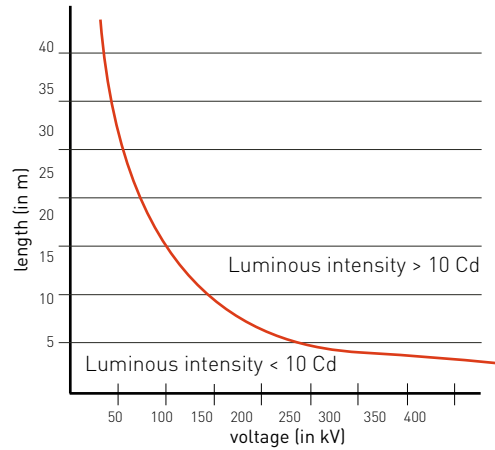

| Unit weight | Code | Désignation | Number of elements depending on voltage line | | | |
|-------------|---------|-----------------------------|--|--------|--------|-----------------|
| | | | 115 kV | 132 kV | 220 kV | 380 kV and more |
| 0.85 kg | 100637 | Clamp | 7 | 6 | 4 | 3 |
| 3.50 kg | 100621* | Insulator | 7 | 6 | 4 | 3 |
| 0.10 kg | 100636* | Shunt braid | 1 | 1 | 1 | 1 |
| 0.50 kg | 100628 | Simplified auxiliary holder | 7 | 6 | - | - |
| 2.00 kg | 100631 | Lampe holder | - | - | 2 | 2 |
| 1.35 kg | 100632 | Auxiliary tubing holder | - | - | 2 | 1 |
| 1.90 kg | 100623 | Auxiliary tubing | 5 | 4 | 2 | 1 |
| 0.50 kg | 100606 | Flexible connector | 2 | 2 | - | - |
| 0.50 kg | 100624 | Lamp end suspender | 2 | 2 | - | - |
| 4.70 kg | 100618 | BALISOR B lamp | 1 | 1 | 1 | 1 |
| 4.00 kg | 100616 | BALISOR B33 | - | - | - | - |

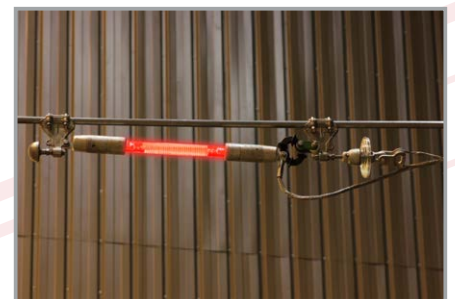
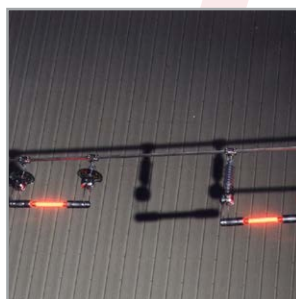
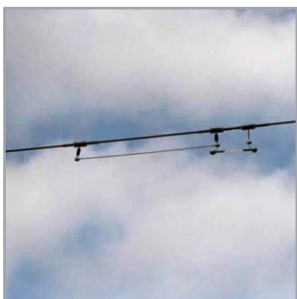

Balisor with rigid capacitive element

Balisor with cable antenna



WARNING SPHERES

Those spherical markers are compliant with International Civil Aviation Organization (ICAO) recommendations annex 14 chapter 6 :

Paragraph 6.2.8: A marker displayed on a overhead wire, cable etc. should be spherical and not have a diameter of not less than 600mm

Paragraph 6.2.10: A marker should be of one color. When installed, white and red, or white and orange markers should be displayed alternately. The color selected should contrast with the background against it will be seen.



Warning spheres

- quick installation: easy and quick assembly with 6 nuts (no losing bolts)
- diameter: 610 mm
- material: polyethylene
- weight: 4 kg
- colors : orange aviation or white
- clamps: adapted to the diameter of the cable
- optional armor rods for cable and OPGW (consult us)

MAIN CHARACTERISTICS

| OBSTA part number | Color * | Clamp diameter * | Armor rod * |
|-------------------|--------------------------------------|------------------------|-------------|
| 113655 | Red aviation, orange aviation, white | From 9.3 mm to 54.8 mm | Optional |

* to be defined when ordering



ALUMINIUM WARNING SPHERES

The spherical markers are compliant with International Civil Aviation Organization (ICAO) recommendations annex 14 chapter 6 :

Paragraph 6.2.5.4: A marker displayed on an overhead wire, cable, etc., should be spherical and have a diameter of not less than 60 cm.

Paragraph 6.2.5.5: The spacing between two consecutive markers or between a marker and a supporting tower should be appropriate to the diameter of the marker, but in no case should the spacing exceed 30 meters where the marker diameter is 60 cm. Where multiple wires, cables, etc., are involved, a marker should be located not lower than the level of the highest wire at the point marked.



Warning spheres

- Designed for high voltage cable up to 420KV
- No losing parts during installation with only 2 screws and 4 draw latches
- overall diameter 600mm
- material: aluminum
- weight: 6.5kg
- color: white, red or aviation orange
- clamps depending on the diameter of the cable

MAIN CHARACTERISTICS

| OBSTA part number | Color * | Diameter of clamps * |
|-------------------|----------------------|-----------------------|
| 113655AL | Red, orange or white | from 9 mm up to 67 mm |

* to be specified at time order



EFFAROUCHEUR

This bird diverter is designed to increase the visibility of overhead lines and reduce the incidence of bird collisions with overhead cables. Extensive field studies have shown that when installed properly diverters significantly decrease bird strikes.



DESCRIPTION

- Easy “bump and snap” installation on the cable
- No special tools required
- Simple, cost-effective design
- Lightweight (total weight = 180g)
- Manufactured from UV-stabilized polycarbonate and polyethylene materials
- All metal hardware is corrosion-resistant stainless steel

MAIN CHARACTERISTICS

| Part number | Operating temperature | Weight | Cable diameter | Color |
|-------------|-----------------------|--------|----------------|--------|
| 100951 | 100 °C max | 180 g | Ø up to 40 mm | Yellow |

OBSTA DIAGNOSTIC SNMP

The «OBSTA diagnostic SNMP» kit allows a precise remote diagnostic of each items of the obstafash led type in order to facilitate their currative and preventive maintenance of the projectors and their respective power supply.

This kit includes a controller using with a touch screen through SNMP and internet capability.

OBSTA diagnostic SNMP



Select Lamp

Select a lamp

Lamp

Date Test - Lamp Test

| # | Date | Status | Issue | SNPS |
|-------|------------------|--------|-------|------|
| 11270 | 12/11/2014 10:21 | OK | Day | OK |
| 11270 | 12/11/2014 10:21 | OK | Day | OK |
| 11270 | 12/11/2014 10:18 | OK | Day | OK |
| 11270 | 12/11/2014 10:08 | OK | Day | OK |
| 11270 | 12/11/2014 10:27 | OK | Day | OK |
| 11270 | 12/11/2014 10:07 | OK | Day | OK |
| 11277 | 12/11/2014 10:06 | OK | Day | OK |
| 11274 | 12/11/2014 10:06 | OK | Day | OK |
| 11271 | 12/11/2014 10:10 | OK | Day | OK |
| 11268 | 12/11/2014 10:00 | OK | Day | OK |

Main Board Status - 12/11/2014 13:39

Mode Day - Alarm Error No



| Level | 06 | 07 | 08 | 09 | 10 | 11 | 12 | 13 | 14 |
|-----------------|----|----|----|----|----|----|----|----|----|
| Output | 1 | 2 | 3 | 4 | 5 | 6 | 7 | 8 | 9 |
| Reverse Voltage | 10 | 10 | 11 | 11 | 11 | 12 | 12 | 12 | 12 |
| Active Voltage | 18 | 18 | 18 | 18 | 18 | 18 | 18 | 18 | 18 |

Features of the controller

Recording the status of the lights at preset interval and display through a touch screen:

1/ Status of the lights and their power supply

- Status of the led projectors and their associated power supply
- Status of the synchronisation coming from the GPS or other interface
- Status of the day/night mode
- Temperature inside the power supply (only with the gprs modem)
- Configuration of the flashheads

2/ Telemetric curves

- Voltage of each led circuits
- Voltage of the power supply or batteries
- Temperature (only available with the gprs modem)

Requirement for the web interface if connected to internet

2 solutions are possibles :

- either by using the OBSTA web site
- either through a dedicated server using a WAR application (code and support given by OBSTA).

Requirement for the server : **Postgres** (database) + **tomcat**



SOLAR POWER SYSTEM

This kit consists of one or two lamps in redundancy, 12V to 48 VDC, low and/or medium intensity, that must be installed on top of the obstacle.

These solar kits are designed for long life (size of the batteries includes more than 5 days fo autonomy) and easy access for the maintenance fo the batteries

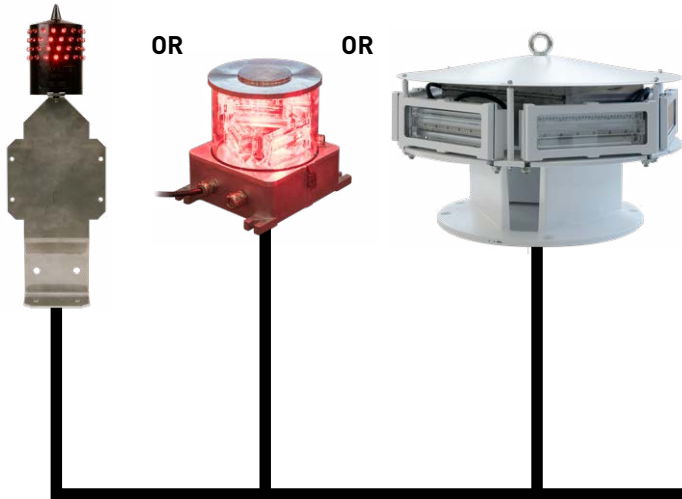

GPS synchroniser

- one or more photovoltaic panel(s)
- a charge controller
- long lifetime gel battery
- an aluminium frame with angle or vertical mounting bracket and battery box
- optional : 2 lights in redundancy with tilt of the main light to the emergency light in case of failure
- nominal battery capacity : 5 to 10 days depending on latitude
- easy access for maintenance of the battery

The size of the solar panel and of the battery depends on the location of the installation. Please contact us for more information.

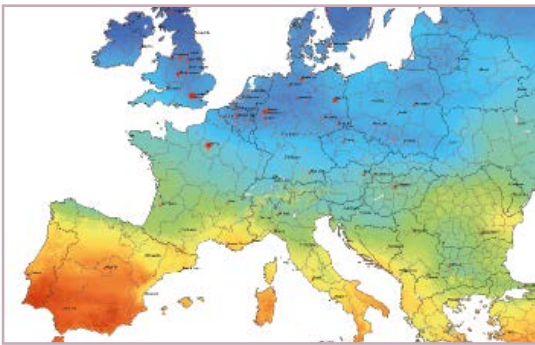



HELITE-G-24

Helipad light (TLOF)



Key points

- hard glass
- compact
- low power consumption
- compliant with ICAO Annex 14 Volume II
- DC power supply with battery cabinet in option
- LED technology (no maintenance)
- frangible support in option
- light weight
- feet in option

dimensions (in mm)

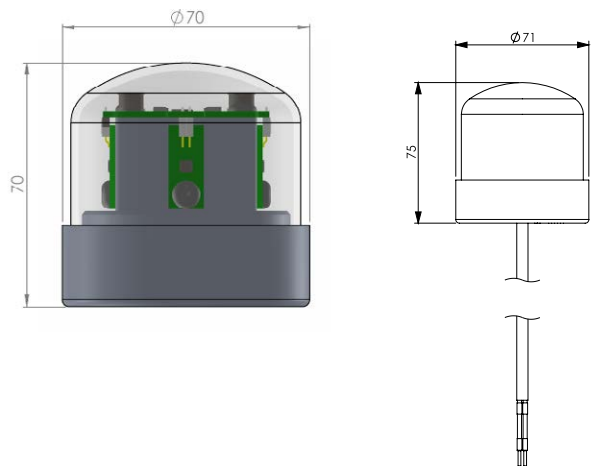

In option

- 24 VDC power cabinet for 12 hours back-up (powered through 110 to 240 VAC)
- L-854 FM radio receiver/decoder is 100 % frequency and squelch field tunable within the 118-136 MHz air-band to switch on the lights with a series of 3, 5 or 7 microphones clicks.
- An integrated selectable timer shuts airfield lights off after 15, 30 or 60 minutes.

MAIN CHARACTERISTICS

| Designation | Part number | Operating temperature | Color | IP degree | Attachment | Luminous intensity | Power supply |
|-------------|-------------|-----------------------|-------|-----------|----------------------------------|--------------------|--------------|
| HELITE-G-24 | 113975 | -30/+60°C | green | IP66 | 1 NPT threaded holes or 3 M4 0.7 | >32cd | 3w 10-36Vdc |

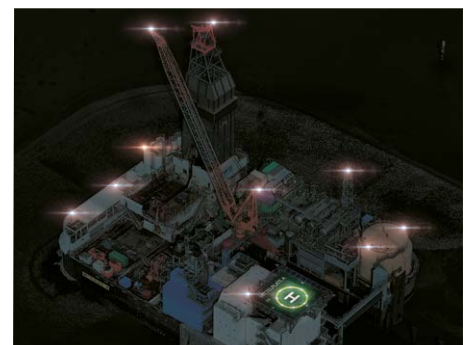
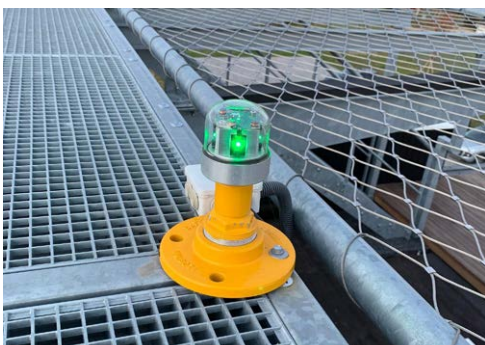

Some OBSTA references on all continents and conditions

FRANCE, Oil and Gas Chimney

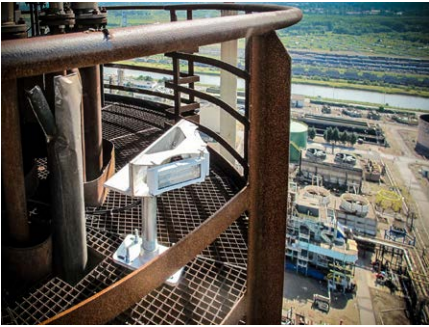

SPAIN, Barcelona Tower



MALAYSIA, Kuala Lumpur

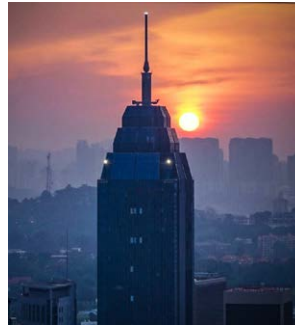

PARIS, Eiffel Tower

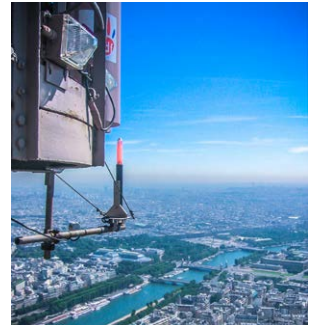

FRANCE, Millau



CHINA, Hong Kong

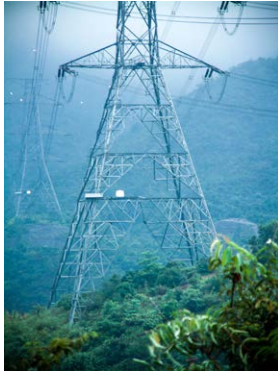

PARIS, Montparnasse Tower

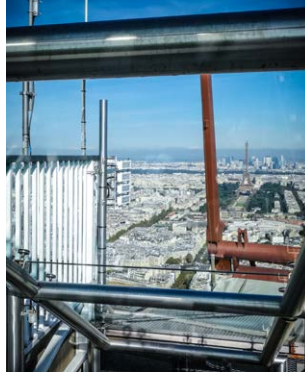

USA, Texas



BRUXELLES, Diegem



ABU DHABI, Four Seasons Hotel



BEIRUT, Damac Vercase Tower



ST PETERSBURG, Gazprom tower



NIGERIA, Lagos, Eko Towers



BELGIUM, Bruxelles airport

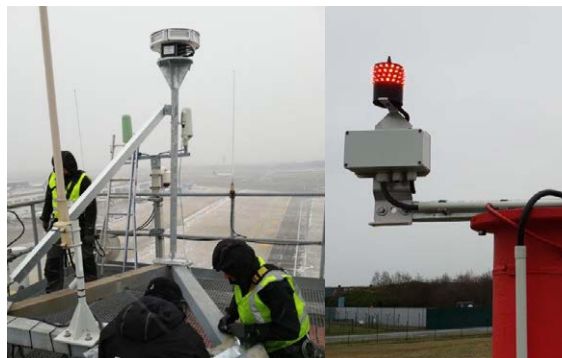

RUSSIA, Moscow



EGYPT, Ain Sokhna



ABU DHABI, UAE



Paris Airport, FRANCE. Working since 1973!



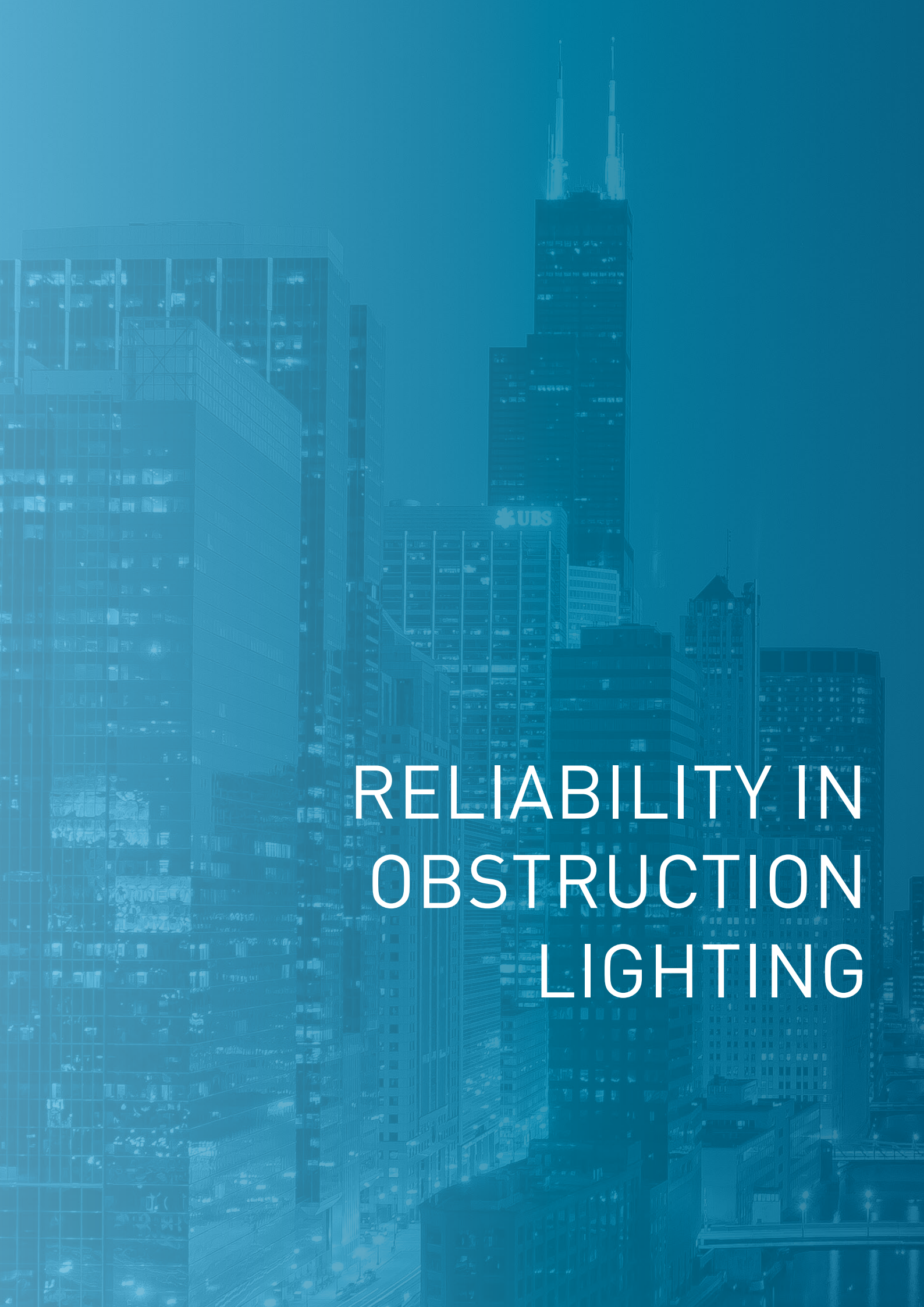

RELIABILITY IN
OBSTRUCTION
LIGHTING



RELIABILITY
IN OBSTRUCTION
LIGHTING



FRANCE

Head Office

2 rue Troyon
92316 Sèvres CEDEX
Tel. +33 1 41 23 50 10
e-mail : info@obsta.com
Web : www.obsta.com

Factory

3 impasse de la Blanchisserie
BP 56
51052 Reims CEDEX
Tel. +33 3 26 85 74 00

GERMANY

Feldstraße 9a
44867 Bochum
Tel. +49 2327 6057 0
e-mail : info@citel.de

USA

10108 USA Today Way
Miramar FL 33025
Tel. +1 954 430 63 10
e-mail : info@citel.us

UAE

PO Box 371315
Unit Number 4WB, 448,
Dubai Airport Free Zone
e-mail : info@obsta.com

www.obsta.com



A CITEL company

