

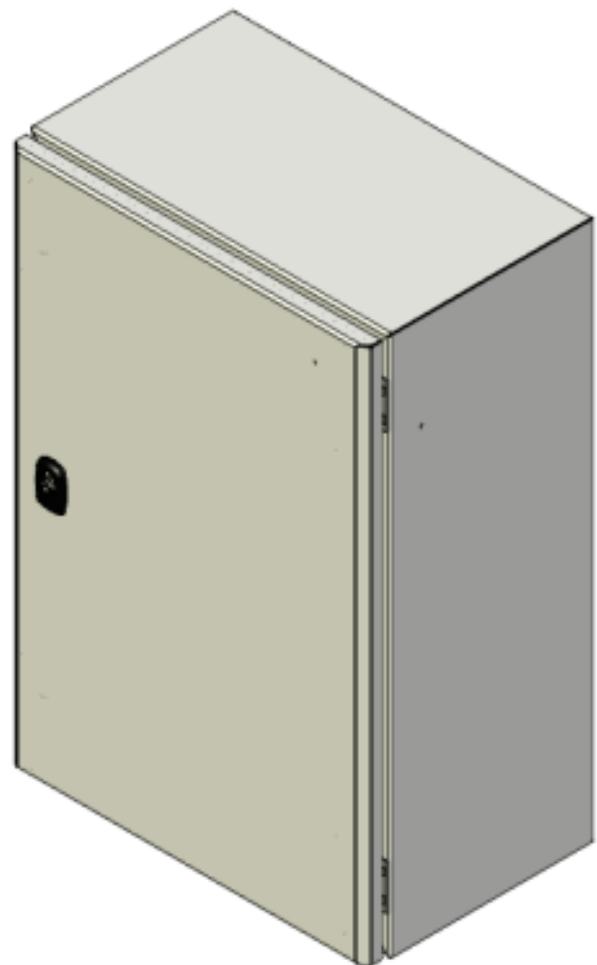

## USER MANUAL

OBSTA supply unit

48V-BAT-20Ah-AL // 113956B-AL



- 1. PRODUCT NAME AND PART NUMBER ..... 3**
- 2. CAUTION ..... 4**
- 3. WARRANTY ..... 5**
- 4. INTRODUCTION ..... 6**
  - 4.1. SCOPE .....6
  - 4.2. GENERAL DESCRIPTION.....6
  - 4.3. DIMENSION .....6
  - 4.4. BILL OF MATERIALS .....7
  - 4.5. POWER SUPPLY SPECIFICATIONS .....9
- 5. WIRING .....10**
  - 5.1. INTERNAL WIRING .....10
  - 5.2. BATTERY .....11
  - 5.3. PHOTOCCELL (OPTION).....12
  - 5.4. ELECTRICAL DIAGRAM.....13
- 6. MAINTENANCE .....14**
  - 6.1. ANNUAL VISIT .....14
  - 6.2. SPARE PART .....14
- 7. APPENDIX .....15**
  - 7.1. BATTERY SPÉCIFICATIONS .....15

## 1. Product name and part number

Description	Part number (P/N)	Power supply	QR code
48V-BAT-20Ah-AL	113956B-AL	48Vdc +5% -15%	

## 2. Caution



- Do not proceed with any maintenance job when the product is under operation.
- Power supply must be shut down when opening the flash-head or the cabinet.
- Installation must be performed only by an electrically skilled operator and National electrical installation rules must be respected.
- Always wear appropriate Personal Protective Equipment (PPE) when installing, maintaining or servicing the system.
- Any installation or maintenance operation performed at height must be carried out in strict compliance with fall-protection procedures.
- Do not look directly at the projector while it is in operation: Led projectors produce brilliant flashes of lights which can result in temporary or permanent eye damage.
- OBSTA products may be affected by ESD, use state of the art precaution before manipulation.
- Unless otherwise specified, all cables must be shielded, and the shielding must be connected to ground.
- All cables connected to PCBs and terminal blocks must be equipped with a cable connector to prevent false contacts when connecting devices.



### 3. Warranty

OBSTA warrants the equipment described in the instruction manual and sold to purchasers to be free from defects in material and workmanship at the time of shipment. OBSTA's liability under this warranty being limited to repairing or replacing, at OBSTA's option, items which are returned to it prepaid within twenty-four (24) months from shipment to the original Purchaser, or twelve months from commissioning, and found, to OBSTA's satisfaction, to have been defective. In no event shall OBSTA be liable for consequential damages. NO PRODUCT IS WARRANTED AS BEING FIT FOR A PARTICULAR PURPOSE AND THERE IS NO WARRANTY OF MERCHANTABILITY.

This warranty applies only if: (I) the items are used solely under the operating conditions and in the manner recommended in OBSTA's instruction manual, specifications, or other literature; (II) the items have not been misused or abused in any manner or repairs attempted thereon; (III) written notice of the failure within the warranty period is forwarded to OBSTA and the directions received for properly identifying items returned under warranty are followed; and (IV) such return notice authorizes OBSTA to examine and disassemble returned products to the extent OBSTA deems necessary to ascertain the cause of failure. The warranties stated herein are exclusive.

THERE ARE NO OTHER WARRANTIES, EITHER EXPRESSED OR IMPLIED, BEYOND THOSE SET FORTH HEREIN, and OBSTA does not assume, nor does OBSTA authorize anyone else to assume for it, any other obligation or liability in connection with the sale or use of said products. OBSTA's liability on any claim of any kind, including negligence, for loss or damages arising out of or connected with the manufacture, sale, delivery, repair or use of any equipment or services provided by OBSTA shall in no case exceed the price allocable to the item or service or part thereof which gives rise to the claim.

The integrity and reliability of OBSTA aviation obstruction lighting systems is dependent on the use of OBSTA parts and components. To ensure the optimum performance and reliability of your OBSTA system, it is strongly advised that only components and modules manufactured by OBSTA be used.

## 4. Introduction

### 4.1. Scope

The OBSTA power supply unit ensures power supply to the light heads in the event of a power cut.

### 4.2. General description

The steel cabinet is connected to a 240Vac power supply, and contains input and output overvoltage protection, as well as 4 batteries to keep OBSTA lamps running for up to 12 hours in the event of a power supply.

### 4.3. Dimension

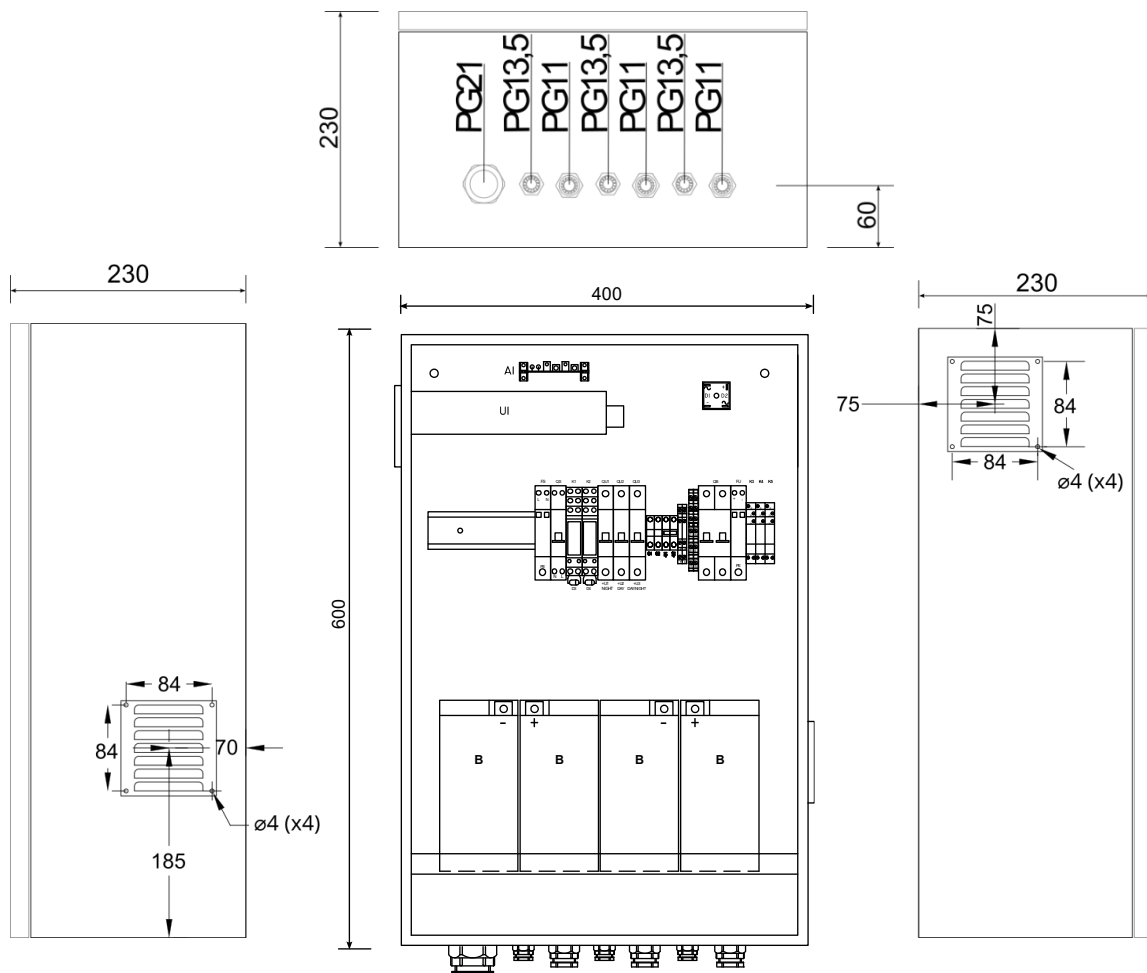

4.4. Bill of materials

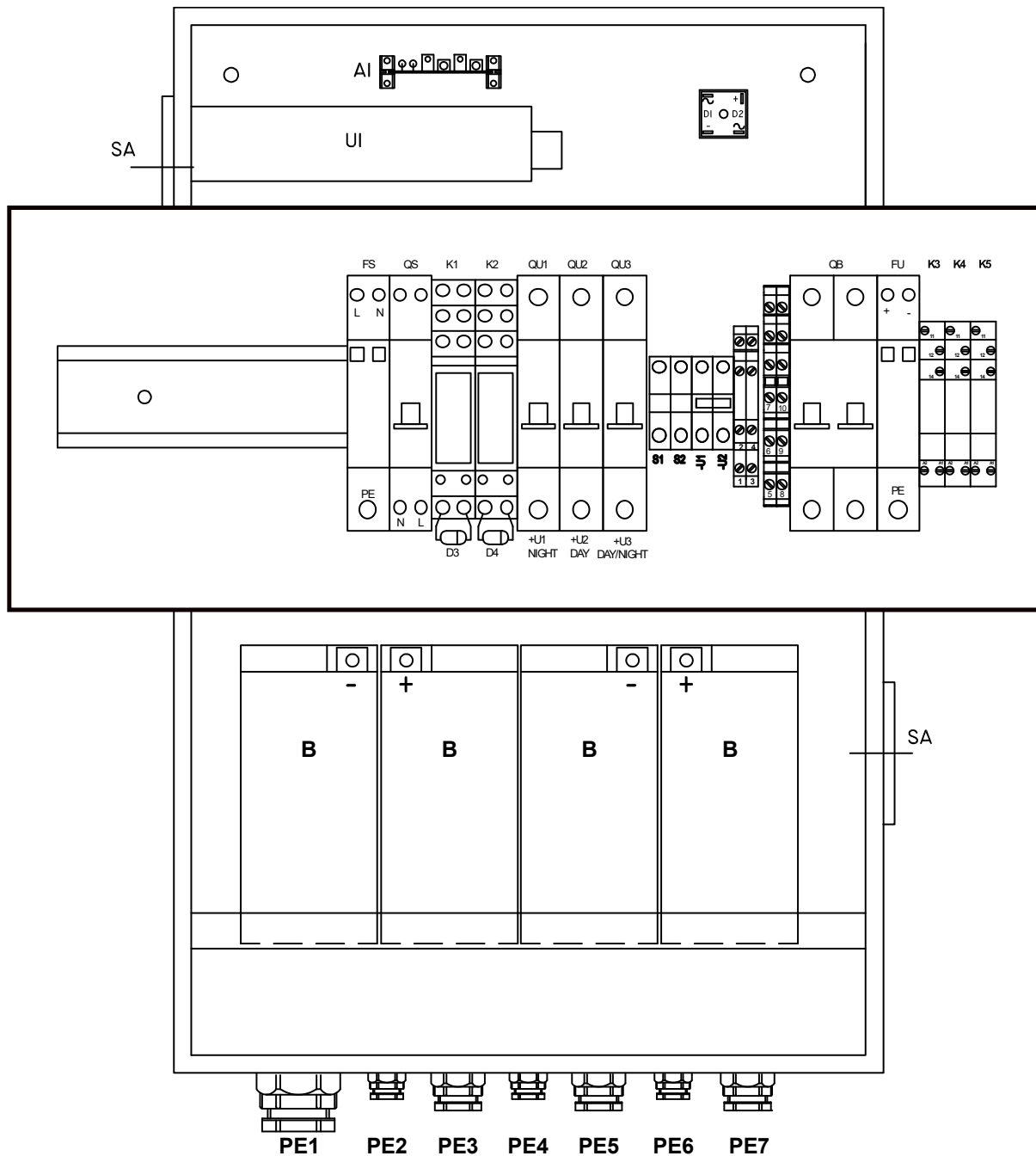

OBSTA  
 3, impasse de la blanchisserie  
 51052 Reims CEDEX – France

This document is the property of OBSTA. It may not be reproduced or communicated to third parties without the written permission of OBSTA

Reference	Designation	Qty
<b>PE</b>	Grounding bar	1
<b>UI</b>	HRP300-48	1
<b>A1</b>	RVU card 1521-3	1
<b>B</b>	12V - 18Ah lead crystal battery [ <b>228435</b> ]	4
<b>D1-D2</b>	Bridge rectifier	1
<b>FS</b>	DS215-230/G – surge protection	1
<b>FU</b>	DS230-48DC - surge protection	1
<b>D3-D4</b>	Diode	2
<b>K1-K2</b>	48V relay	2
<b>QU1</b>	Circuit breaker 1P C4	1
<b>QU2</b>	Circuit breaker 1P C10	1
<b>QU3</b>	Circuit breaker 1P C10	1
<b>QB</b>	Circuit breaker 2P C10	1
<b>QS</b>	Circuit breaker 2P C6	1
<b>X1-X2-X3</b>	Terminal block ZS6	3
<b>U1-U2</b>	Terminal block ZS16	2
<b>S1-S2</b>	Terminal block ZS16	2
<b>BA</b>	Stop blocks BAM3	2
<b>PE1-PE4-PE5</b>	Cable gland PG11	3
<b>PE3</b>	Cable gland PG13	1
<b>PE2</b>	Cable gland PG21	1
<b>SA</b>	Square ventilation grid 100x100	2
-	Cabinet	1
-	DIN rail	1
-	4x10 rivet pop	8
-	ICAO label 57x27	1

### 4.5. Power supply specifications

Meanwell – HRP300-48:

MODEL	HRP-300-3.3	HRP-300-5	HRP-300-7.5	HRP-300-12	HRP-300-15	HRP-300-24	HRP-300-36	HRP-300-48	
OUTPUT	DC VOLTAGE	3.3V	5V	7.5V	12V	15V	24V	36V	48V
	RATED CURRENT	60A	60A	40A	27A	22A	14A	9A	7A
	CURRENT RANGE	0 ~ 60A	0 ~ 60A	0 ~ 40A	0 ~ 27A	0 ~ 22A	0 ~ 14A	0 ~ 9A	0 ~ 7A
	RATED POWER	198W	300W	300W	324W	330W	336W	324W	336W
	RIPPLE & NOISE (max.) Note.2	80mVp-p	90mVp-p	100mVp-p	120mVp-p	150mVp-p	150mVp-p	250mVp-p	250mVp-p
	VOLTAGE ADJ. RANGE	2.8 ~ 3.8V	4.3 ~ 5.8V	6.8 ~ 9V	10.2 ~ 13.8V	13.5 ~ 18V	21.6 ~ 28.8V	28.8 ~ 39.6V	40.8 ~ 55.2V
	VOLTAGE TOLERANCE Note.3	±2.5%	±2.0%	±2.0%	±1.0%	±1.0%	±1.0%	±1.0%	±1.0%
	LINE REGULATION	±0.5%	±0.5%	±0.5%	±0.3%	±0.3%	±0.2%	±0.2%	±0.2%
	LOAD REGULATION	±1.0%	±1.0%	±1.0%	±0.5%	±0.5%	±0.5%	±0.5%	±0.5%
SETUP, RISE TIME	1000ms, 50ms/230VAC		2500ms, 50ms/115VAC at full load						
HOLD UP TIME (Typ.)	16ms/230VAC		16ms/115VAC at full load						
INPUT	VOLTAGE RANGE Note.5	85 ~ 264VAC		120 ~ 370VDC					
	FREQUENCY RANGE	47 ~ 63Hz							
	POWER FACTOR (Typ.)	PF>0.95/230VAC		PF>0.99/115VAC at full load					
	EFFICIENCY (Typ.)	80%	82%	86%	88%	88%	87%	88%	89%
	AC CURRENT (Typ.)	3.5A/115VAC		1.8A/230VAC					
	INRUSH CURRENT (Typ.)	35A/115VAC		70A/230VAC					
	LEAKAGE CURRENT	<1.2mA / 240VAC							
PROTECTION	OVERLOAD	105 ~ 135% rated output power Protection type : Constant current limiting, recovers automatically after fault condition is removed							
	OVER VOLTAGE	3.96 ~ 4.62V	6 ~ 7V	9.4 ~ 10.9V	14.4 ~ 16.8V	18.8 ~ 21.8V	30 ~ 34.8V	41.4 ~ 48.6V	57.6 ~ 67.2V
	OVER TEMPERATURE	Shut down o/p voltage, recovers automatically after temperature goes down Protection type : Shut down o/p voltage, re-power on to recover							
FUNCTION	DC OK SIGNAL	PSU turns on : 3.3 ~ 5.6V ; PSU turns off : 0 ~ 1V							
	FAN CONTROL (Typ.)	Load 35±15% or RTH2≥50°C Fan on							
ENVIRONMENT	WORKING TEMP.	-40 ~ +70°C (Refer to "Derating Curve")							
	WORKING HUMIDITY	20 ~ 90% RH non-condensing							
	STORAGE TEMP., HUMIDITY	-40 ~ +85°C, 10 ~ 95% RH							
	TEMP. COEFFICIENT	±0.03%/°C (0 ~ 50°C)							
	VIBRATION	10 ~ 500Hz, 5G 10min./1cycle, 60min. each along X, Y, Z axes							
SAFETY & EMC (Note 4)	SAFETY STANDARDS	UL62368-1, TUV BS EN/EN62368-1, EAC TP TC 004, AS/NZS 62368.1 approved							
	WITHSTAND VOLTAGE	I/P-O/P:3KVAC I/P-FG:2KVAC O/P-FG:0.5KVAC							
	ISOLATION RESISTANCE	I/P-O/P, I/P-FG, O/P-FG:100M Ohms / 500VDC / 25°C / 70% RH							
	EMC EMISSION	Compliance to BS EN/EN55032 (CISPR32) Class B, BS EN/EN61000-3-2,-3, EAC TP TC 020							
	EMC IMMUNITY	Compliance to BS EN/EN61000-4-2,3,4,5,6,8,11,BS EN/EN55035,BS EN/EN61000-6-2,heavy industry level,EAC TP TC 020							
OTHERS	MTBF	1487.1K hrs min. Telcordia SR-332 (Bellcore) ; 200.4K hrs min. MIL-HDBK-217F (25°C)							
	DIMENSION	199*105*41mm (L*W*H)							
	PACKING	0.95Kg;15pcs/15.3Kg/0.79CUFT							
NOTE	<p>1. All parameters NOT specially mentioned are measured at 230VAC input, rated load and 25°C of ambient temperature.</p> <p>2. Ripple &amp; noise are measured at 20MHz of bandwidth by using a 12" twisted pair-wire terminated with a 0.1 μF &amp; 47 μF parallel capacitor.</p> <p>3. Tolerance : includes set up tolerance, line regulation and load regulation.</p> <p>4. The power supply is considered a component which will be installed into a final equipment. All the EMC tests are been executed by mounting the unit on a 360mm*360mm metal plate with 1mm of thickness. The final equipment must be re-confirmed that it still meets EMC directives. For guidance on how to perform these EMC tests, please refer to "EMI testing of component power supplies." (as available on <a href="https://www.meanwell.com/Upload/PDF/EMI_statement_en.pdf">https://www.meanwell.com/Upload/PDF/EMI_statement_en.pdf</a>)</p> <p>5. Derating may be needed under low input voltages. Please check the derating curve for more details.</p> <p>6. The ambient temperature derating of 3.5°C/1000m with fanless models and of 5°C/1000m with fan models for operating altitude higher than 2000m(6500ft).</p> <p>※ Product Liability Disclaimer : For detailed information, please refer to <a href="https://www.meanwell.com/serviceDisclaimer.aspx">https://www.meanwell.com/serviceDisclaimer.aspx</a></p>								

OBSTA

3, impasse de la blanchisserie  
51052 Reims CEDEX – France

This document is the property of OBSTA. It may not be reproduced or communicated to third parties without the written permission of OBSTA

## 5. Wiring

### 5.1. Internal wiring

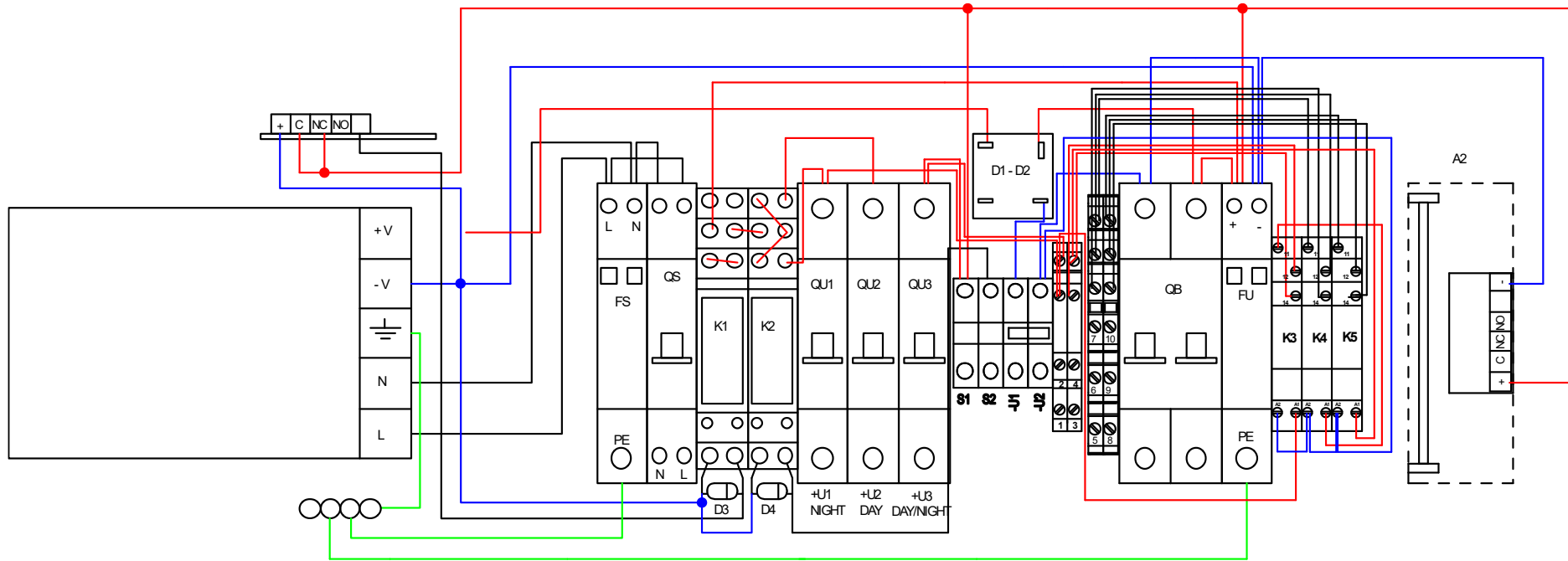

## 5.2. Battery

**Storage:** Always store batteries fully charged. If a battery is stored for a long period, it will top up every 6 months. Store batteries in a cool, dry place.

**Temperature:** Keep batteries at a temperature between -15°C and +50°C during charging and discharging. Avoid installing batteries near heat sources.

**Recommendation:** Avoid short-circuiting terminals. NEVER expose to flame. Avoid contact with any type of oil, solvent, petroleum-based detergent or ammonia solution, as this may damage the batteries.

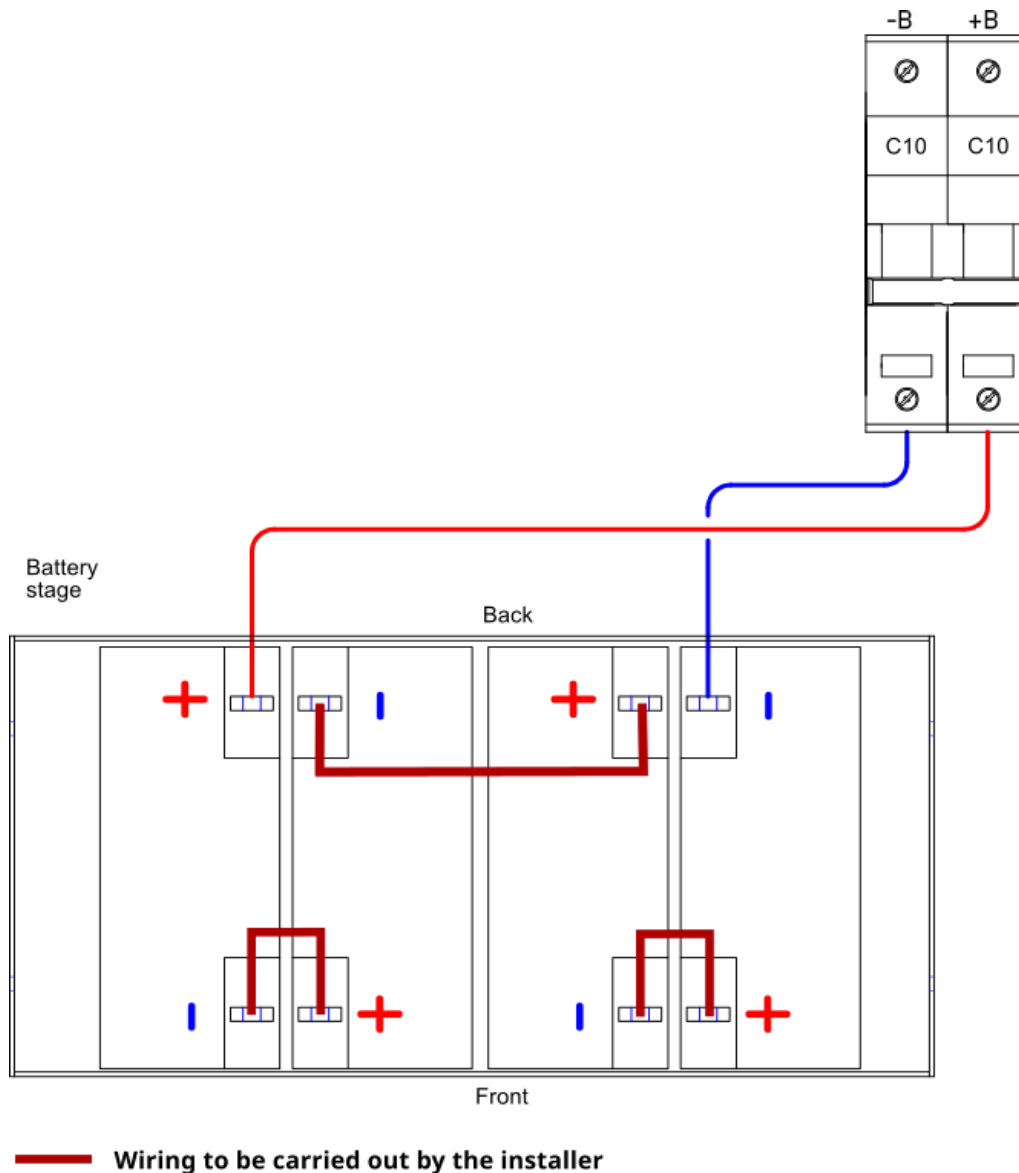

### 5.3. Photocell (option)

The photoelectric cell (P/N 100757) must be connected to terminals S1, S2, and -U1.

Depending on the type of lighting installed, the photocell controls the activation of the lights: low and medium intensity lights at only or during the day only (red wire).

#### Connection with twilight sensor

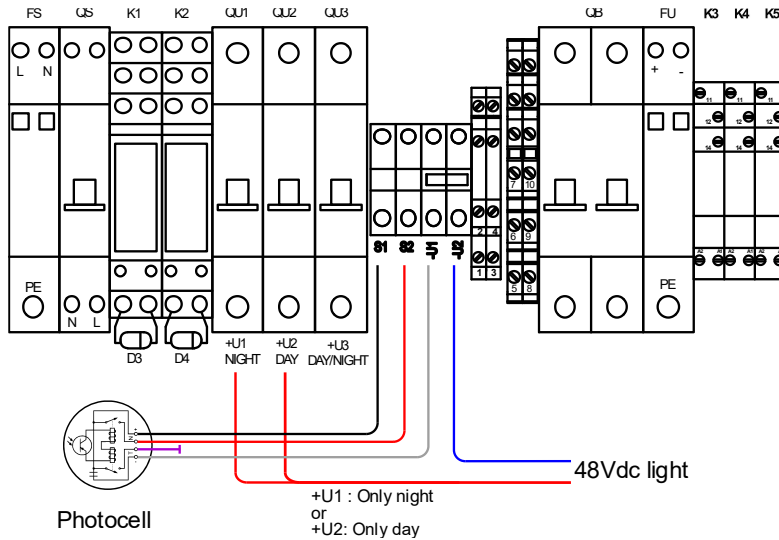

#### Connection without twilight sensor

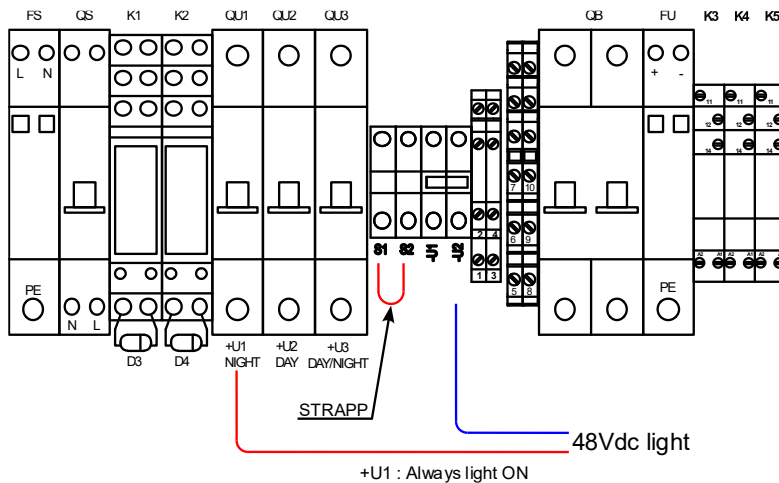

OBSTA  
3, impasse de la blanchisserie  
51052 Reims CEDEX – France



## 6. Maintenance

### 6.1. Annual visit

Test	Frequency	Preventive action	Risk
<b>Wiring</b>	Annual	Visual control Tightening cable glands Tightening PCB wires	Water infiltration Poor circuit Cable degradation
<b>Waterproof</b>	Annual	Visual verification Search for the water leak	Water infiltration Short circuit Lamp in default mode (or light off)
<b>Clamping</b>	Annual	Checking tightness	Cabinet falling
<b>Aspect (rust, dust...)</b>	Annual	Exterior cleaning	Malfunction

### 6.2. Spare part

HRP-300-48	<b>113956-U1</b>
kit Batterie 18 Ah + cosse	<b>113956-BAT</b>
Relay K1-K2	<b>113956-RELAY</b>
Pont de diode	<b>113956-DB</b>
Carte RVU 1521-3	<b>113956-RVU</b>
Carte Alarme tension basse RV 1521-1	<b>113956-RV</b>
Parafoudre DC - <b>DS230-48VDC</b>	<b>390401</b>
Parafoudre AC - <b>DS215-230/G</b>	<b>451721</b>

## 7. Appendix

### 7.1. Battery specifications



#### DISCHARGE CURRENT AND END VOLTAGE

Discharge current (A)	End voltage (V)
0.05C or below or Intermittent discharge	11.4
0.05C of current close to it	11.1
0.1C of current close to it	10.8
0.2C of current close to it	10.5
From 0.2C to 0.5C	10.2
From 0.5C to 1C	9.6
From 1C to 3C	9.0
Current in excess of 3C	7.8

#### CHARGE vs TEMPERATURE

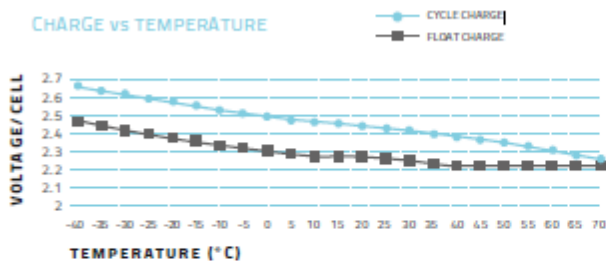

#### CHARGE vs TEMPERATURE CHART

temperature	-40	-35	-30	-25	-20	-15	-10	-5	0	5	10	15	20	25	30	35	40	45	50	55	60	65	70
Cycle Charge	2.66	2.64	2.62	2.60	2.58	2.56	2.54	2.52	2.50	2.48	2.47	2.47	2.45	2.45	2.43	2.41	2.39	2.37	2.35	2.33	2.31	2.29	2.27
Float Charge (voltage/cell)	2.46	2.44	2.42	2.40	2.38	2.36	2.34	2.32	2.31	2.30	2.29	2.29	2.29	2.27	2.26	2.24	2.23	2.23	2.23	2.23	2.23	2.23	2.23

#### CONSTANT CURRENT DISCHARGE CHARACTERISTICS: UNITS AMPERES (25°C)

End Voltage per cell	5min	15min	30min	45min	1h	2h	3h	4h	5h	6h	8h	10h	12h	20h	24h
1.60V	66.05	34.96	21.12	15.40	12.40	7.11	5.16	4.05	3.45	2.93	2.24	1.86	1.56	1.02	0.83
1.67V	61.39	33.81	20.81	15.29	12.38	7.08	5.07	4.03	3.40	2.91	2.23	1.84	1.56	1.01	0.83
1.70V	60.76	33.29	20.60	15.09	12.28	7.01	5.04	4.01	3.35	2.88	2.23	1.84	1.56	1.01	0.83
1.75V	55.66	32.25	20.39	14.98	12.07	6.88	5.01	3.96	3.32	2.86	2.22	1.82	1.55	1.01	0.83
1.80V	49.94	30.17	19.56	14.57	11.76	6.77	4.99	3.94	3.28	2.83	2.21	1.80	1.54	0.97	0.82
1.83V	47.74	27.68	19.25	14.05	11.24	6.71	4.80	3.78	3.20	2.73	2.16	1.73	1.48	0.96	0.81
1.85V	44.73	26.84	18.00	13.53	10.92	6.44	4.67	3.72	3.12	2.64	2.13	1.71	1.46	0.95	0.81

#### DISCHARGE DATA WITH CONSTANT POWER UNITS: WATTS PER CELL (25°C)

End Voltage per cell	5min	15min	30min	45min	1h	2h	3h	4h	5h	6h	8h	10h	12h	20h	24h
1.60V	110.38	61.38	39.53	28.82	23.18	13.42	9.81	7.77	6.56	5.64	4.35	3.60	3.03	2.02	1.65
1.67V	105.07	60.44	37.93	28.61	23.20	13.42	9.69	7.76	6.56	5.63	4.35	3.59	3.03	2.02	1.65
1.70V	104.45	60.03	37.92	28.61	22.99	13.32	9.66	7.73	6.46	5.59	4.32	3.56	3.00	2.01	1.65
1.75V	97.27	59.30	37.96	28.61	22.89	13.21	9.64	7.72	6.44	5.54	4.30	3.53	3.00	2.01	1.64
1.80V	89.26	56.28	37.14	28.09	22.78	13.21	9.63	7.70	6.40	5.54	4.29	3.52	3.00	1.96	1.64
1.83V	86.14	51.70	36.83	27.26	21.85	13.11	9.36	7.44	6.33	5.37	4.29	3.41	2.94	1.94	1.63
1.85V	79.79	50.56	34.23	26.22	21.22	12.80	9.10	7.34	6.15	5.26	4.12	3.38	2.89	1.91	1.62

#### SPECIFICATION

Nominal Voltage	12V		
Rated Capacity (10 hour rate)	18 AH		
Dimension	Total Height (top of terminal)	170 mm	6.69"
	Height	170 mm	6.69"
	Length	181 mm	7.13
	Width	76 mm	2.99"
Weight	Approximately 6.2 kg /13.66 lbs		
Capacity	120 hour rate (200mA)	22 AH	
	20 hour rate (1.0A)	20 AH	
	10 hour rate (1.8A)	18 AH	
Internal Resistance	Fully charged Battery (25°C)	12mΩ	
	Self-Discharge 25°C	Capacity after 3 month storage	95%
		Capacity after 6 month storage	85%
		Capacity after 12 month storage	80%
Max Discharge Current 25°C	180A (5S)		
Terminal	Standard	F5	
	Optional		
Charging (Constant Voltage)	Cycle	Initial Charging Current 5.4A	
		14.7V/ (25°C)	
	Float	13.6V/ (25°C)	

OBSTA

3, impasse de la blanchisserie  
51052 Reims CEDEX – France

This document is the property of OBSTA. It may not be reproduced or communicated to third parties without the written permission of OBSTA

6-CNFJ-18 12V/18Ah

CYCLE CHARGE CHARACTERISTIC (25°C)

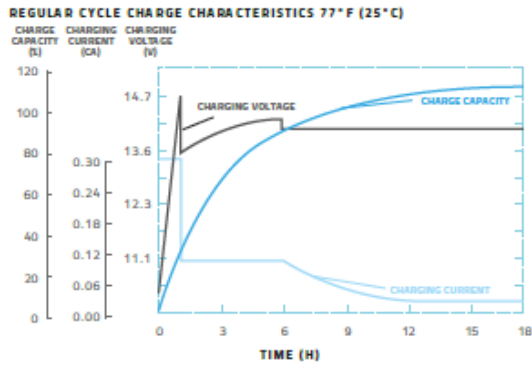

FLOATING CHARGE CHARACTERISTIC (25°C)

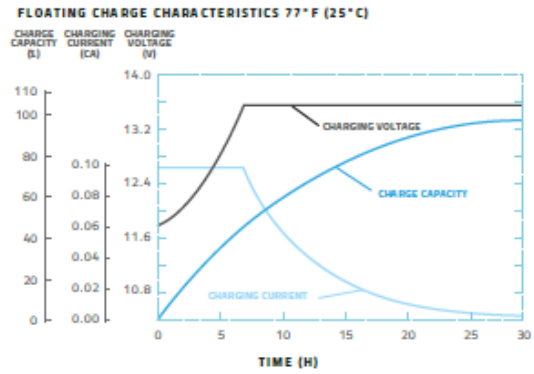

CYCLE LIFE CURVE GRAPH

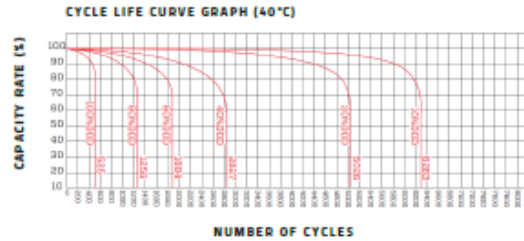
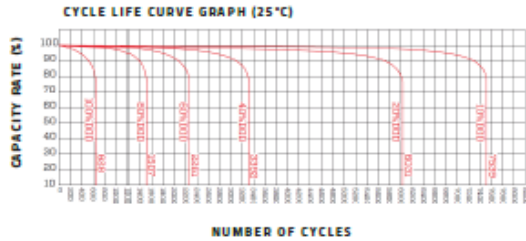

TEMPERATURE & FLOAT SERVICE LIFE

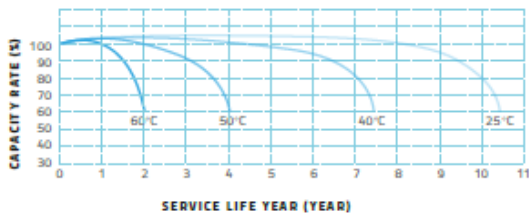

FLOAT SERVICE LIFE CURVE GRAPH

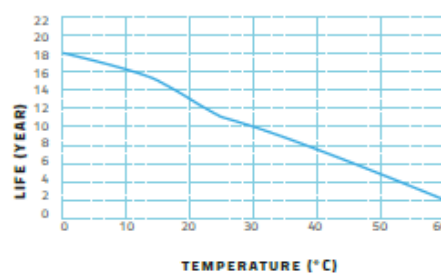

TEMPERATURE & DISCHARGE CAPACITY

