

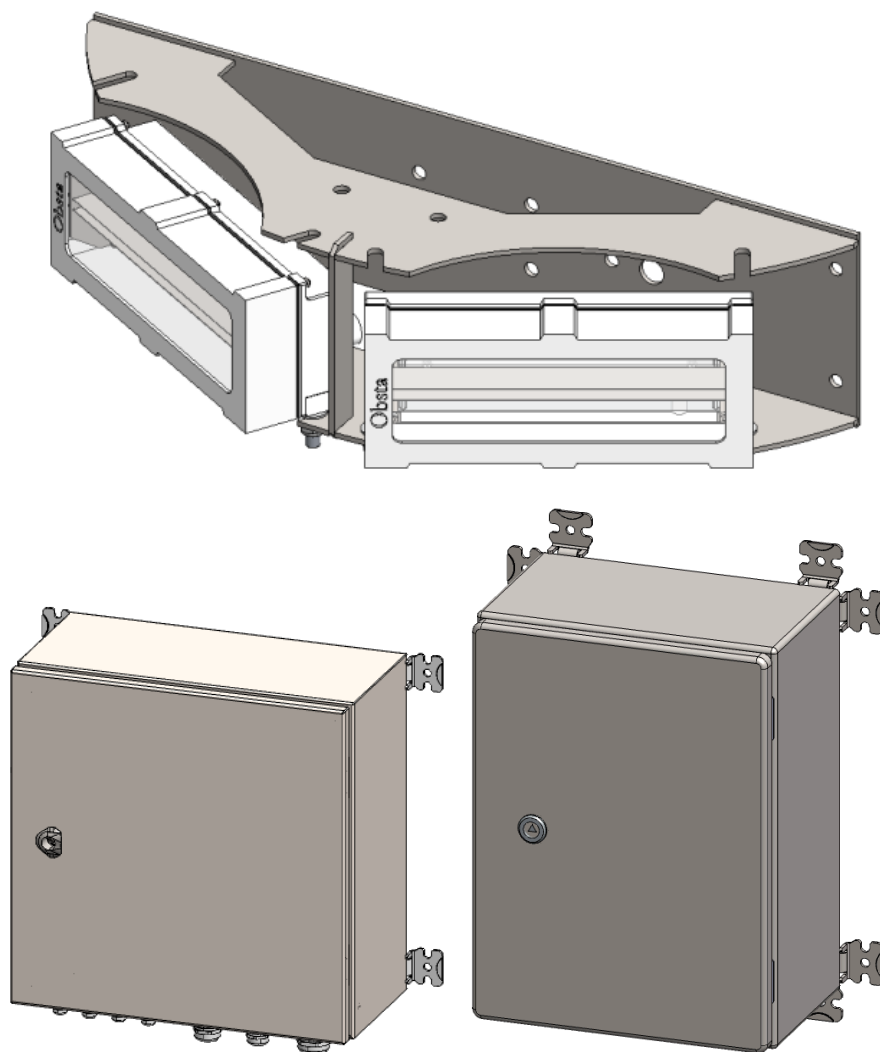

RELIABILITY IN OBSTRUCTION LIGHTING  
BALISAGE AÉRIEN



OFI 120 // 240Vac  
OFP 120 // 240 Vac



Obsta  
3, impasse de la blanchisserie  
51052 Reims CEDEX - FRANCE

<b>1. Product name and part number.....</b>	<b>3</b>
<b>2. Be careful.....</b>	<b>5</b>
<b>3. Warranty.....</b>	<b>6</b>
<b>4. General information.....</b>	<b>7</b>
4.1 Scope.....	7
4.2 General description.....	7
<b>5. FAA version.....</b>	<b>8</b>
6. Power supply cabinet.....	9
7. Power unit.....	12
7.2. Bill of materials.....	13
7.3 Cards inside the power supply cabinet.....	14
7.3.1 1 block interconnection card (O-PCB-00037-OFP).....	14
7.3.2 Command card (O-PCB-00012).....	15
7.3.3 Power card (O-PCB-00015-OFP).....	20
7.3.4 Alimentation card (O-PCB-00038-OFP).....	20
7.4 Internal Wiring.....	21
<b>8. Operation and configuration.....</b>	<b>25</b>
8.1 Terminal connexion.....	25
8.2 Switches configuration.....	26
8.2.1 SW1-Configuration.....	26
8.2.2 SW2-GPS.....	26
8.2.3 SW3 - Control.....	27
8.2.4 SW4 - Mode.....	27
8.3 Default.....	28
8.3.1 Operation led.....	28
8.3.2 Power card led.....	29
8.3.3 Alarm.....	29
<b>9. Installation.....</b>	<b>30</b>
9.1 Unpacking.....	30
9.2 Mounting and preparation.....	30
9.3 Wiring overview.....	32
<b>10. Maintenance.....</b>	<b>34</b>
10.1 Annual visit.....	34
10.2 Spare part.....	34
<b>11. Technical specifications.....</b>	<b>35</b>
11.1 Light output.....	35
11.2 Electrical input for 48Vdc.....	35
11.3 Electrical input for 120/ 240 Vac.....	36
11.4 Operating environments.....	36
<b>12. Drawing.....</b>	<b>37</b>
<b>13. Typical wiring.....</b>	<b>38</b>

# 1. Product name and part number

Description	Norm	Power supply	Article code (P/N)	QR code
OFI120-RW-48/240-U 	ICAO type A, B and C FAA L-864/L-865 ETL certified	110-240 Vac $\pm 10\%$	113758UA	

## 2. Be careful



- Do not proceed with any maintenance job when the product is under operation.
- Power supply must be shut down when opening the flash-head or the cabinet.
- Installation must be performed only by an electrically skilled operator and National electrical installation rules must be respected.
- Always wear appropriate Personal Protective Equipment (PPE) when installing, maintaining or servicing the system.
- Any installation or maintenance operation performed at height must be carried out in strict compliance with fall-protection procedures.
- Do not look directly at the projector while it is in operation : Led projectors produce brilliant flashes of lights which can result in temporary or permanent eye damage.
- OBSTA products may be affected by ESD, use state of the art precaution before manipulation.
- Unless otherwise specified, all cables must be shielded and the shielding must be connected to ground.
- All cables connected to PCBs and terminal blocks must be equipped with a cable connector to prevent false contacts when connecting devices.



### 3. Warranty

OBSTA warrants the equipment described in the instruction manual and sold to purchasers to be free from defects in material and workmanship at the time of shipment. OBSTA's liability under this warranty being limited to repairing or replacing, at OBSTA's option, items which are returned to it prepaid within twenty four (24) months from shipment to the original Purchaser, or twelve months from commissioning, and found, to OBSTA's satisfaction, to have been defective. In no event shall OBSTA be liable for consequential damages. NO PRODUCT IS WARRANTED AS BEING FIT FOR A PARTICULAR PURPOSE AND THERE IS NO WARRANTY OF MERCHANTABILITY.

This warranty applies only if: (I) the items are used solely under the operating conditions and in the manner recommended in OBSTA's instruction manual, specifications, or other literature; (II) the items have not been misused or abused in any manner or repairs attempted thereon; (III) written notice of the failure within the warranty period is forwarded to OBSTA and the directions received for properly identifying items returned under warranty are followed; and (IV) such return notice authorizes OBSTA to examine and disassemble returned products to the extent OBSTA deems necessary to ascertain the cause of failure. The warranties stated herein are exclusive.

THERE ARE NO OTHER WARRANTIES, EITHER EXPRESSED OR IMPLIED, BEYOND THOSE SET FORTH HEREIN, and OBSTA does not assume, nor does OBSTA authorize anyone else to assume for it, any other obligation or liability in connection with the sale or use of said products. OBSTA's liability on any claim of any kind, including negligence, for loss or damages arising out of or connected with the manufacture, sale, delivery, repair or use of any equipment or services provided by OBSTA shall in no case exceed the price allocable to the item or service or part thereof which gives rise to the claim.

The integrity and reliability of OBSTA aviation obstruction lighting systems is dependent on the use of OBSTA parts and components. To ensure the optimum performance and reliability of your OBSTA system, it is strongly advised that only components and modules manufactured by OBSTA be used.

## 4. General information

### 4.1 Scope

This manual provides information about the installation, operation and maintenance of the OBSTAFLASH led medium and high intensity obstruction lightning systems manufactured by OBSTA. The lightning systems described in this manual are intensity type A, B, C and/or FAA 150-5345-43J type L-865/L-864/L-866/L-856/L-857 obstruction light.

The OBSTAFLASH is manufactured to comply with ICAO annex 14 chapter 6 and Federal Aviation Administration Advisory Circular 150/5345-43J

### 4.2 General description

The spotlight is a subset of the Obstaflash LED light heads. These lights are designed to mark out aerial obstacles such as wind turbines, electricity pylons or telecommunications towers.

The projector is responsible for the light output of the light head. Thanks to its integrated lens, it focuses the light produced by the leds to comply with current aerial beaconing standards. The projectors are systematically combined with an electronic control system in a control box (OBSTAFLASH P/N-113797U cabinet).

OFI, OFH and OFP systems are combinations of several projectors that can be used in different ways depending on the customer's requirements.

For example:

- OFI 120 is 3 OFP120 + 1 Power unit (+1 power supply for 240 version)
- OFP 120 and 180 is 2 or 3 differently oriented spotlights
- OFH 120 and 180 is a combination of several OFP stages

Depending on the application, the OBSTAFLASH can be mounted on a range of brackets to provide 120°, 180° or 360° illumination. Models operating on 110-240Vac are fitted with an additional power supply unit.

## 5. FAA version

The OBSTAFLASH lighting system L-865/L-864 is a medium intensity system manufactured to comply with Federal Aviation Administration advisory circular 150/5345-43J.

To comply with standard L-865/L-864, FAA-certified OFPs and OFIs use specific projectors (P/N 113761UIR).

The list of OFI (OFP + power supply unit + power supply (110/240 Vac version) is as follows:

- OFI120-RW-48/240-U (P/N 113758UA)

## 6. Power supply cabinet

Les dimensions sont en mm  
All dimensions are in mm

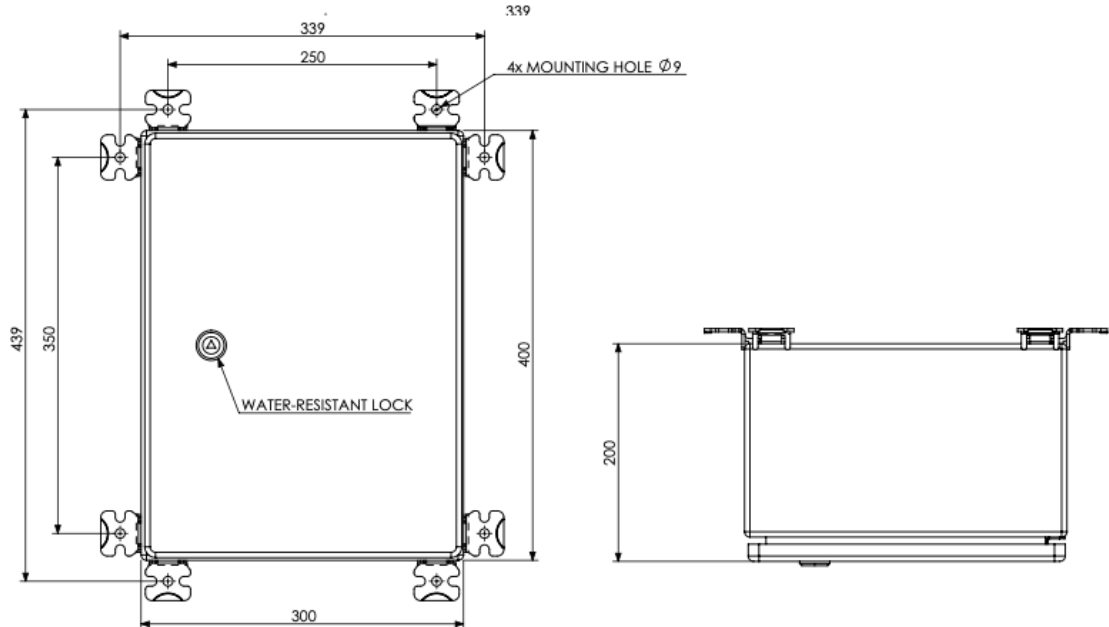

Functionality and features of the cabinet (only for 240Vac version) **P/N 113797U:**

- “Weather tight” stainless steel 316L power cabinet enclosure
- Test button for day and night
- Alarm dry contact NC and NO
- Master/slave configuration for multiple lights synchronisation
- Can be used with photocell 48Vdc
- In option low intensity lights NAVILITE 48Vdc or L-810 (F) NAVILITE-IR-FAA-120-240V or night only operation
- Wireless GPS synchronisation (P/N-113746)

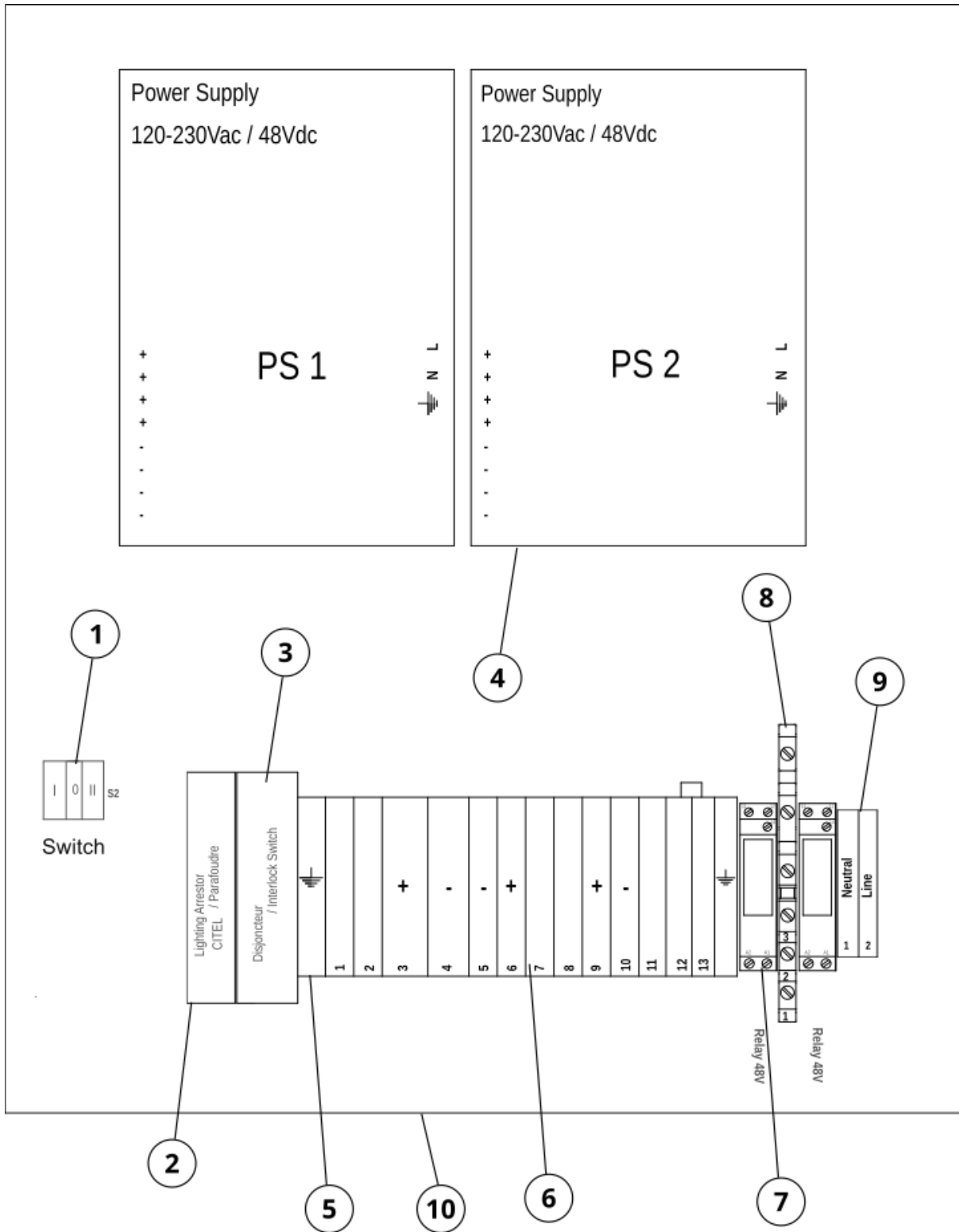

N°	Designation	Spare part (if available)	Qty
1	Security/Day/night test switch	113743	1
2	CITEL DS215-230/G	451721	1
3	16A circuit breaker		1
4	SP600 48Vdc 12.5 A power supply	113742	2
5	Ground terminal		2
6	Terminal block		13
7	48Vdc relay		2
8	Connection block UT 2.5-3L		1
9	Connection block 2.5mm <sup>2</sup>		2
10	300x400x3200 inox cabinet		1

## 7. Power unit

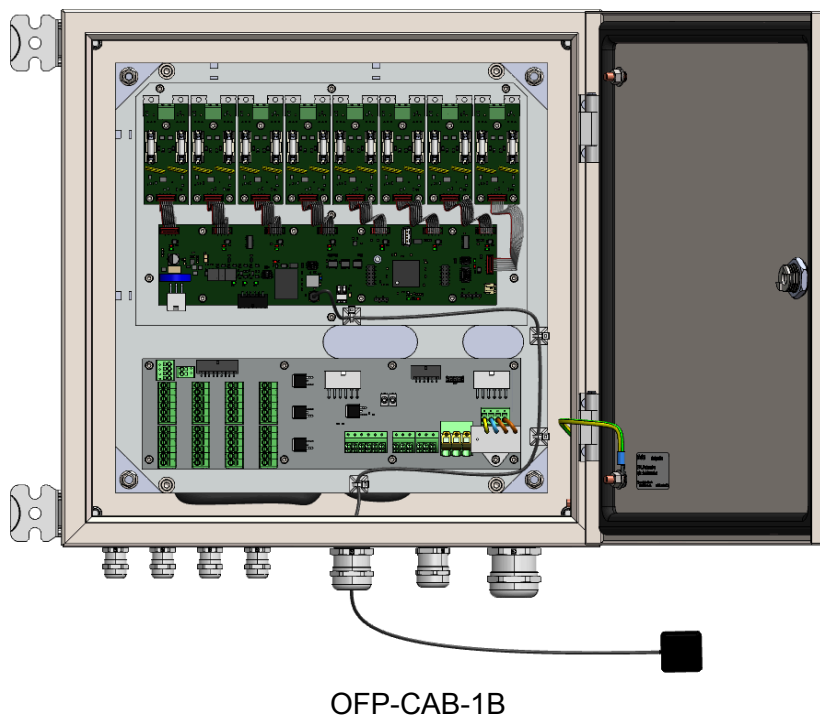

The OBSTA power unit cabinet is a stainless steel or painted steel cabinet whose main function is to power and control OBSTA OFP120 and/or OFP180 lamps. With one controller (one block), you can connect 6 projector.

## 7.2. Bill of materials

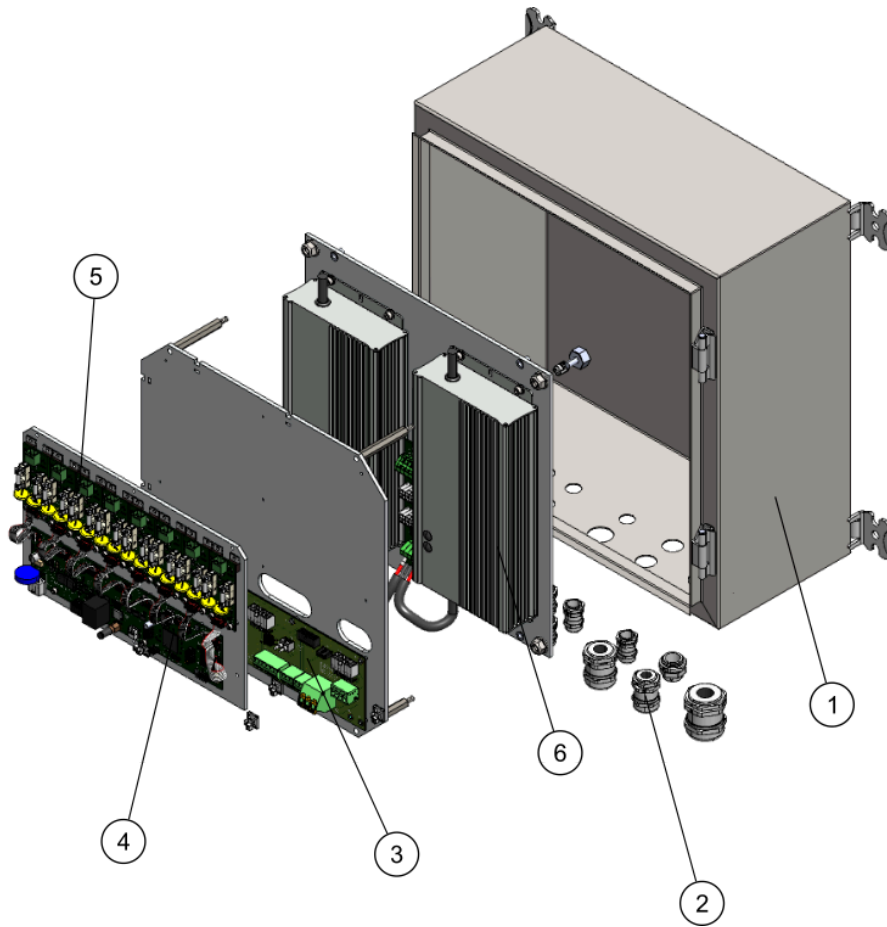

	Designation	Spare part [P/N]
<b>1</b>	Cabinet	<b>228415</b>
<b>2</b>	Cable gland* (M16, M20, M25, M32, M40) *see 6.2 for detail	
<b>3</b>	Interconnection card	<b>770334</b>
<b>4</b>	Command card	<b>113744B</b>
<b>5</b>	Power card	<b>113741B</b>
<b>6</b>	Power supply and alimentation card (only for 240 Vac version)	<b>228325</b>

## 7.3 Cards inside the power supply cabinet

### 7.3.1 1 block interconnection card (*O-PCB-00037-OFP*)

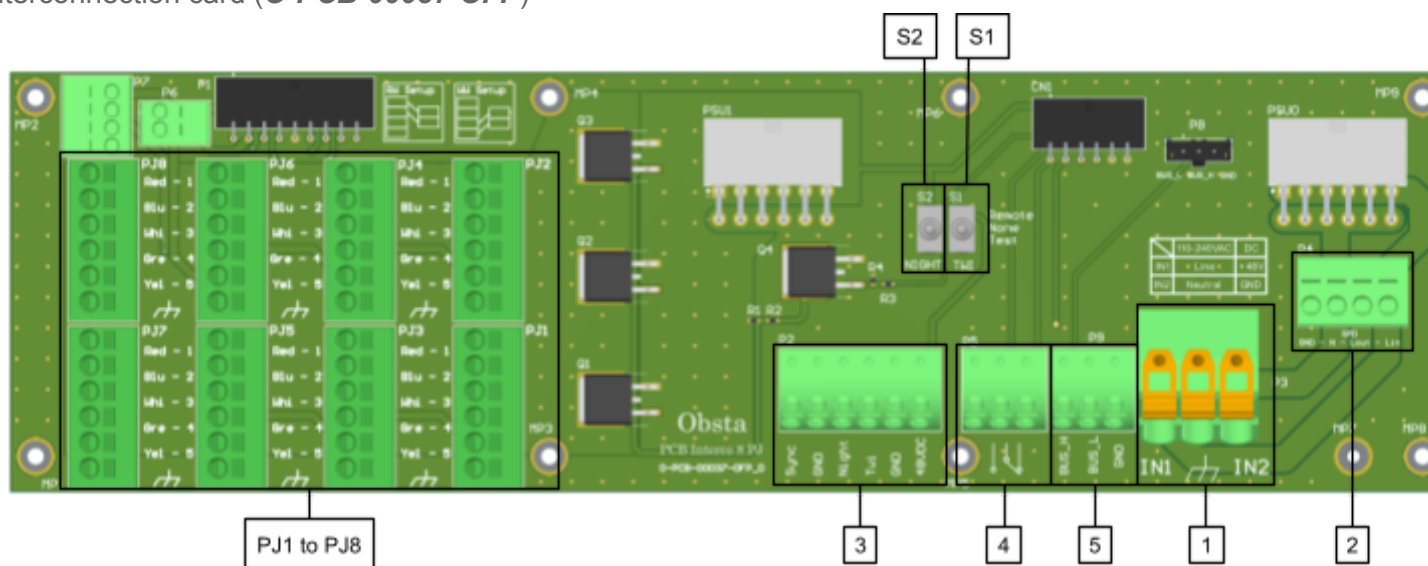

- PJ1 to PJ8/ Projector connector must be connected according to the cable color or number. Other harnesses are cabled directly from the factory. Do not modify the cabling without Obsta's direct consent.
- 1/ Power input: +/-/Earth (Vdc) or L/N/Earth (Vac)
- 2/ Surge protection terminal
- 3/ Communication signal for flash and mode (day, night) from photocell signal and top synchro
- 4/ Alarm : NO/ COM/ NC
- 5/ Communication BUS terminal
- S1/ Test switch for twilight. manual force the signal to twilight (Must be always in remote position for normal operation)
- S2/ Test switch for day/night. manual force the signal to day/night (Must be always in remote position for normal operation)

Obsta  
3, impasse de la blanchisserie  
51052 Reims CEDEX - FRANCE

This document is the property of OBSTA. It may not be reproduced or communicated to third parties without the written permission of OBSTA.

## 7.3.2 Command card (O-PCB-00012)

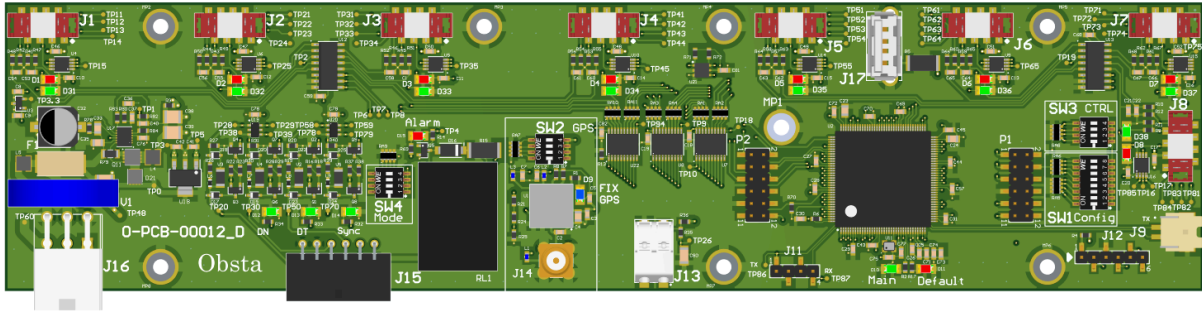

This part is responsible for managing the whole flash head. The embedded microcontroller can analyse input signals (such as GPS, various external signals) and act accordingly.

*\*Detail on next page*

- J1 to J7: Connected to a dedicated power card. Near each connector, a pair of led (Green & Red) is signaling the status of the power card hence the associated projector, see figure 4 below.
- J9: Connected to another command board for internal synchronization (specific).
- J13: Connector for photo resistor application (specific).
- J14: Connector for GPS antenna.
- J16: USB connector used for reprogramming the Card and retrieving event log (don't operate any USB device without Obsta's consent).

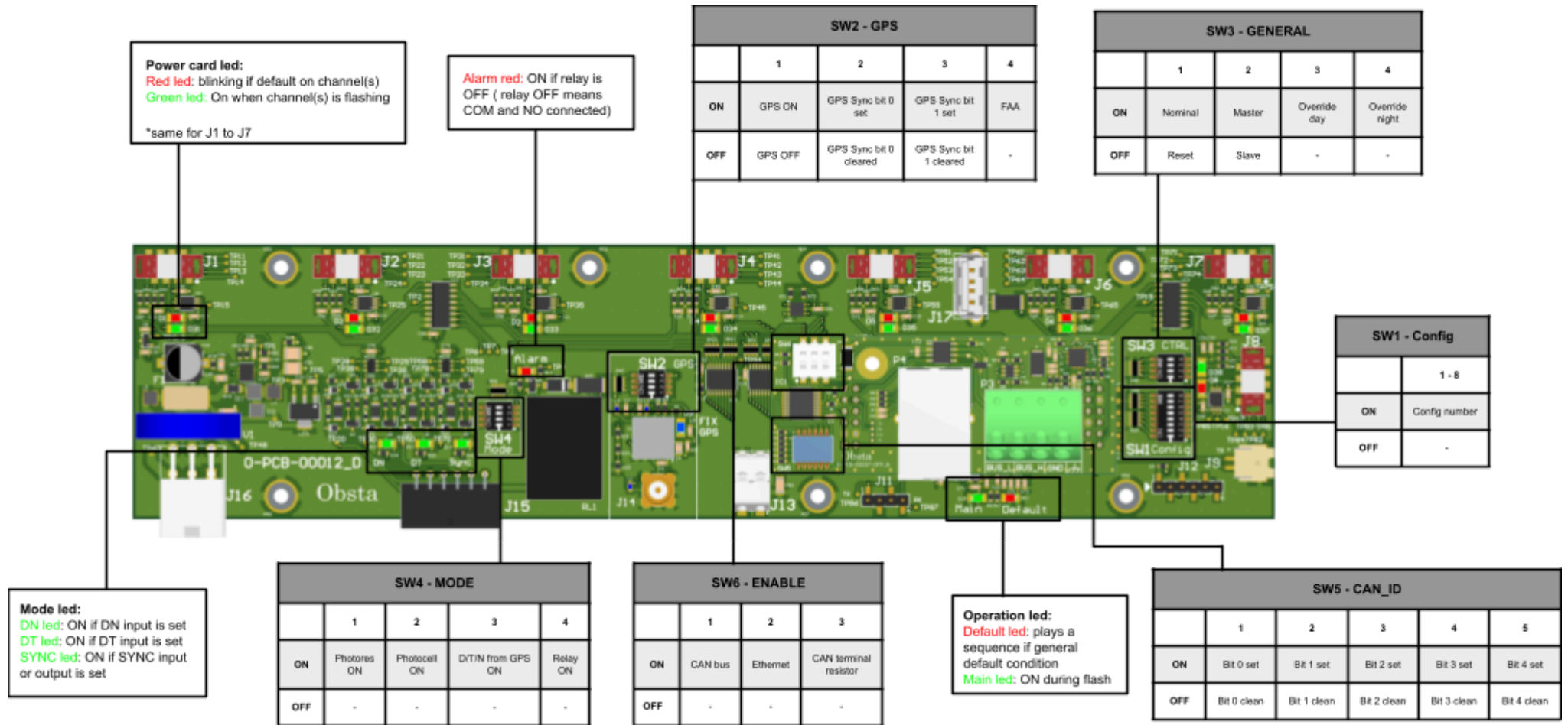

Obsta  
 3, impasse de la blanchisserie  
 51052 Reims CEDEX - FRANCE

## Errors when starting up the card

The following cases appear when the card is started up, when the configuration is incomplete, and prevent the program from running. **All red leds on the power cards:**

- Flash at the same time if the programme is for production and the series number has not been programmed.
- Light up one after the other if Ethernet is enabled but the IP address has not been configured.

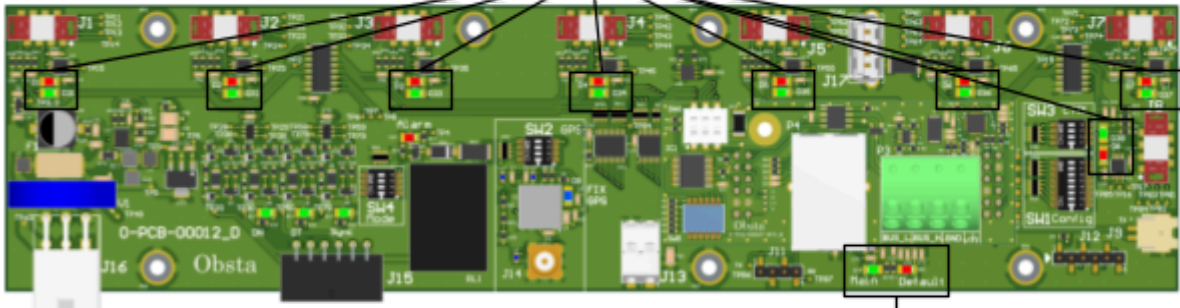

## During a firmware update via USB → IP address configuration

- The copy of the logs onto a USB key went well
- The new software was copied to the card successfully
- The IP configuration was correctly done (• and • alternate 12 times)

### Possible error sequence

- Error mounting the file system
- Error in the format of the `ip.cfg` file
- Empty USB key
- Error opening `Mi.bin` file
- Error while waiting for write access to flash memory
- Error during `MI.bin` file reading (Input/Output error or invalid file size)
- Error decrypting the `MI.bin` file
- Error writing `MI.bin` file to flash memory
- CRC incorrect (this error may be caused by an incorrect encryption key)
- Error during `mi_log.bin` file encryption
- Error when writing the `mi_log.bin` file
- Error when unmounting the file system (this event reported AFTER the USB key has been removed, for 10 sec)
- Error processing USB events: unexpected event

**Operation led:** 2 leds are present to inform about operation status. See default section for more information.

### In Operating conditions

- Power supply voltage problem
- Configuration is invalid
- Default mode activated due to channels errors
- Relay activated due to channels errors
- Slave out of synchronization (no TOP SYNCHRO received)
- GPS out of synchronization
- HIFAA internal communication problem (between the two PCB)
- Day/Twilight/Night mode unchanged (since 48 hours)
- External (CAN or Ethernet) communication problem
- GPS lost synchronization since less than 15 minutes

### During USB firmware update process

- Log retrieval has been processed successfully
- Software update has been processed successfully

In any other case, a specific sequence will be played on Default led, refer to SRS (Software Requirement Specification) for details.

**Power card led:** 7 pairs of 2 led indicators are present to inform about the operation status of each power card (J1 to J7).

- Short circuit
- Full open-circuit
- Full regulation problem
- Full regulation problem
- One channel regulation problem

**Mode led:** 3 leds are present to inform about synchronization and “Mode” information  
*Top sync* blink at each lamp flash in master configuration or at each flash request received from the controller.

*DT:* for twilight mode (depending on switch 4 configuration and model).

*DN:* for night mode (depending on switch 4 configuration and model).

**Switch:** They are present to allow multiple kind of operation:

- SW1: Select the topology and the associated configuration (FPM, Flash frequency, etc...)
- SW2: Set the synchronisation with GPS
- SW3: Control (lamp ON/OFF, master slave ...)
- SW4: Set switch sensor is used for mode change (Day, Twilight, Night)

*For more information about switches see the dedicated section.*

**USB port:** A USB port is available on the PCB (PJ16), allowing to connect a mass storage device and process:

- a firmware update;
- a log retrieval operation
- TCP/IP configuration

**The USB device may not be used without Obsta's consent.**

USB default code (in the following may order):

Error condition	Default led sequence
Error when mounting USB file system.	— · — 1 long, 1 short and 1 long
Error parsing an “ip.cfg” file.	— · · · 2 long and 2 short
USB key is empty, no log file, no firmware, no IP configuration detected.	· 1 sort
Error when opening an “MI.bin” file.	— · 1 short and 1 long
Error waiting for flash memory write access.	— · · 1 long and 2 short
Error when reading “MI.bin” file.	— · · · 1 long and 3 short
Error when decrypting “MI.bin” file.	· — 1 short and 1 long
Error when writing “MI.bin” file to flash memory.	· · — 2 short and 1 long
Incorrect CRC result.	· · · — 3 short and 1 long
Error when encrypting “mi_log.bin” file.	· · 2 short
Error when writing “mi_log.bin” file.	· · · 3 short
Removing the USB key during playback (after a 10sec delay).	— 1 long
Error when processing USB event: unexpected event.	— — 2 long

### 7.3.3 Power card (*O-PCB-00015-0FP*)

The power supply unit includes 8 power cards per block. Those cards regulate the current of 16 led circuits, 2 per PCBa (Depending on the installation) .

The 8 power cards drive the white (or red/IR) led circuits inside each projector.

For white configuration: each card is affected by the associated projector number on the interconnection board. the power cards #1 to #8 are associated to white led circuits inside projectors from left to right (PJ1 → Power card #1, PJ2 → Power card #2 ... PJ8 → Power card #8). One power card for one white projector.

For red configurations: the red and infrared circuits of the projectors are connected in series. Unlike “white” connections, one power card can control several red and/or infrared projectors.

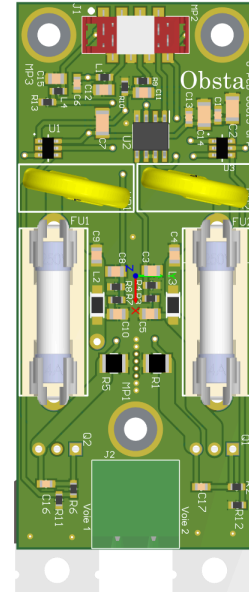

### 7.3.4 Alimentation card (*O-PCB-00038-0FP*)

The alimentation card is used to connect two power supplies (*MEANWELL-HLG-480H-48A*) to the system. It is therefore only used for 240Vac models.

***Do not modify any factory preset or cabling without Obsta consent.***

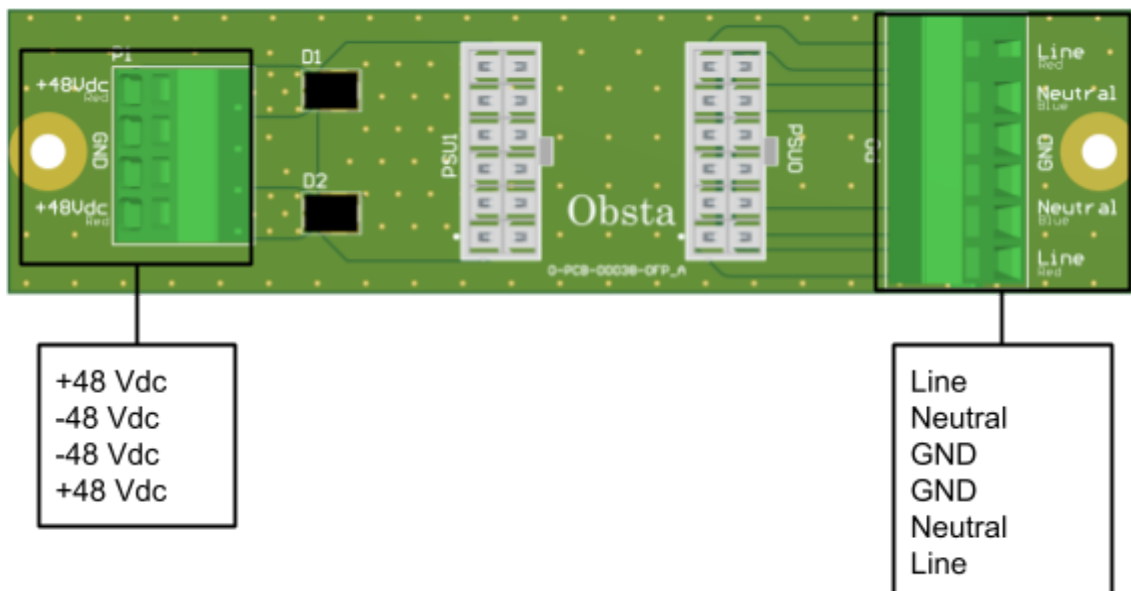

## 7.4 Internal Wiring

All cards are connected by cable harness. There are 4 harnesses in total:

- AC Power harness → From Interconnection to Power Supply card
- DC Power harness → From Interconnection to Power supply card
- Signal Harness → From Interconnection to Command card
- Projector Harness → From Interconnection to Power card (1 to 7)

***All harnesses are installed in the OBSTA factory. If any operation is needed, please contact OBSTA before any intervention. Harness must be manipulated with care, do not pull the harness by the wire. Avoid using tools (Screwdriver) for removing connectors from the card, this could damage the harness or the card.***

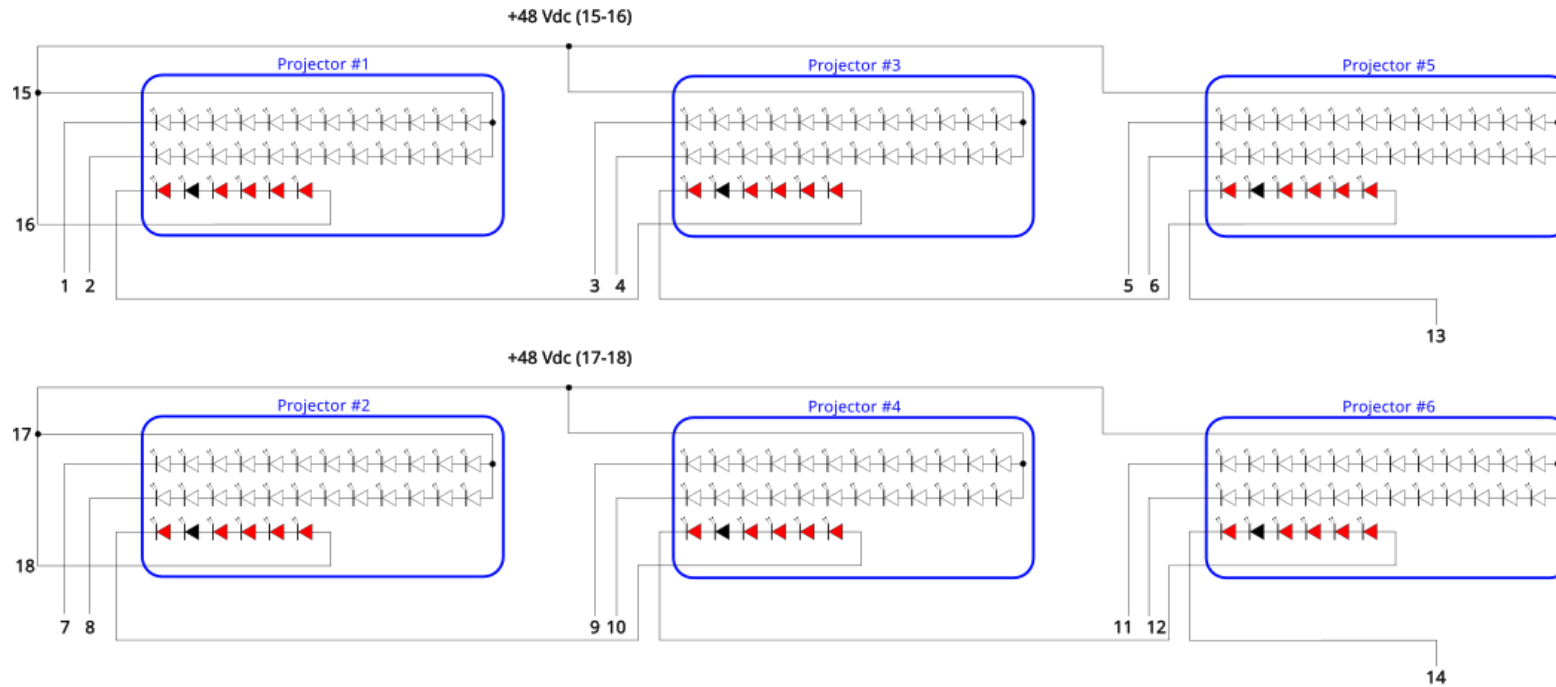

Configuration for R/IR circuit (13-14):

Red led only: 6 red led

Red and Infrared: 5 red led ans 1 Infrared led

Infrared Only: 6 Infrared led

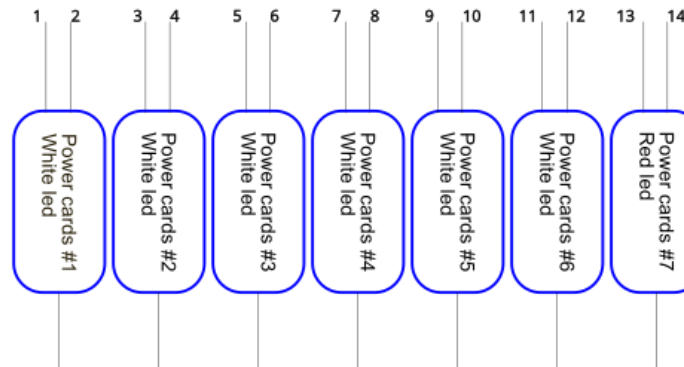

Obsta

3, impasse de la blanchisserie  
51052 Reims CEDEX - FRANCE

This document is the property of OBSTA. It may not be reproduced or communicated to third parties without the written permission of OBSTA.

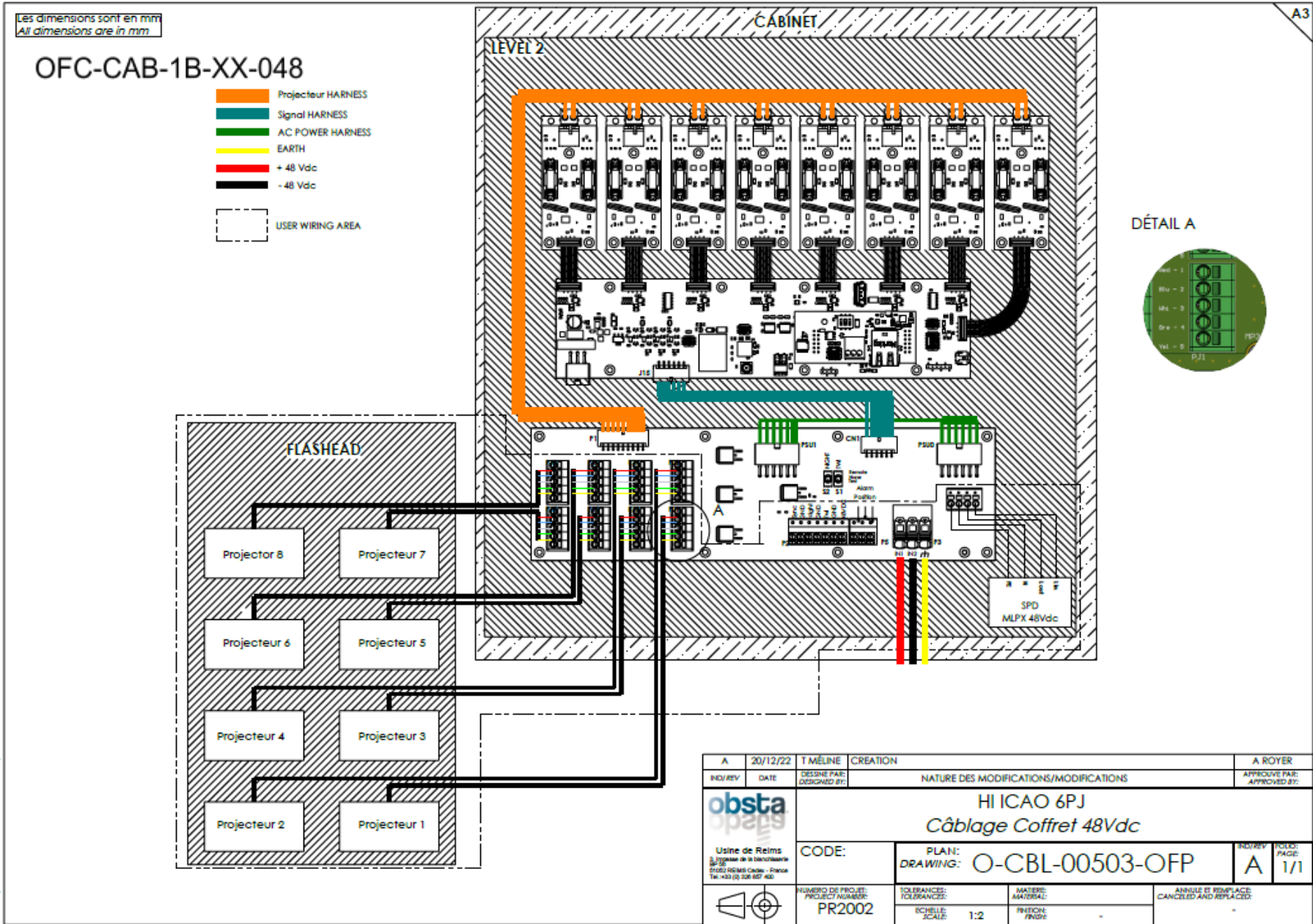

This drawing & covers are the property of OBSTA. This document cannot be reproduced, copied or communicated with third parties without the authorization of OBSTA.  
 Ce document est la propriété d'OBSTA. Il ne peut être reproduit ou communiqué à des tiers sans l'autorisation écrite d'OBSTA.  
 Seul le plan PDF est contractuel. Only the PDF Draw is contractual.

Les dimensions sont en mm  
All dimensions are in mm

A3

OFC-CAB-1B-XX-240

- Projecteur HARNESS
  - Signal HARNESS
  - AC POWER HARNESS
  - DC POWER HARNESS
  - EARTH
  - LINE
  - NEUTRAL
- USER WIRING AREA

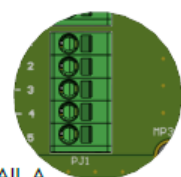
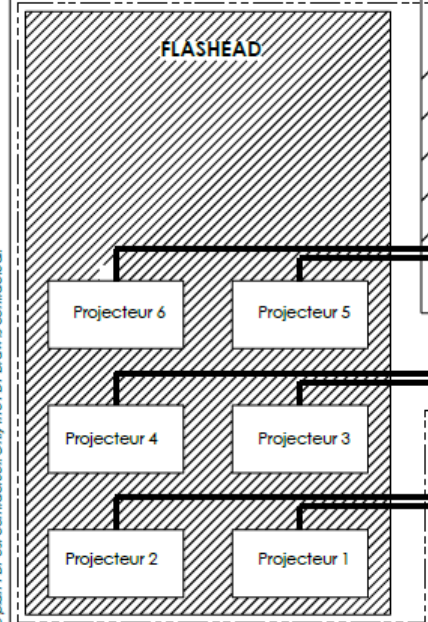
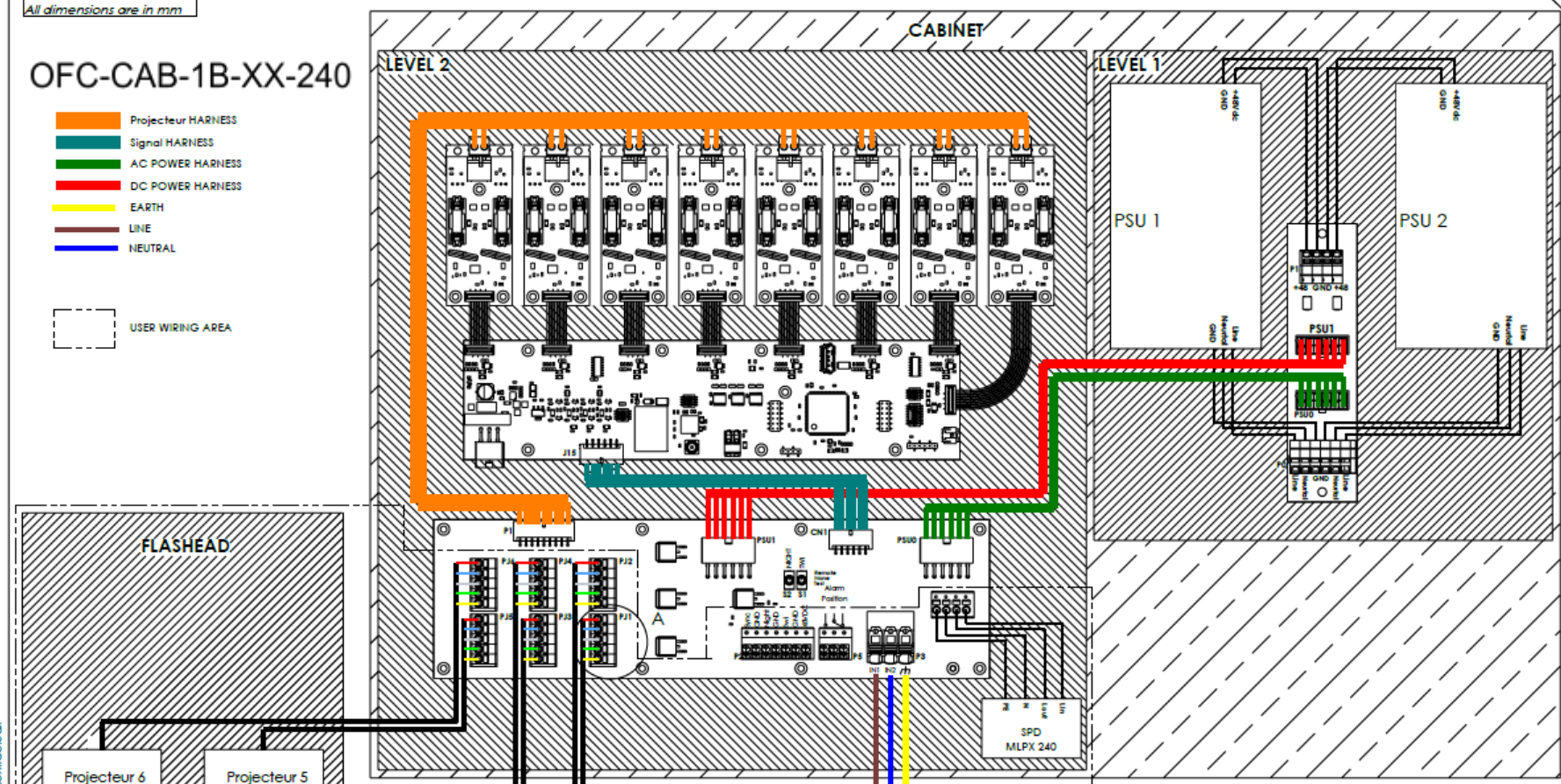

DÉTAIL A

This drawing is the property of OBSTA. This document cannot be reproduced, copied or communicated with third parties without the authorization of OBSTA.  
 Ce document est la propriété d'OBSTA. Il ne peut être reproduit ou communiqué à des tiers sans l'autorisation écrite d'OBSTA.  
 Seul le plan PDF est contractuel. Only the PDF Draw is contractuel.

A	18/01/23	T MÊLINE	CREATION	A ROYER
IND/REV	DATE	DÉSSINE PAR: DESIGNED BY:	NATURE DES MODIFICATIONS/MODIFICATIONS	APPROUVE PAR: APPROVED BY:
obsta opaps		HI ICAO 6PJ Câblage Coffret blanc / rouge		
Usine de Reims 3 Impasse de la Blanchisserie BP 20 51092 REIMS Cedex - France Tel: +33 (0) 328 957 400		CODE:	PLAN: DRAWING: O-CBL-00507-OFF	IND/REV: A FOCUS: PAGE: 1/1
NUMÉRO DE PROJET: PROJECT NUMBER: PR2002		TOLERANCES: TOLERANCES: ECHÈLE: SCALE: 1:2	MATÉRIEL: MATERIAL: FINITION: FINISH:	ANNULÉ ET REMPLACÉ: CANCELED AND REPLACED:

## 8. Operation and configuration

### 8.1 Terminal connexion

(1) Synchronization: in cases where several blocks are connected to lamps that need to be synchronized, connect the two “sync” terminals with a cable

(8. Typical applications). This is referred to as a master/slave configuration. All settings (flash sequence, photocell, etc.) must be managed solely by the master unit. To define the slave units, use the dip switches (5.2 Switch configuration).

(2) Ground

(3) Night: The change of state occurs when the photocell switches to “night” mode.

(4) Twilight: The state change occurs when the photocell switches to “twilight” mode.

(5) Ground

(6) +48V: Photocell supply

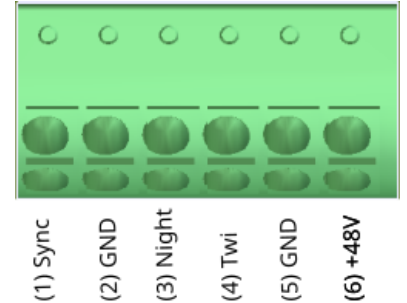

Bloc #1: Alarm relay NO / COM / NC

Bloc #2: Alarm relay NO / COM / NC

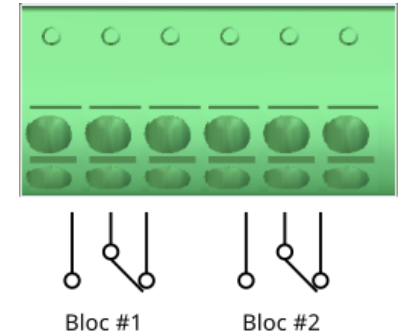

(7) Bus\_H : Only with controller OFH-CTR-CAN

(8) Bus\_L: Only with controller OFH-CTR-CAN

(9) Ground

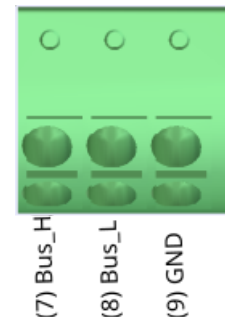

## 8.2 Switches configuration

### 8.2.1 SW1-Configuration

Configuration is set in the factory as the topology of the systems.

**Changing the switches without Obsta approval may cause irreversible damage either to the lamp or the power supply.**

### 8.2.2 SW2-GPS

Configuration of the GPS (**GPS antenna with 5m RG174 SMA male**) for flash synchronization (**the SW3 must be set to master**).

GPS is used to synchronise flashes based on the UTC clock.

N°	1	2*	3*	4
<b>ON</b>	GPS used	Sync 0.0	Sync 1.0	ORD → Override the mode and force it into Day mode
<b>OFF</b>	GPS not used	Sync 0.1	Sync 1.1	ORN → Override the mode and force it into Night mode

*2 (Sync 0)	*3 (Sync 1)	Comment
<b>OFF</b>	<b>OFF</b>	Flash sequence start at the second "0" of each minute (Default setting as per regulation)
<b>OFF</b>	<b>ON</b>	Flash sequence delayed by 1/13 <sup>th</sup> of period from second 0 (Special case for catenary lighting)
<b>ON</b>	<b>OFF</b>	Flash sequence delayed by 3/13 <sup>th</sup> of period from second 0 (Special case for catenary lighting)
<b>ON</b>	<b>ON</b>	Flash sequence start at the second "1" of each minute (Setting as per old installation)

During initialization after start-up, the GPS chip waits for a precise signal. When preliminary signals are received, the GPS status LED may blink or light up (Operation led). Once the preliminary signals have been received, it may take up to 15 minutes for the card to receive a complete, valid signal, enabling the product to synchronize correctly. During this phase, synchronization may not be fully valid and a GPS fault may occur. We recommend to wait at least 20 minutes before considering the synchronization valid. If a GPS default led is still activated after 20 minutes, the product is not receiving signals correctly.

If GPS is used and signals is not found:

- Flash rate is set up at 15 FPM
- If also used for Day/Twilight/Night mode, the mode is forced to night mode.

If the system is in slave mode and using external signals for synchronization coming from a top sync or a controller, in case of defect of signal, the GPS is automatically used for the flash and day/twilight/night mode:

- Flash synchronization is done as per dip-switches 3 and 4 on SW2
- Day/Twilight/Night mode is done as per astronomical twilight (the sun is  $-6^\circ$  below the horizon)

### 8.2.3 SW3 - Control

N°	1	2	3*	4*
<b>ON</b>	Operation	Master	ORN - 0.0	ORD - 1.0
<b>OFF</b>	Reset	Slave	ORN - 0.1	ORD - 1.1

- ORD → Override the mode and force it into Day mode
- ORN → Override the mode and force it into Night mode
- ORT (ORN + ORD) → Override the mode and force it into Twilight mode

*3(ORN)	*4 (ORT)	Comment
<b>OFF</b>	<b>OFF</b>	-
<b>OFF</b>	<b>ON</b>	ORD
<b>ON</b>	<b>OFF</b>	ORN
<b>ON</b>	<b>ON</b>	ORT

### 8.2.4 SW4 - Mode

This switch selects which Day / Twilight/ Night sensor is used on the product:

N°	1	2	3*	4*
<b>ON</b>	Photores (detected if D/T/N)	External	GPS	Alarm used
<b>OFF</b>	-	-	-	Alarm not used

If GPS is selected, the GPS will use the astronomical definition for Twilight / Night mode.

## 8.3 Default

### 8.3.1 Operation led

	Default	Condition	Red led signal	Lamp signal
<b>D0</b>	Power supply voltage	Detected if there is a power supply issue (Over-voltage or under-voltage)	..... short and continuous blinking	OFF
<b>D1</b>	Invalid configuration	Means inconsistency in dip-switches, for any of the following reasons: <ul style="list-style-type: none"> <li>• GPS is disabled and Sync 1 + Sync 0 are set</li> <li>• Several sensor for switching mode are set</li> <li>• The selected configuration number does not exist</li> </ul>	—... 1 long and 3 short	OFF
<b>D2</b>	Power card default error	Default from either Power card or projector causing insufficient light	.. 2 short	-
<b>D3</b>	Light channels relay error	Default from either power card or projector causing insufficient light	. 1 short	-
<b>D4</b>	GPS out of synchronization	GPS is in used and no signal accurate is received	—... 1 long and 2 short	15 FPM
<b>D5</b>	Slave out of synchronization	Card in slave mode and no synchronization signal during 10sec	—. 1 long and 1 short	15 FPM
<b>D6</b>	D/T/N mode unchanged	The mode did not change since the last 48 h	— 1 long	-
<b>D7</b>	External communication problem	Communication though Ethernet or CAN date link has failures	— — 2 long	-
<b>D8</b>	GPS default	If GPS is out of synchronization but has been synchronized since last 15 minutes: working on internal clock	Same as Lamp flash	-

The "lamp signal" column indicates if the activation of a given default modifies the current sequence of currently activated mode (When "OFF" is specified, it means that no flash shall occur).

This sequence shall last until corresponding default is cleared, and if several defaults are present, only the sequence of highest priority default shall be applied.

## 8.3.2 Power card led

Power card error	Error condition	Persisted	Power card default led sequence
<b>Short circuit</b>	Some or all led are not working	NO	• 1 short
<b>Open circuit 1</b>	Both led circuit piloted by the power card are in open circuit	NO	•— 1 short and 1 long
<b>Current regulation issue 1</b>	Power card cannot set the according current on both circuit led	YES	•— 1 short and 2 long
<b>Open circuit 2</b>	One of the two led circuit piloted by the power card is in open circuit	NO	— Same as lamp flash
<b>Current regulation issue 2</b>	Power card cannot set the according current on one circuit led	YES	— Same as lamp flash and follow by 1 short

## 8.3.3 Alarm

Alarm will be set when some conditions are met, depending on the configuration and switches. (Only activate if switch 3.4 is set).

*Alarm errors are described in 6.3.1.*

## 9. Installation

### 9.1 Unpacking

Carefully unpack each item and remove any internal packing material from the power supply and the Lamp. Examine each item for obvious physical damage. Report any claims to the carrier immediately.

### 9.2 Mounting and preparation

Any manual intervention must be performed on a NON-POWERED product. Human and material issues could occur inducing injury or permanent damage to the product.

Depending on the application multiple flash units may be required. Obsta recommends that each unit has its own support (One supports the kit : Flash-head + Cabinet). Cabinet or Flash-head must be installed in a fixed position. Obsta also recommends that the cabinet shall be in an easy access position/orientation for maintenance purposes. Each part of the kit must be correctly fixed to the structures.

***The flash must be levelled using a spirit level.***

1. Verify that the mounting surface is free of debris.
2. Align the five mounting holes in the base of the flash-head with the holes in the structure mounting plate.
3. Secure losing the flash-head on its support. Do not tight up screws yet.
4. Ensure that the flash-head is installed horizontally by using the level provided (air bubble shall be centered).
5. If the flash-head is not leveled, add stainless steel shim material or washers (stainless steel or galvanized) as necessary to level the flash-head.
6. Once leveled, firmly secure the hardware once the flash-head, using the same torque on each screw. Verify that the flash-head is level when the hardware is fully tightened. If not leveled, then loosen the mounting hardware and repeat Step 5 until the beacon is firmly secured horizontally.

***Cabinet shall be placed in upright position (cable glands face to the ground)***

***Cable shall be installed with cable clamp to avoid any oscillation moveênt due to wind pressure.***

In some specific cases with high electromagnetic fields an additional shield is required to ensure proper operating. OBSTA may provide or suggest additional equipment to improve stability and durability of the kit. Please contact OBSTA if the product may be exposed to this kind of perturbation.

Otherwise the cross section of the power cable as per the maximum current of 14A during the day time

The two (120°) or three (180°) spotlights are mounted on the bracket at 120° or 180°. They are tightened to a torque of 5N.m with M8 nuts and washers as follows:

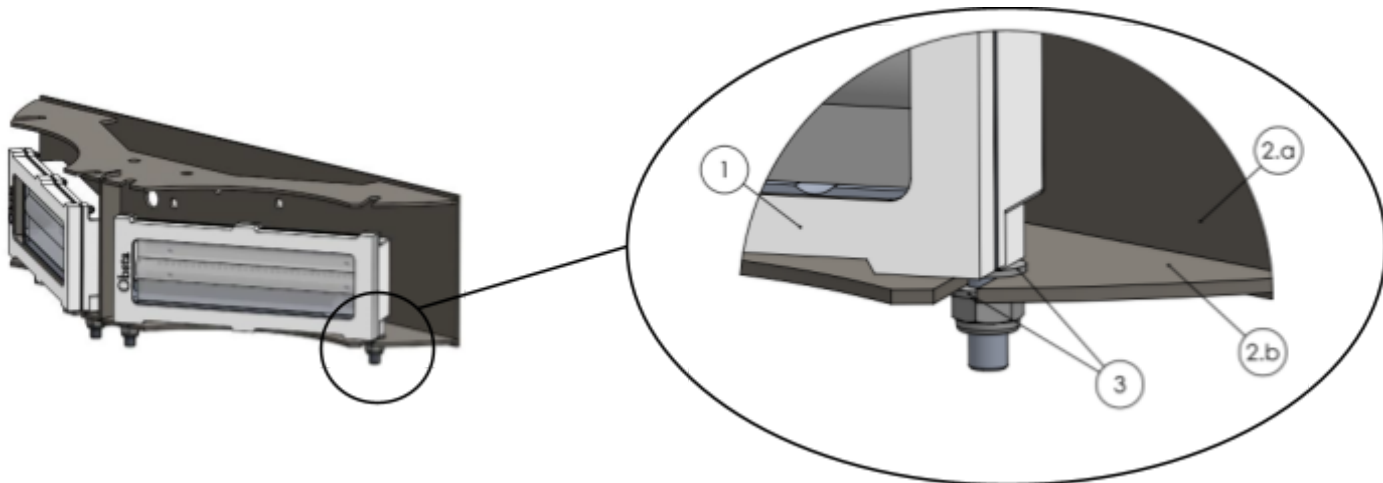



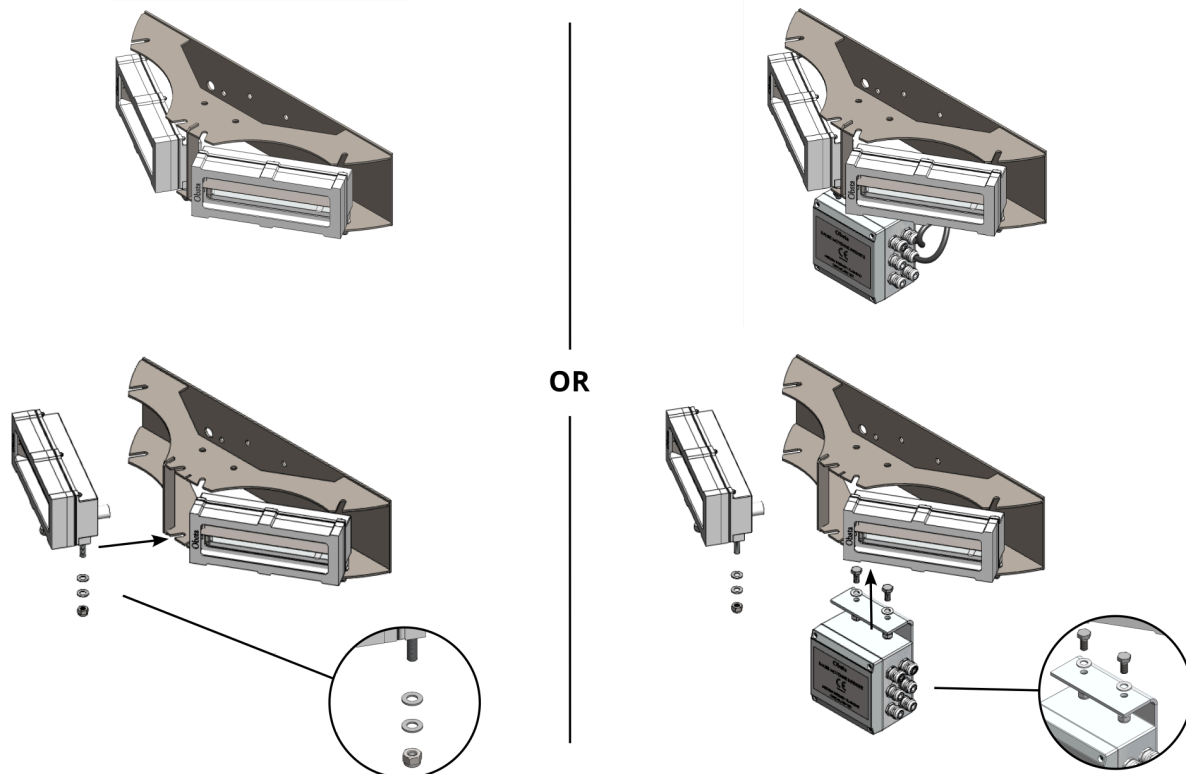

N°	Designation
1	MI LED projector
2	120°Bracket (available in 180°)
3	M8 nut(x1) and washer (x2)



OR

Obsta  
3, impasse de la blanchisserie  
51052 Reims CEDEX - FRANCE

## 9.3 Wiring overview

-  - 1 → White channel power supply
-  - 2 → Return to Blanc lane
-  - 3 → Return to white lane
-  - 4 → Return to the Red Lane
-  - 5 → Return to the Red Lane

	For dual color or white only Obstaflash systems			
<b>Cable length</b>	1-60 m (1-200 ft)	61-105 m (201-350 ft)	106-160 m (300-510 ft)	161-215 m (511-700 ft)
<b>Cable diameter</b>	2.5 mm <sup>2</sup> (12 awg)	6 mm <sup>2</sup> (10 awg)	7.5mm <sup>2</sup> (8 awg)	10mm <sup>2</sup> (7 awg)

### The KIT 113758UA includes:

#### TOP:

- 3 flash\_heads with 10 meters of molded cable (P/N 113747-U-10)
- 1 DC power unit (P/N 114103)

#### BOTTOM:

- AC power cabinet (P/N 113797U) + photocell 100757 and cable 5 core

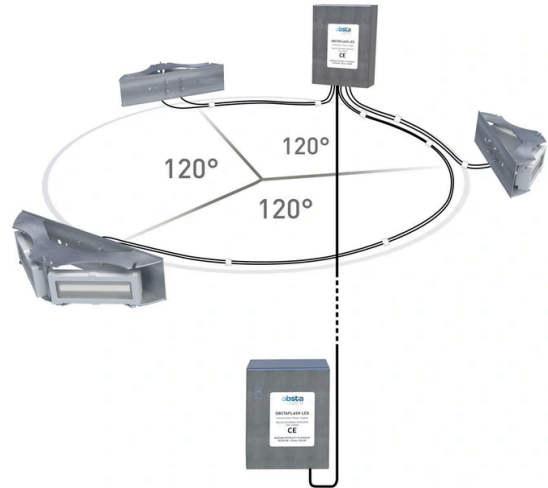

***For all kits, it is possible to add a photoelectric cell for the day/night switch connected to the power supply unit. (Reference 100757)***

## 10. Maintenance

### 10.1 Annual visit

Test	Frequency	Preventive action	Risk
<b>Cable</b>	Annual	<ul style="list-style-type: none"> <li>Tighten power card connector screw</li> <li>Tighten projector connector plugged on the PSU</li> </ul>	Short or open circuit
<b>Waterproof</b>	Annual	Search the water leak	No water inside
<b>Corrosion</b>	Annual	Replace defective part	No excessive corrosion
<b>Power supply</b>	Annual	Replace the defect part if necessary	Led status indicator
<b>Led projector</b>	Annual	Clear, with humid cloth the glass of watch projector	Poor light intensity
<b>Led projector</b>	Annual	Check that all projectors are tight	Lamp not correctly aligned

### 10.2 Spare part

PROJECTOR (Specific for FAA version)	<b>113761UIR</b>
COMMAND-CARD-48VDC-6P-RW	<b>113744B</b>
POWER SUPPLY BLOC + SUPPLY CARD	<b>113742B</b>
POWER CARD 48VDC	<b>113741B</b>

#### **External power cabinet - 113797U**

Security switch and test button	<b>113743</b>
Surge protection DS215-230/G 240VAC	<b>451721</b>
Power Supply (AC/DC Converter)	<b>113742</b>

#### **Accessories**

Photocell	<b>100757</b>
NAVILITE L-810(F)	<b>113969IR-F</b>

## 11. Technical specifications

### 11.1 Light output

Name	Parameter	Min	Nominal	Max	Unit
$FL_{rate}$	Flash Rate	-	40 (white mode) 30 (red mode)	-	FPM
$B_{pat}$	Beam pattern				
$BP_h$	Horizontally	-	360	-	°
$BP_v$	Vertically	3	5	6	°
$BP_{ri}$	Ratio Intensity 0°/ 10°	-	-	3	%
$LUM_{day}$	Day luminosity +- 25%	-	20 000	-	Cd
$LUM_{twi}$	Twilight luminosity +-25%	-	20 000	-	Cd
$LUM_{night}$	Night luminosity +-25%	-	2 000	-	Cd
$FD_{day}$	Flash duration day	-	100	-	ms
$FD_{twi}$	Flash duration twilight	-	100	-	ms
$FD_{night}$	Flash duration night	-	200	-	ms

### 11.2 Electrical input for 48Vdc

Name	Parameter	Min	Nominal	Max	Unit
$V$	DC power input voltage	45	50	55	Vdc
$I_{max}$	Max current (white day mode)	-	-	13.8	A
$P_{avc}$	Average power consumption ( <i>with 40fpm - 100ms day mode</i> )	-	-	50	W
$V_{logic}$	Voltage for signal (synchro, night, twilight)	30	48	55	Vdc

## 11.3 Electrical input for 120/ 240 Vac

Name	Parameter	Min	Nominal	Max	Unit
<b>V</b>	AC power input voltage	110	120 /240	264	Vac
<b>F</b>	AC frequency	47	50/60	63	Hz
<b>V</b>	DC output voltage for the flash head	-	50	-	Vdc
<b>I<sub>rush</sub></b>	Cold start inrush current	-	-	70	A
<b>P<sub>avc</sub></b>	Average power consumption <i>(with 40fpm - 100ms day mode)</i>	-	-	50	W
<b>V<sub>logic</sub></b>	Voltage for signal (synchro, night, twilight)	30	48	55	Vdc

## 11.4 Operating environments

Name	Parameter	Min	Nominal	Max	Unit
<b>F<sub>wind</sub></b>	Max wind force under 324 km/h (Flash-head)	-	850	-	N
<b>W<sub>T</sub></b>	Working temperature	-40	20	55	°C
<b>HR</b>	Relative humidity	5	-	95	%

## 12. Drawing

OFP 120 (with or without junction box and ICAO or FAA version)

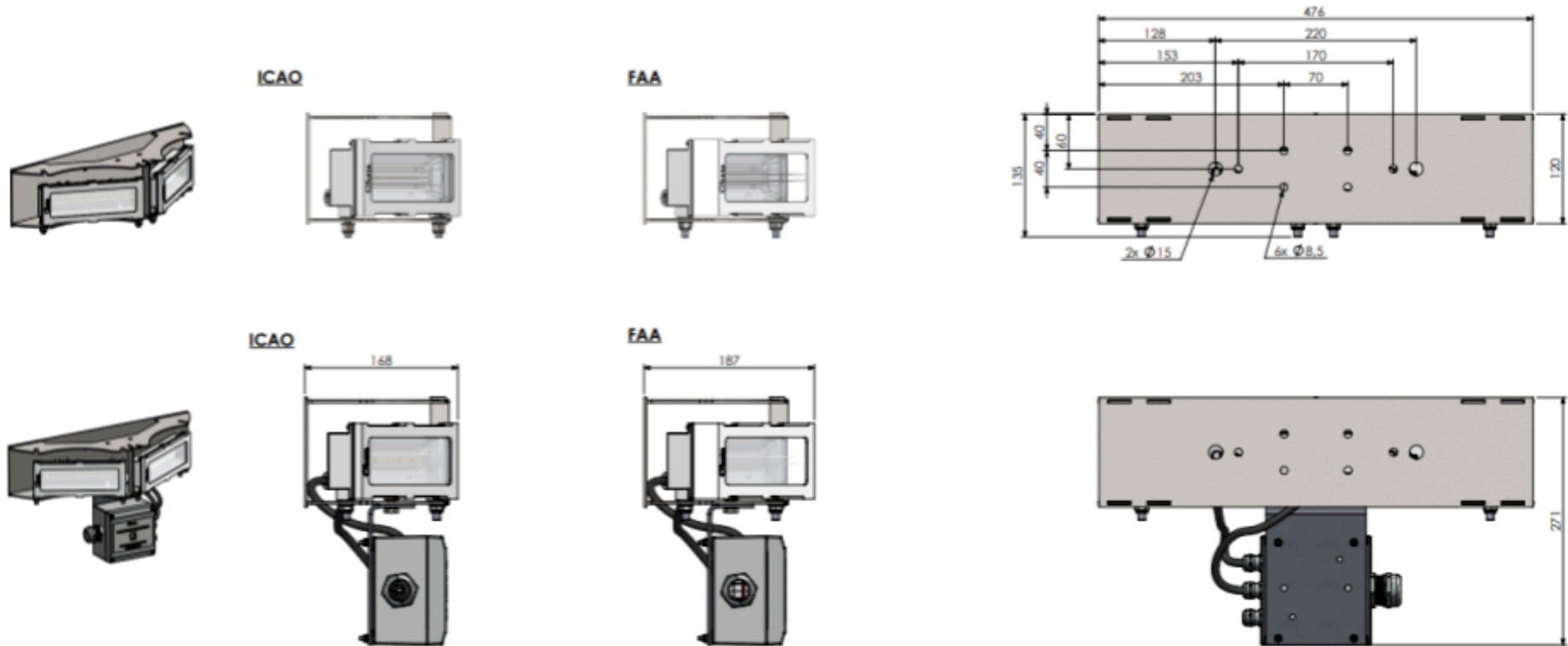

Obsta  
 3, impasse de la blanchisserie  
 51052 Reims CEDEX - FRANCE

This document is the property of OBSTA. It may not be reproduced or communicated to third parties without the written permission of OBSTA.

## 13. Typical wiring

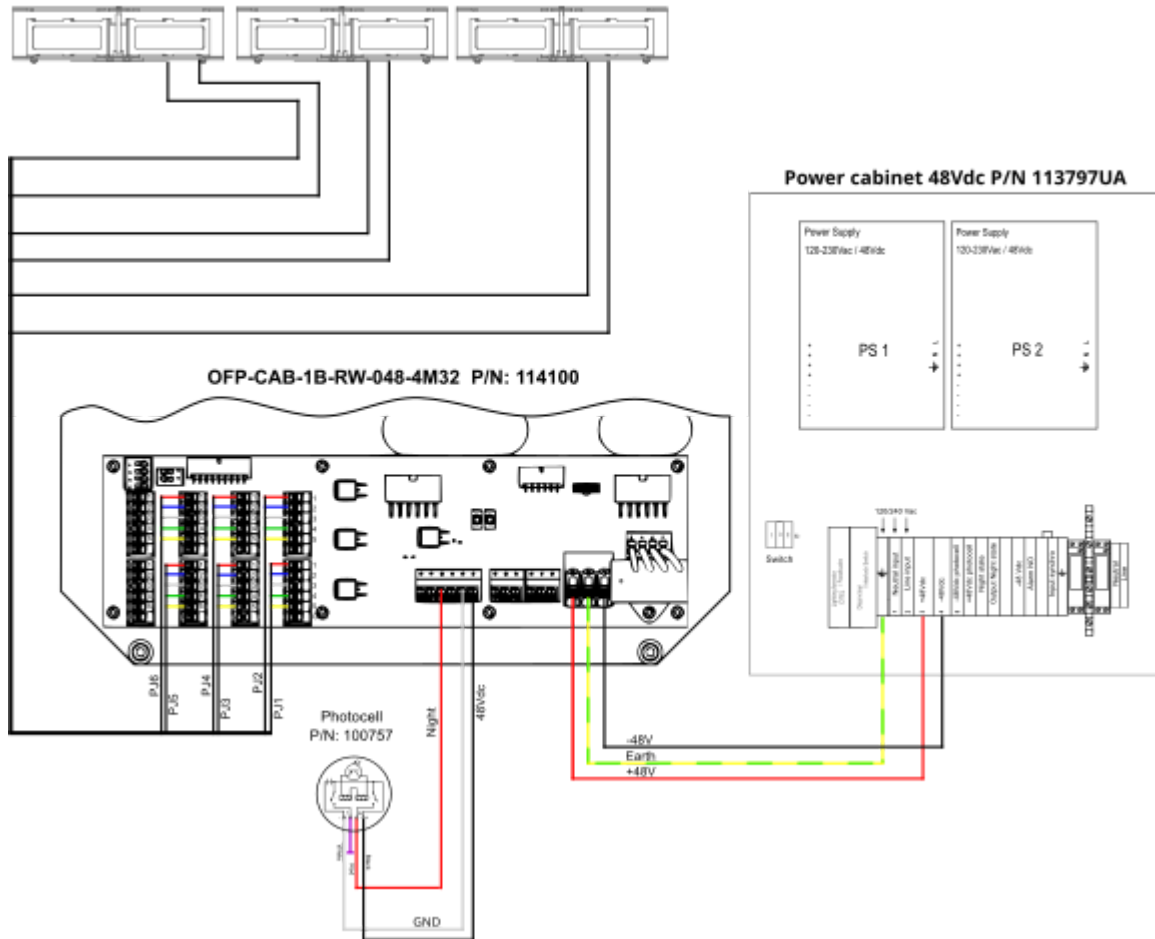

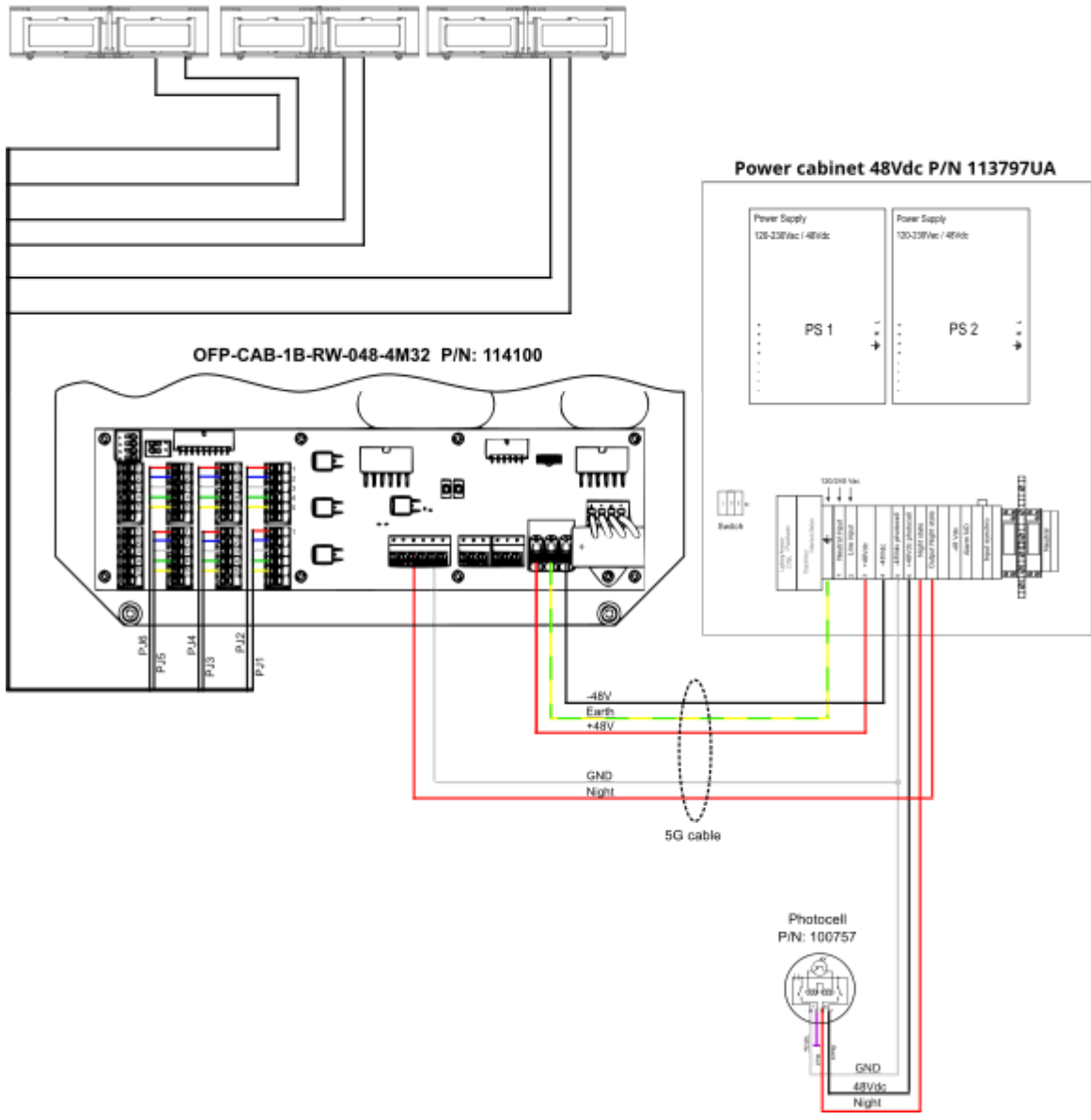

Obsta  
3, impasse de la blanchisserie  
51052 Reims CEDEX - FRANCE

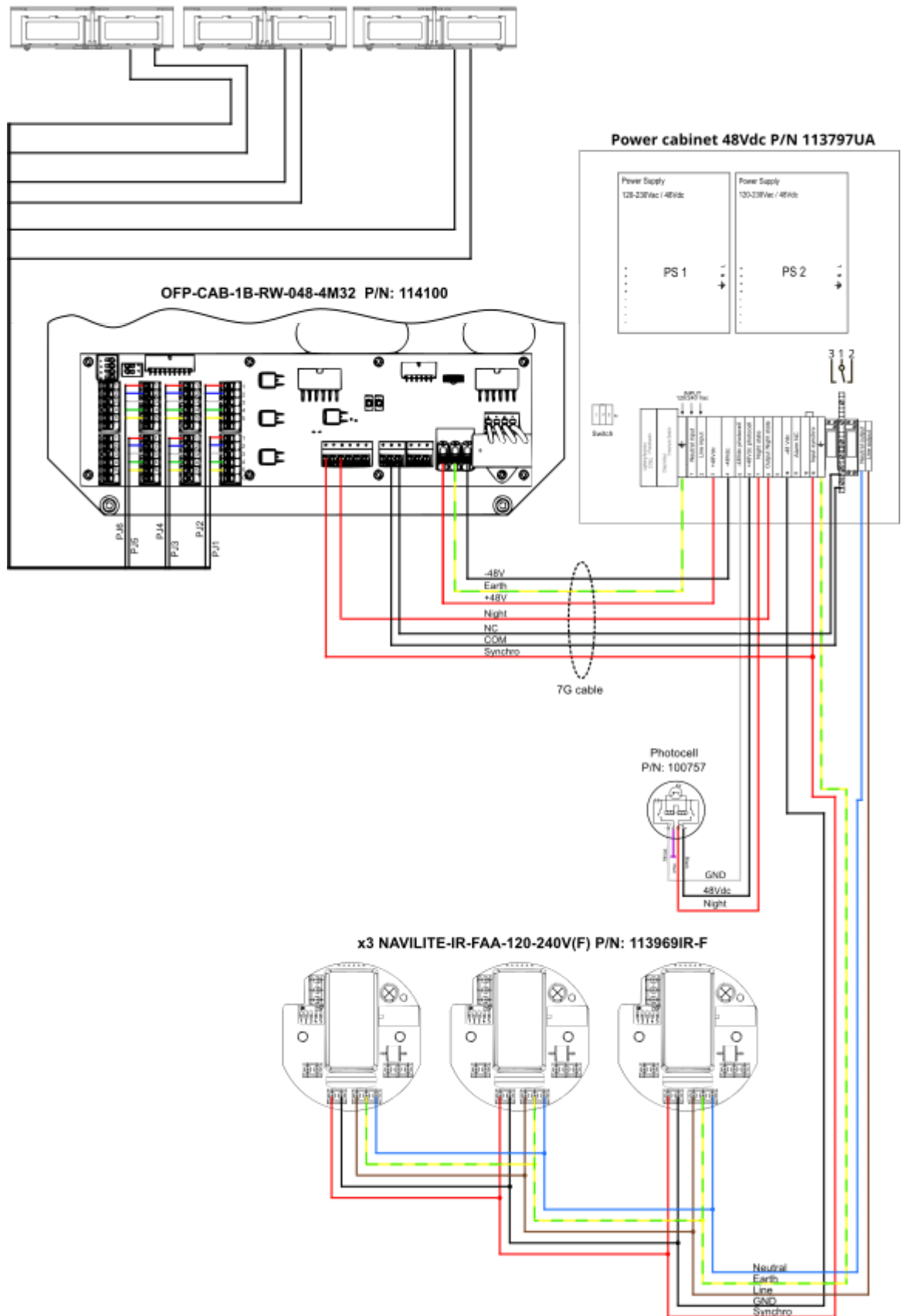

Obsta

3, impasse de la blanchisserie  
51052 Reims CEDEX - FRANCE

This document is the property of OBSTA. It may not be reproduced or communicated to third parties without the written permission of OBSTA.