

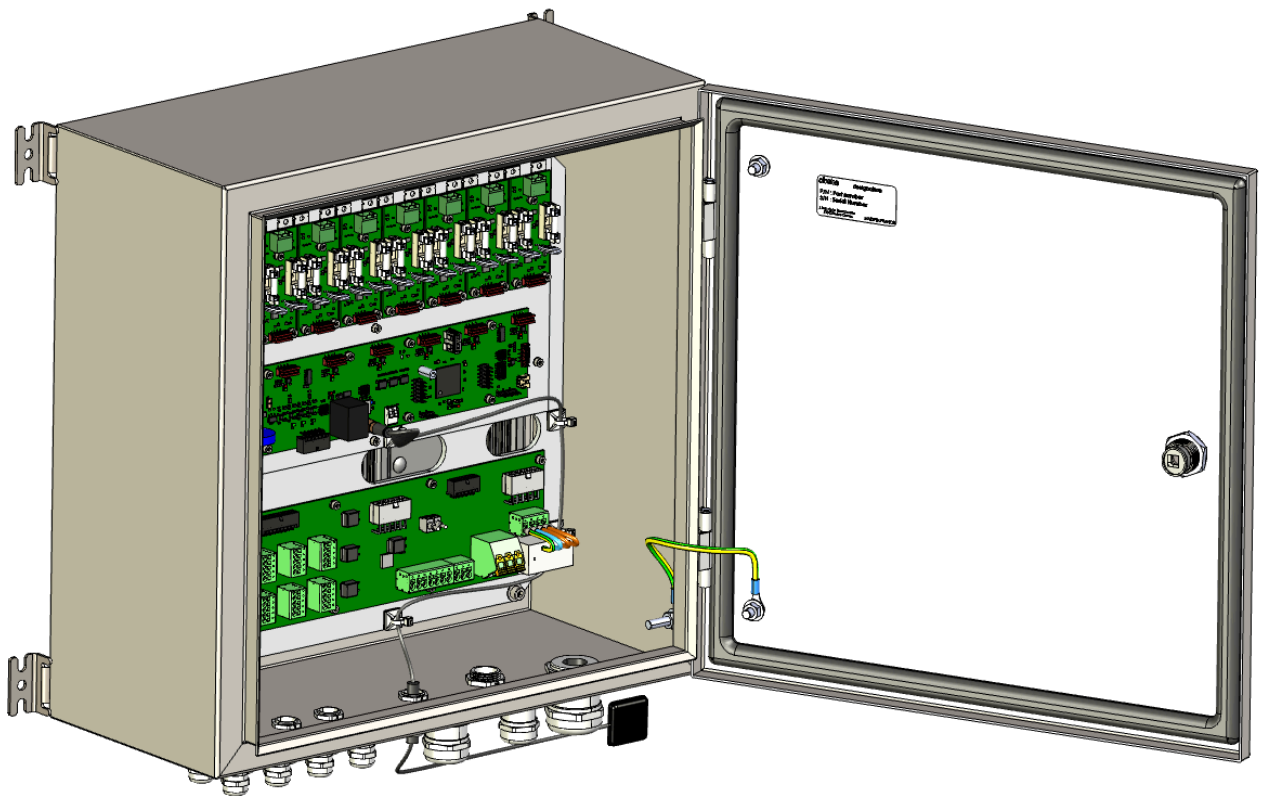

OFP-CAB-1B-RW-048-XXX // OFP-CAB-1B-RW-240-XXX
OFP-CAB-2B-RW-048-XXX // OFP-CAB-2B-RW-240-XXX
OFP-CAB-3B-RW-048-XXX // OFP-CAB-3B-RW-240-XXX
OFP-CAB-4B-RW-240-XXX







Obsta
3, impasse de la blanchisserie
51052 Reims CEDEX - FRANCE

1. Product name and part number.....	3
2. Be careful.....	6
3. Warranty.....	7
4. General information.....	8
4.1 Scope.....	8
4.2 Absolute maximum rating.....	8
4.3 General description.....	9
4.4 Cards inside the power supply cabinet.....	13
4.1.1 1B interconnection card (O-PCB-00037-OFP).....	13
4.1.2 2B,3B,4B interconnection card (O-PCB-00042-OFP).....	14
4.1.3 2B, 3B and 4B generic card (O-PCB-00041-OFP).....	15
4.1.4 Command card (O-PCB-00012).....	16
4.1.5 Power card (O-PCB-00015-OFP).....	21
4.1.6 Alimentation card (O-PCB-00038-OFP).....	21
4.5 Internal Wiring.....	22
5. Operation.....	28
5.1 Switches configuration.....	28
5.1.1 SW1-Configuration.....	28
5.1.2 SW2-GPS.....	28
5.1.3 SW3 - Control.....	29
5.1.4 SW4 - Mode.....	29
5.2 Default.....	30
5.2.1 Operation led.....	30
5.2.2 Power card led.....	31
5.2.3 Alarm.....	31
6. Installation.....	32
6.1 Unpacking.....	32
6.2 Mounting and preparation.....	32
6.2 Cable gland installation.....	33
7. Maintenance.....	34
7.1 Annual visit.....	34
7.2 Spare part.....	34
8. Typical wiring.....	35

1. Product name and part number

Description	Norm	Power supply	Article code (P/N)	QR code
1B (One block)				
OFP-CAB-1B-RW-048-4M32	IP66	48 Vdc ±5%	114100	
OFP-CAB-1B-RW-048-4M32-S	IP66	48 Vdc ±5%	114101	
OFP-CAB-1B-RW-048-8M16	IP66	48 Vdc ±5%	114102	
OFP-CAB-1B-RW-048-8M16-S	IP66	48 Vdc ±5%	114103	
OFP-CAB-1B-RW-240-4M32	IP66	110-240 Vac ±10%	114110	

OFP-CAB-1B-RW-240-4M32-S	IP66	110-240 Vac ±10%	114111	
OFP-CAB-1B-RW-240-8M16-S	IP66	110-240 Vac ±10%	114112	
OFP-CAB-1B-RW-240-8M16-S	IP66	110-240 Vac ±10%	114113	
2B (Two block)				
OFP-CAB-2B-RW-048-4M40	IP66	48 Vdc ±5%	114200	
OFP-CAB-2B-RW-048-6M25	IP66	48 Vdc ±5%	114201	

OFP-CAB-2B-RW-240-4M40	IP66	110-240 Vac ±10%	114210	
OFP-CAB-2B-RW-240-6M25	IP66	110-240 Vac ±10%	114211	
3B (Three Block)				
OFP-CAB-3B-RW-048-4M40	IP66	48 Vdc ±5%	114301	
OFP-CAB-3B-RW-240-3M40	IP66	110-240 Vac ±10%	114300	
4B (Four block)				
OFP-CAB-4B-RW-240-4M40	IP66	110-240 Vac ±10%	114400	

2. Be careful



- Do not proceed any maintenance job when the light is under operation
- Power supply must be shut down when opening the flash-head
- Installation must be performed only by an electrically skilled operator and National electrical installation rules must be respected
- Do not look directly at the projector while it is in operation : Led projectors produce brilliant flashes of lights which can result in temporary or permanent eye damage
- OBSTA products are affected by ESD damage.



3. Warranty

OBSTA warrants the equipment described in the instruction manual and sold to purchasers to be free from defects in material and workmanship at the time of shipment. OBSTA's liability under this warranty being limited to repairing or replacing, at OBSTA's option, items which are returned to it prepaid within twenty four (24) months from shipment to the original Purchaser, or twelve months from commissioning, and found, to OBSTA's satisfaction, to have been defective. In no event shall OBSTA be liable for consequential damages. NO PRODUCT IS WARRANTED AS BEING FIT FOR A PARTICULAR PURPOSE AND THERE IS NO WARRANTY OF MERCHANTABILITY.

This warranty applies only if: (I) the items are used solely under the operating conditions and in the manner recommended in OBSTA's instruction manual, specifications, or other literature; (II) the items have not been misused or abused in any manner or repairs attempted thereon; (III) written notice of the failure within the warranty period is forwarded to OBSTA and the directions received for properly identifying items returned under warranty are followed; and (IV) such return notice authorizes OBSTA to examine and disassemble returned products to the extent OBSTA deems necessary to ascertain the cause of failure. The warranties stated herein are exclusive.

THERE ARE NO OTHER WARRANTIES, EITHER EXPRESSED OR IMPLIED, BEYOND THOSE SET FORTH HEREIN, and OBSTA does not assume, nor does OBSTA authorize anyone else to assume for it, any other obligation or liability in connection with the sale or use of said products. OBSTA's liability on any claim of any kind, including negligence, for loss or damages arising out of or connected with the manufacture, sale, delivery, repair or use of any equipment or services provided by OBSTA shall in no case exceed the price allocable to the item or service or part thereof which gives rise to the claim.

The integrity and reliability of OBSTA aviation obstruction lighting systems is dependent on the use of OBSTA parts and components. To ensure the optimum performance and reliability of your OBSTA system, it is strongly advised that only components and modules manufactured by OBSTA be used.

4. General information

4.1 Scope

This manual provides information about the installation, operation and maintenance of the OFP Power Cabinet manufacturer by OBSTA.

4.2 Absolute maximum rating

Name	Parameter	Min	Nominal	Max	Unit
Electrical properties					
V_{in}	AC power input voltage	100	110 / 240	264	Vac
F	AC frequency	50	-	60	Hz
Mechanical properties					
M_1	Mass 1B	-	20	-	kg
M_2	Mass 2B	-	60	-	kg
M_3	Mass 3B	-	70	-	kg
M_4	Mass 4B	-	80	-	kg
Wind resistance (Face / Lateral)					
F_{wind1}	Max wind force under 324km/h (1B)	-	711 / 366	-	N
F_{wind2}	Max wind force under 324km/h (2B)	-	2670 / 1435	-	N
F_{wind3}	Max wind force under 324km/h (3B/4B)	-	3560 / 1335	-	N
DIM_{cab1}	Cabinet dimension (1B)	-	400x400x300	-	mm
DIM_{cab2}	Cabinet dimension (2B)	-	600x1000x300	-	mm
DIM_{cab34}	Cabinet dimension (3B/4B)	-	800x1000x300	-	mm

4.3 General description

The OBSTA power supply cabinet is a stainless steel or painted steel cabinet whose main function is to power and control OBSTA OFP120 and/or OFP180 lamps.

The range is divided into four product families: 1 block, 2 blocks, 3 blocks and 4 blocks. 1 block consists of a control board, a power board, an interconnection board and a power supply card (for 240Vac models).

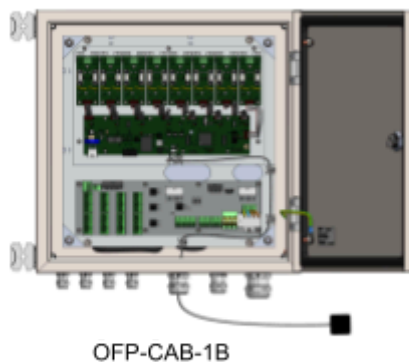

OFP-CAB-1B



OFP-CAB-3B



OFP-CAB-2B



OFP-CAB-4B

The OBSTAFASH power supply cabinet is also used to control the flashlight. With one controller (one block), you can connect 6 projector.

Bill of material of 1B cabinet:

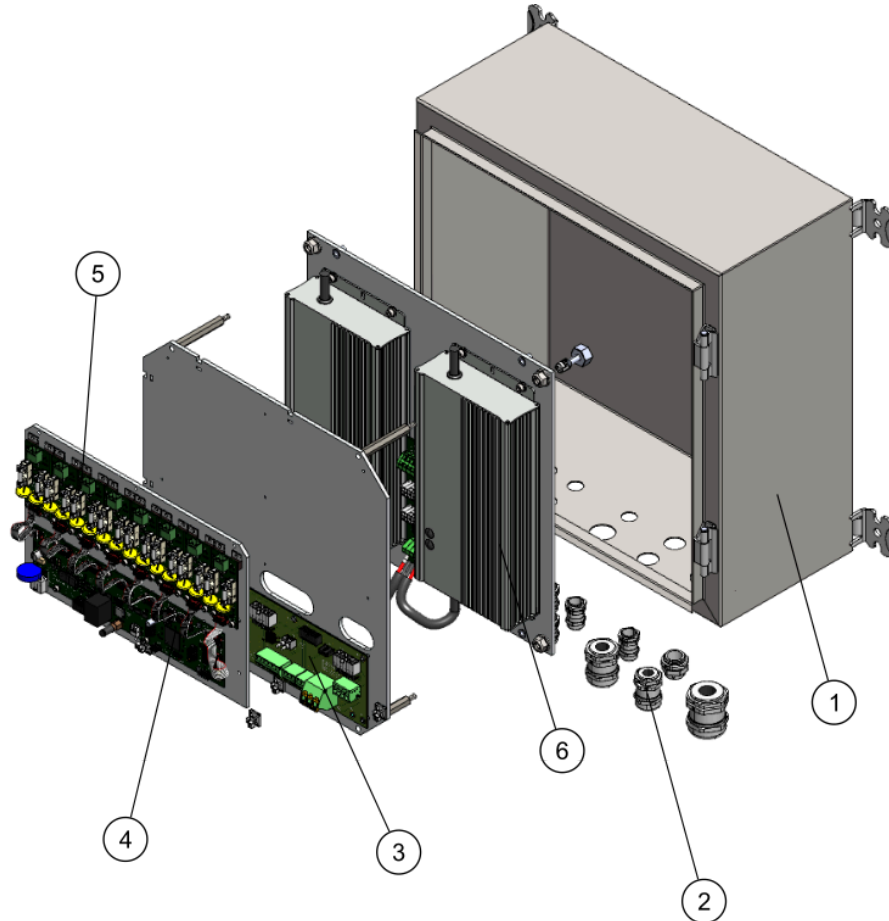

1	Cabinet
2	Cable gland* (M16, M20, M25, M32, M40) *see 6.2 for detail
3	Interconnection card
4	Command card
5	Power card
6	Power supply and alimentation card (only for 240 Vac version)

Bill of material of a generic block (mounted on 2B, 3B and 4B):

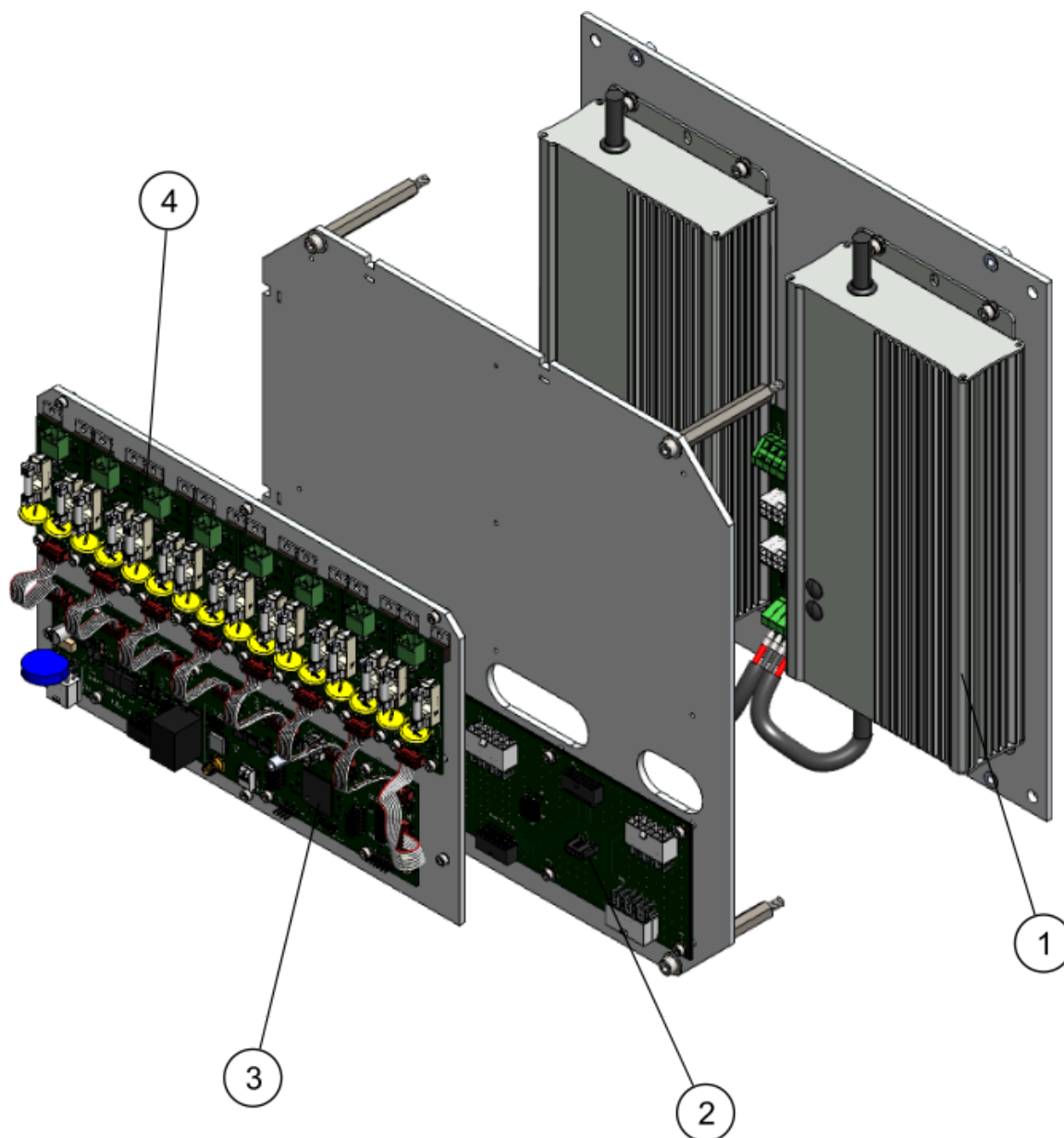

1	Power supply and alimentation card (only for 240 Vac version)
2	Interconnection card
3	Command card
4	Power card

4.4 Cards inside the power supply cabinet

4.1.1 1B interconnection card (*O-PCB-00037-OFP*)

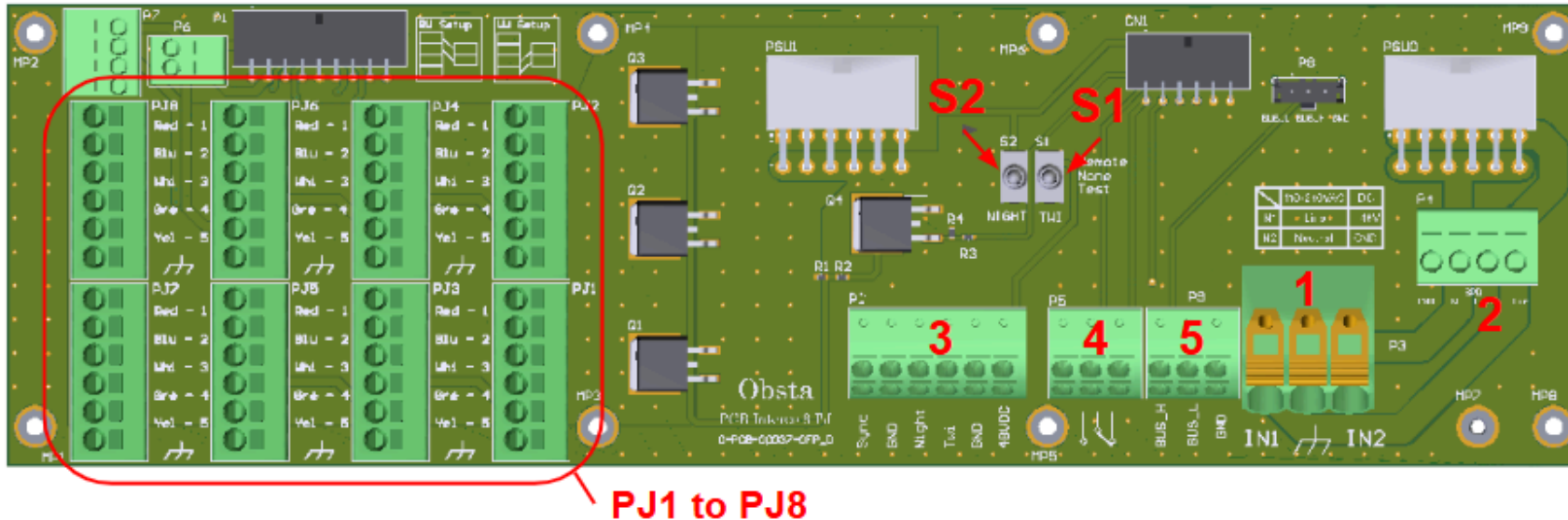

- PJ1 to PJ8/ Projector connector must be connected according to the cable color or number. Other harnesses are cabled directly from the factory. Do not modify the cabling without Obsta's direct consent.
- 1/ Power input: +/-/Earth (Vdc) or L/N/Earth (Vac)
- 2/ Surge protection terminal
- 3/ Communication signal for flash and mode (day, night) from photocell signal and top synchro
- 4/ Alarm : NO/ COM/ NC
- 5/ Communication BUS terminal
- S1/ Test switch for twilight. manual force the signal to twilight (Must be always in remote position for normal operation)
- S2/ Test switch for day/night. manual force the signal to day/night (Must be always in remote position for normal operation)

Obsta
3, impasse de la blanchisserie
51052 Reims CEDEX - FRANCE

This document is the property of OBSTA. It may not be reproduced or communicated to third parties without the written permission of OBSTA.

4.1.2 2B,3B,4B interconnection card (*O-PCB-00042-0FP*)

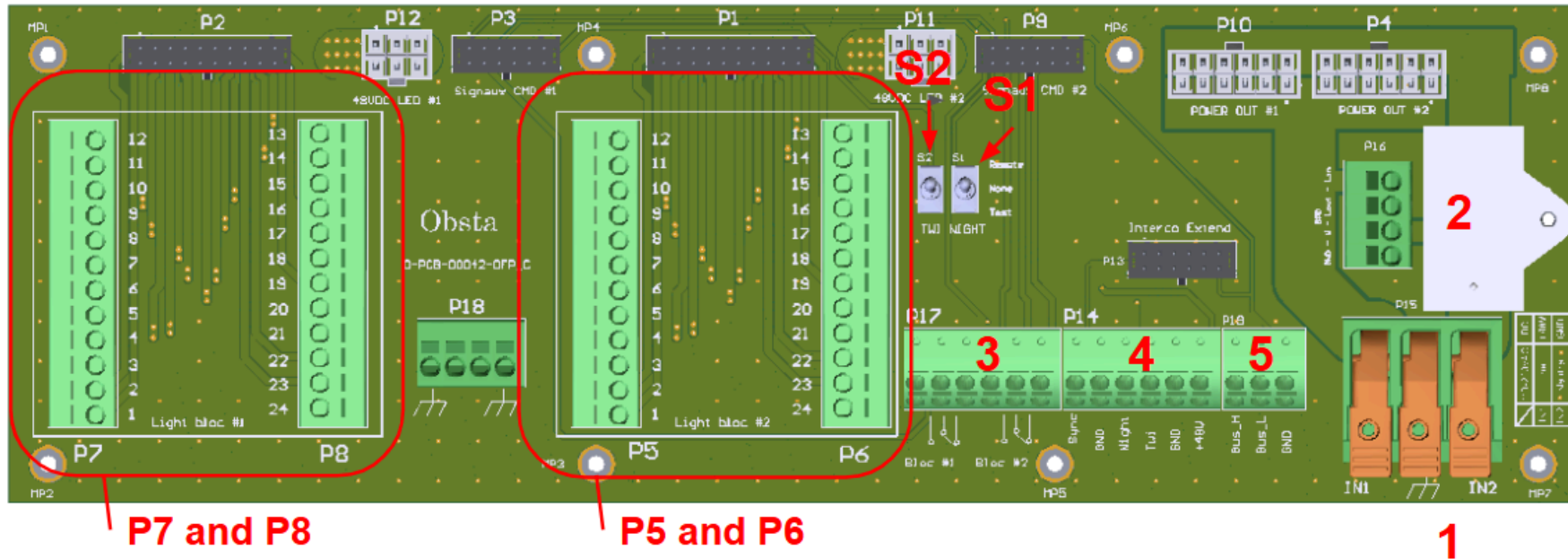

- P5, P6, P7 and P8/ Projector connector must be connected according to the cable color or number. Other harnesses are cabled directly from the factory. Do not modify the cabling without Obsta's direct consent.
- 1/ Power input: +/-/Earth (Vdc) or L/N/Earth (Vac)
- 2/ Surge protection terminal
- 3/ Communication signal for flash and mode (day, night) from photocell signal and top synchro
- 4/ Alarm : NO / COM/ NC
- 5/ CAN terminal
- S1/ Test switch for twilight. manual force the signal to twilight (Must be always in remote position for normal operation)
- S2/ Test switch for day/night. manual force the signal to day/night (Must be always in remote position for normal operation)

Obsta
3, impasse de la blanchisserie
51052 Reims CEDEX - FRANCE

This document is the property of OBSTA. It may not be reproduced or communicated to third parties without the written permission of OBSTA.

Inside 3B & 4B there are 2 interconnection cards, connected together through a harness. All communication signals are connected together. For this reason, user needs only to fully cable one of the PCBa for signal. Both cards need to be cable separately for power.

4.1.3 2B, 3B and 4B generic card (**O-PCB-00041-OFP**)

This generic card is only to relay harnesses and signal to each block from the main interconnection card.

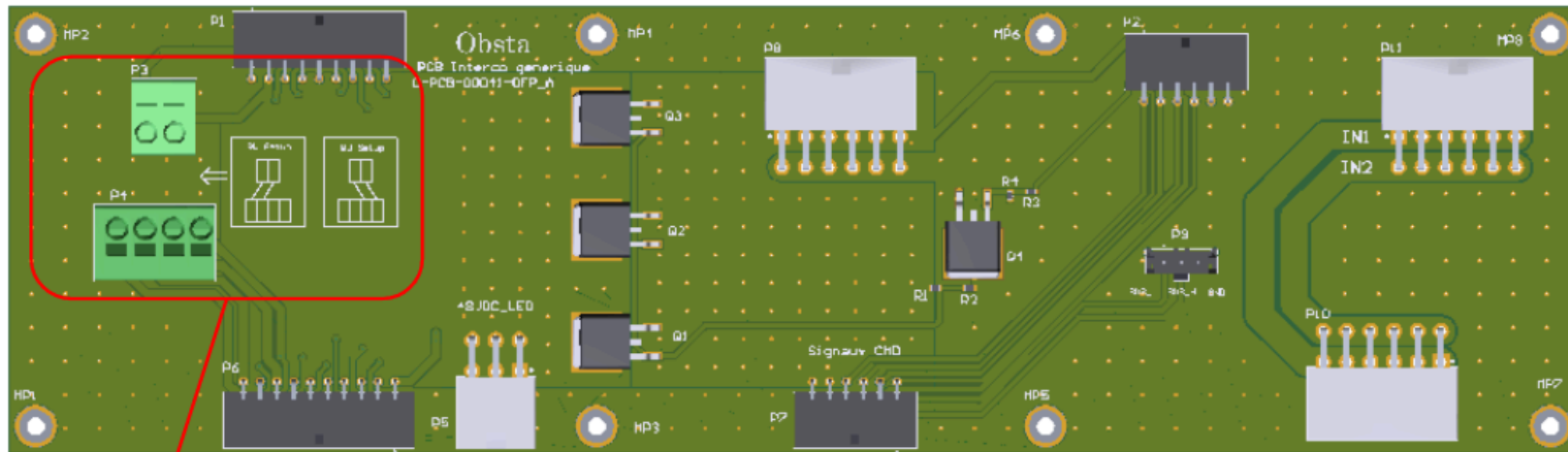

Red/White setup or White/White setup

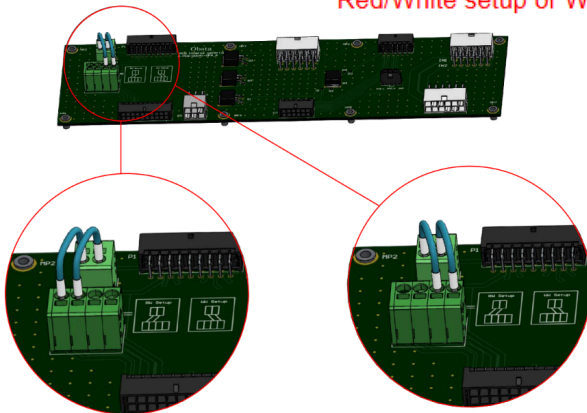

Obsta
3, impasse de la blanchisserie
51052 Reims CEDEX - FRANCE

This document is the property of OBSTA. It may not be reproduced or communicated to third parties without the written permission of OBSTA.

4.1.4 Command card (*O-PCB-00012*)

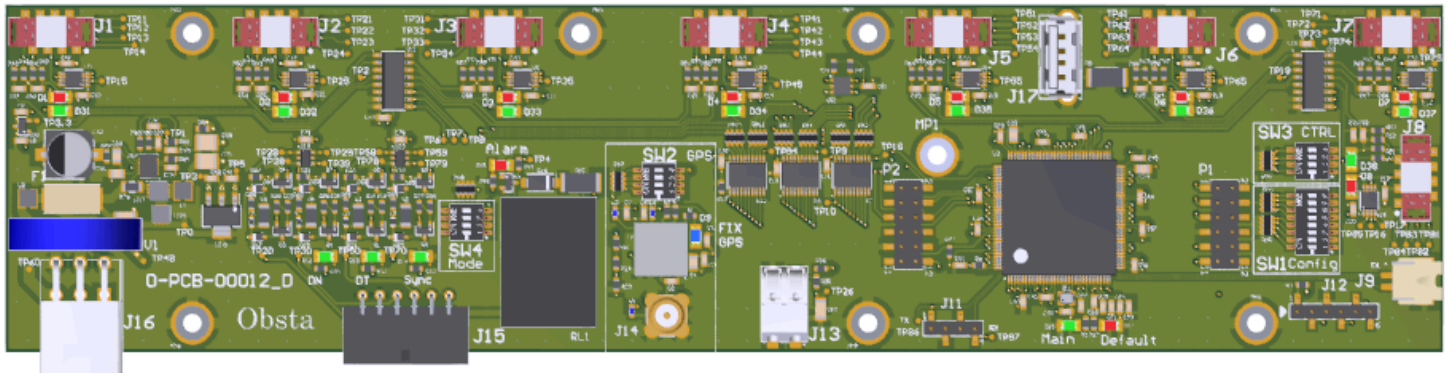

This part is responsible for managing the whole flash head. The embedded microcontroller can analyse input signals (such as GPS, various external signals) and act accordingly.

**Detail on next page*

- J1 to J7: Connected to a dedicated power card. Near each connector, a pair of led (Green & Red) is signaling the status of the power card hence the associated projector, see figure 4 below.
- J9: Connected to another command board for internal synchronization (specific).
- J13: Connector for photo resistor application (specific).
- J14: Connector for GPS antenna.
- J16: USB connector used for reprogramming the Card and retrieving event log (don't operate any USB device without Obsta's consent).

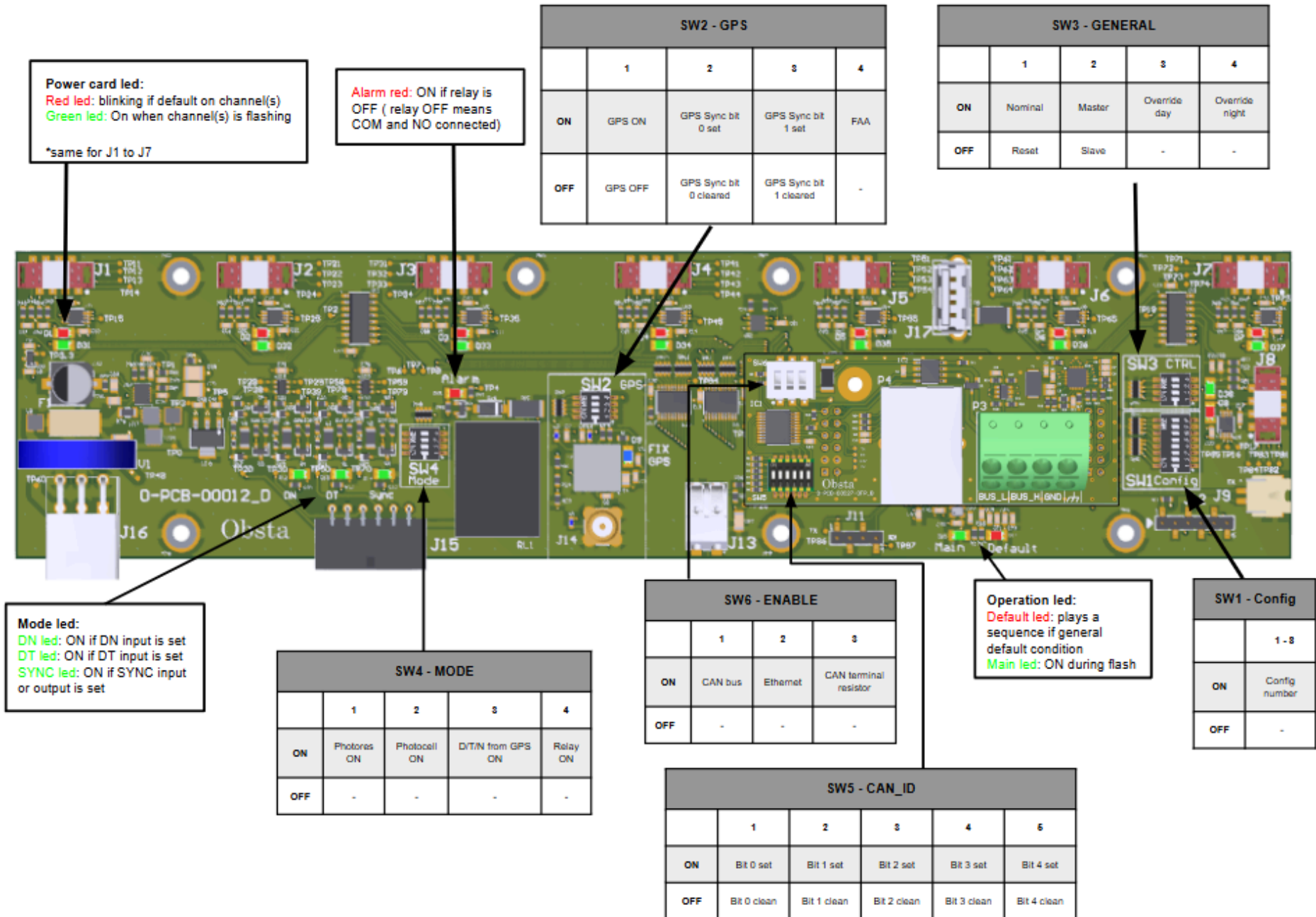

Errors when starting up the card

The following cases appear when the card is started up, when the configuration is incomplete, and prevent the program from running. **All the red leds on the power cards:**

- Flash at the same time if the programme is for production and the series number has not been programmed.
- Light up one after the other if Ethernet is enabled but the IP address has not been configured.

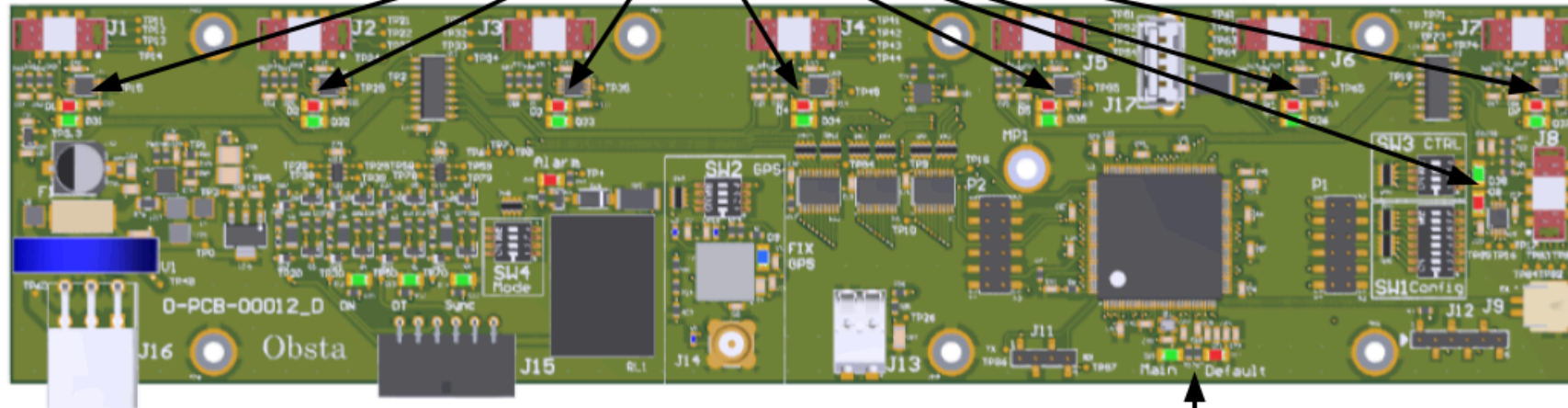

During a firmware update via USB → IP address configuration

- The copy of the logs onto a USB key went well
- The new software was copied to the card successfully
- Alternating * and * (x12) The IP configuration was correctly done

Possible error sequence

- - - Error mounting the file system
- - - Error in the format of the ip.cfg file
- Empty USB key
- - - Error opening MI.bin file
- - - Error while waiting for write access to flash memory
- - - Error during MI.bin file reading (Input/output error or invalid file size)
- - - Error decrypting the MI.bin file
- - - Error writing MI.bin file to flash memory
- - - CRC incorrect (this error may be caused by an incorrect encryption key).
- - - Error during mi_log.bin file encryption
- - - Error when writing the mi_log.bin file
- Error when unmounting the file system (this event is reported AFTER the USB key has been removed, for 10sec)
- - - Error processing USB events: unexpected event

Operation led: 2 leds are present to inform about operation status. See default section for more information.

In operating conditions

- Power supply voltage problem
- .-. Configuration is invalid
- .. Default mode activated due to channels errors
- . Relay activated due to channels errors
- . Slave out of synchronization (no TOP SYNCHRO received)
- .-. GPS out of synchronization
- ... HIFAA internal communication problem (between the two PCB)
- . Day/Twilight/Night mode unchanged (since 48 hours)
- .-. External (CAN or Ethernet) communication problem
- GPS lost synchronization since less than 15 minutes

As flash

During USB firmware update process

- Log retrieval has been processed successfully
- Software update has been processed successfully

In any other case, a specific sequence will be played on Default led, refer to SRS (Software Requirement Specification) for details.

Power card led: 7 pairs of 2 led indicators are present to inform about the operation status of each power card (J1 to J7).

- . short circuit
- . full open-circuit
- .-. full regulation problem
- full regulation problem
- . . one channel regulation problem

Mode led: 3 leds are present to inform about synchronization and “Mode” information
Top sync blink at each lamp flash in master configuration or at each flash request received from the controller.

DT: for twilight mode (depending on switch 4 configuration and model).

DN: for night mode (depending on switch 4 configuration and model).

Switch: They are present to allow multiple kind of operation:

- SW1: Select the topology and the associated configuration (FPM, Flash frequency, etc...)
- SW2: Set the synchronisation with GPS
- SW3: Control (lamp ON/OFF, master slave ...)
- SW4: Set switch sensor is used for mode change (Day, Twilight, Night)

For more information about switches see the dedicated section.

USB port: A USB port is available on the PCB (PJ16), allowing to connect a mass storage device and process:

- a firmware update;
- a log retrieval operation
- TCP/IP configuration

The USB device may not be used without Obsta's consent.

USB default code (in the following may order):

Error condition	Default led sequence
Error when mounting USB file system.	— · — 1 long, 1 short and 1 long
Error parsing an “ip.cfg” file.	— — — · 2 long and 2 short
USB key is empty, no log file, no firmware, no IP configuration detected.	· 1 sort
Error when opening an “MI.bin” file.	— · 1 short and 1 long
Error waiting for flash memory write access.	— · · 1 long and 2 short
Error when reading “MI.bin” file.	— · · · 1 long and 3 short
Error when decrypting “MI.bin” file.	· — 1 short and 1 long
Error when writing “MI.bin” file to flash memory.	· · — 2 short and 1 long
Incorrect CRC result.	· · · — 3 short and 1 long
Error when encrypting “mi_log.bin” file.	· · 2 short
Error when writing “mi_log.bin” file.	· · · 3 short
Removing the USB key during playback (after a 10sec delay).	— 1 long
Error when processing USB event: unexpected event.	— — 2 long

4.1.5 Power card (O-PCB-00015-0FP)

The power supply unit includes 8 power cards per block. Those cards regulate the current of 16 led circuits, 2 per PCBa (Depending on the installation).

The 8 power cards drive the white (or red/IR) led circuits inside each projector.

For white configuration: each card is affected by the associated projector number on the interconnection board. the power cards #1 to #8 are associated to white led circuits inside projectors from left to right (PJ1 → Power card #1, PJ2 → Power card #2 ... PJ8 → Power card #8). One power card for one white projector.

For red configurations: the red and infrared circuits of the projectors are connected in series. Unlike “white” connections, one power card can control several red and/or infrared projectors.

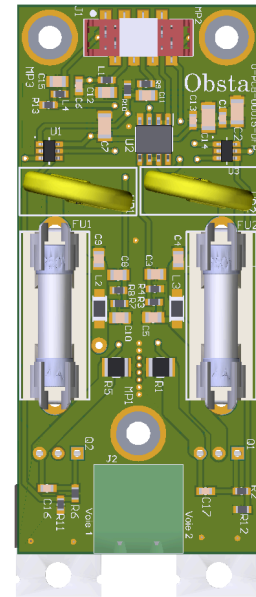

4.1.6 Alimentation card (O-PCB-00038-0FP)

The alimentation card is used to connect two power supplies (MEANWELL-HLG-480H-48A) to the system. It is therefore only used for 240Vac models.

Do not modify any factory preset or cabling without Obsta consent.

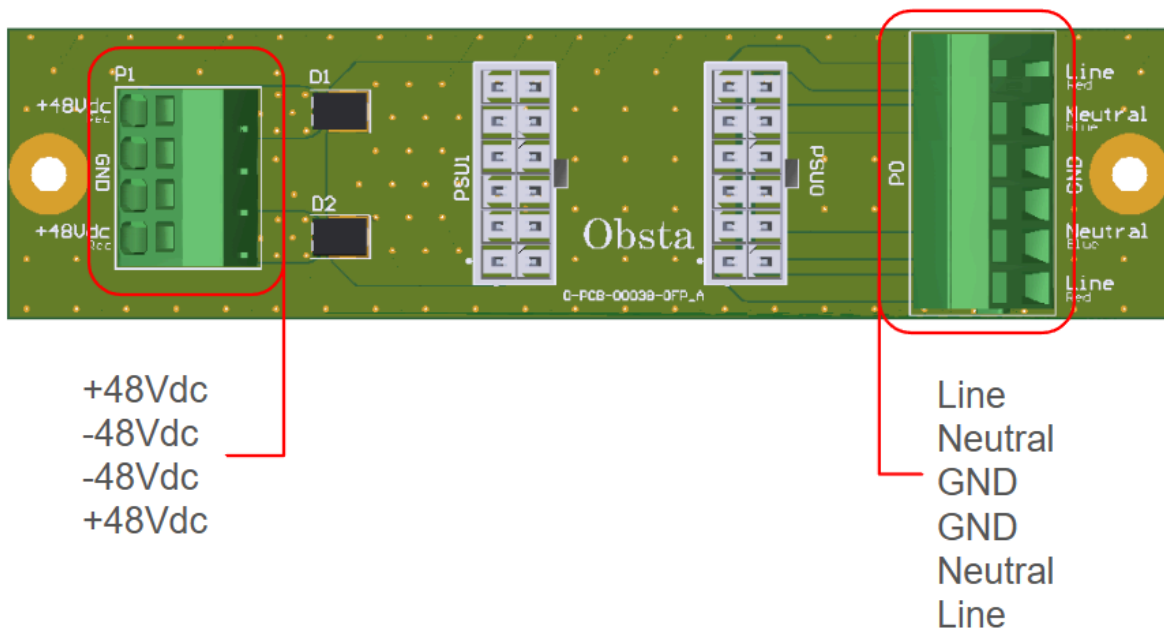

4.5 Internal Wiring

All cards are connected by cable harness. There are 4 harnesses in total:

- AC Power harness → From Interconnection to Power Supply card
- DC Power harness → From Interconnection to Power supply card
- Signal Harness → From Interconnection to Command card
- Projector Harness → From Interconnection to Power card (1 to 7)

All harnesses are installed in the OBSTA factory. If any operation is needed, please contact OBSTA before any intervention. Harness must be manipulated with care, do not pull the harness by the wire. Avoid using tools (Screwdriver) for removing connectors from the card, this could damage the harness or the card.

As a reminder:

- For the 240Vac version, the wiring between the interconnection card and power supply is the same for all versions (1B, 2B, 3B, 4B).
- The interconnection card is different between 1B and 2B, 3B, 4B version
- For 2B, 3B, and 4B, there is an additional generic card.

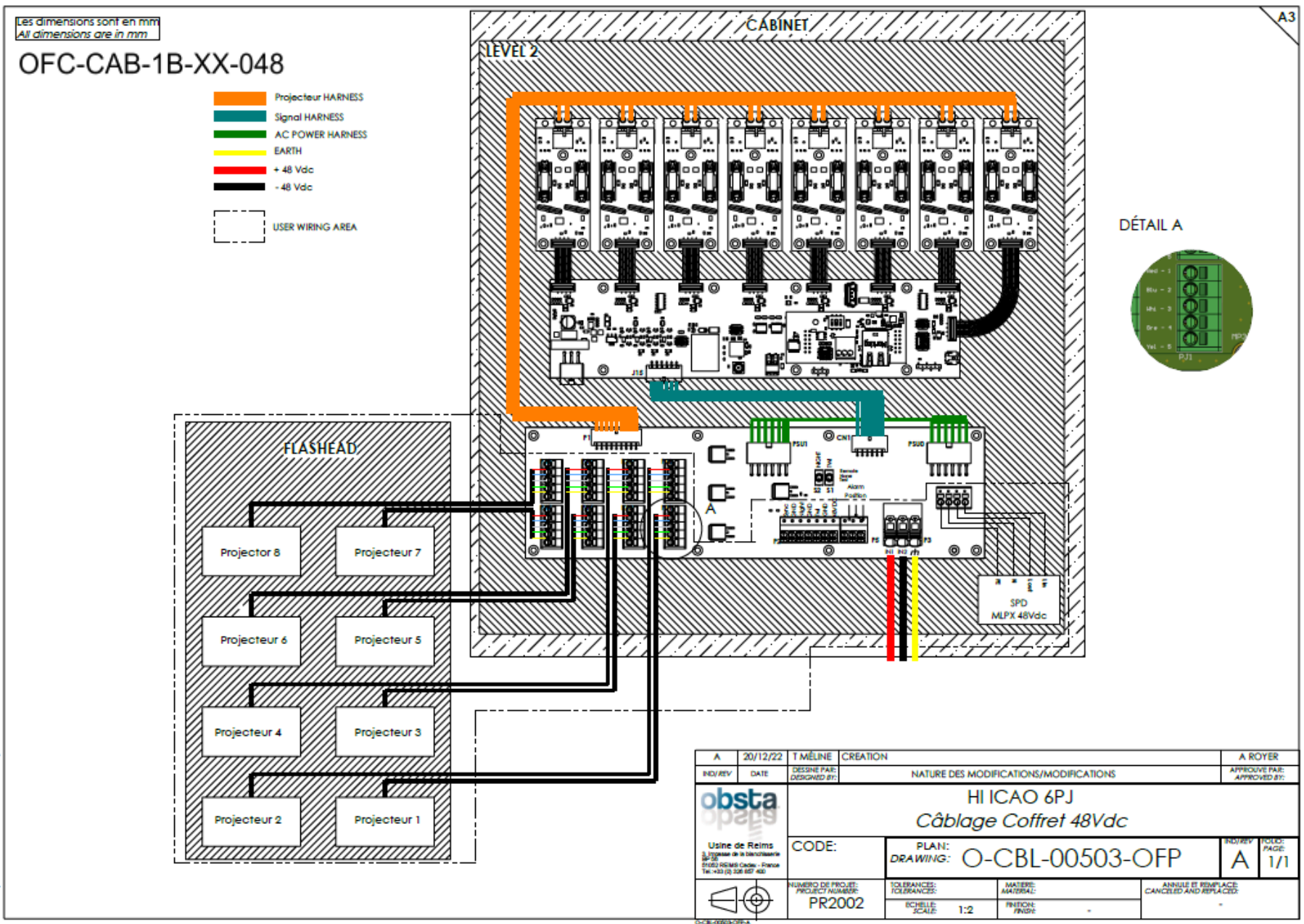

This drawing & covers are the property of OBSTA. This document cannot be reproduced, copied or communicated with third parties without the authorization of OBSTA.
 Ce document est la propriété d'OBSTA. Il ne peut être reproduit ou communiqué à des tiers sans l'autorisation écrite d'OBSTA.
 Seul le plan PDF est contractuel. Only the PDF Draw is contractual.

Les dimensions sont en mm
All dimensions are in mm

OFC-CAB-1B-XX-240

- Projecteur HARNESS
- Signal HARNESS
- AC POWER HARNESS
- DC POWER HARNESS
- EARTH
- LINE
- NEUTRAL

USER WIRING AREA

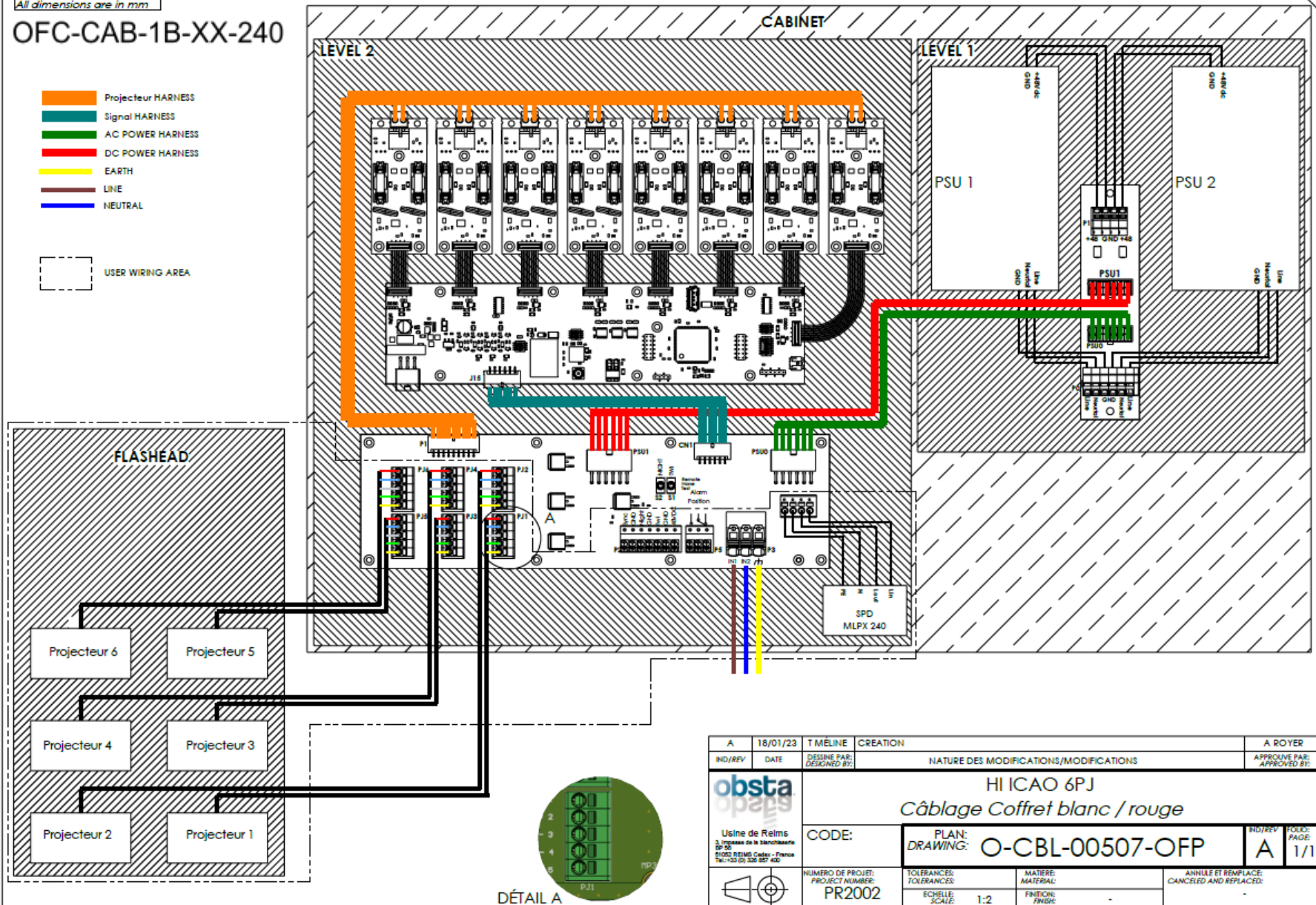

This drawing is the property of OBSTA. This document cannot be reproduced, copied or communicated with third parties without the authorization of OBSTA.
 Ce document est la propriété d'OBSTA. Il ne peut être reproduit ou communiqué à des tiers sans l'autorisation écrite d'OBSTA.
 Seul le plan PDF est contractuel. Only the PDF Draw is contractual.

A	18/01/23	T MÊLINE	CREATION	A ROYER
IND/REV	DATE	DÉSSINE PAR: DESIGNED BY:	NATURE DES MODIFICATIONS/MODIFICATIONS	APPROUVE PAR: APPROVED BY:
obsta opaps		HI ICAO 6PJ Câblage Coffret blanc / rouge		
Usine de Reims 3 Impasse de la Blanchisserie BP 20 51092 REIMS Cedex - France Tel: +33 (0) 328 957 400		CODE:	PLAN: DRAWING: O-CBL-00507-OFF	IND/REV PAGE: A / 1/1
NUMÉRO DE PROJET: PROJECT NUMBER: PR2002		TOLERANCES: TOLERANCES: ECHÈLE: SCALE: 1:2	MATÉRIEL: MATERIAL: FINITION: FINISH:	ANNULÉ ET REMPLACÉ: CANCELED AND REPLACED:

DÉTAIL A

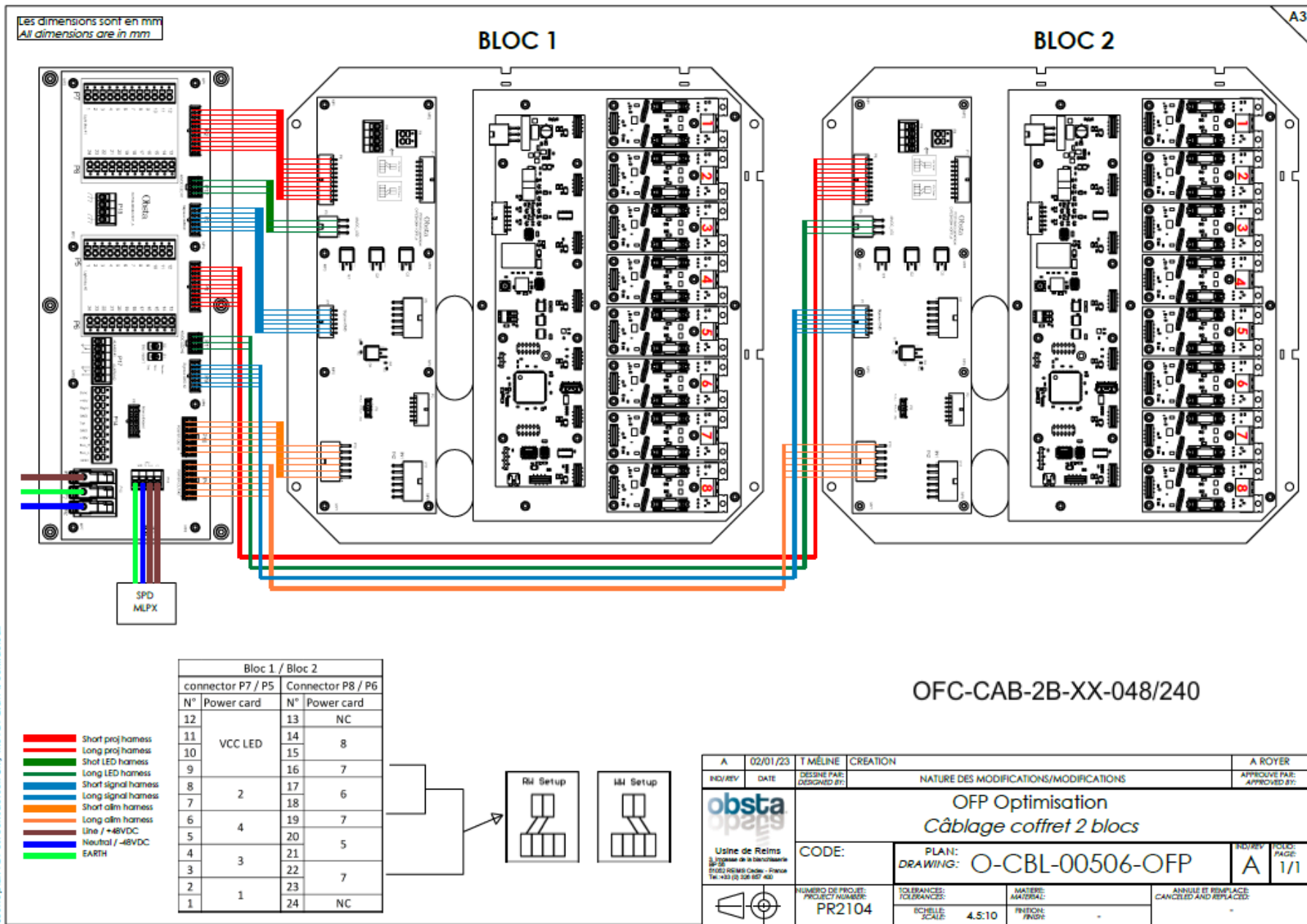

This drawing is the property of OBSTA. This document cannot be reproduced, copied or communicated with third parties without the authorization of OBSTA.
 Ce document est la propriété d'OBSTA. Il ne peut être reproduit ou communiqué à des tiers sans l'autorisation écrite d'OBSTA.
 Seule la version PDF est contractuelle. Only the PDF Draw is contractual.

Les dimensions sont en mm
All dimensions are in mm

A3

BLOC 1

BLOC 2

OFC-CAB-3B-XX-048/240

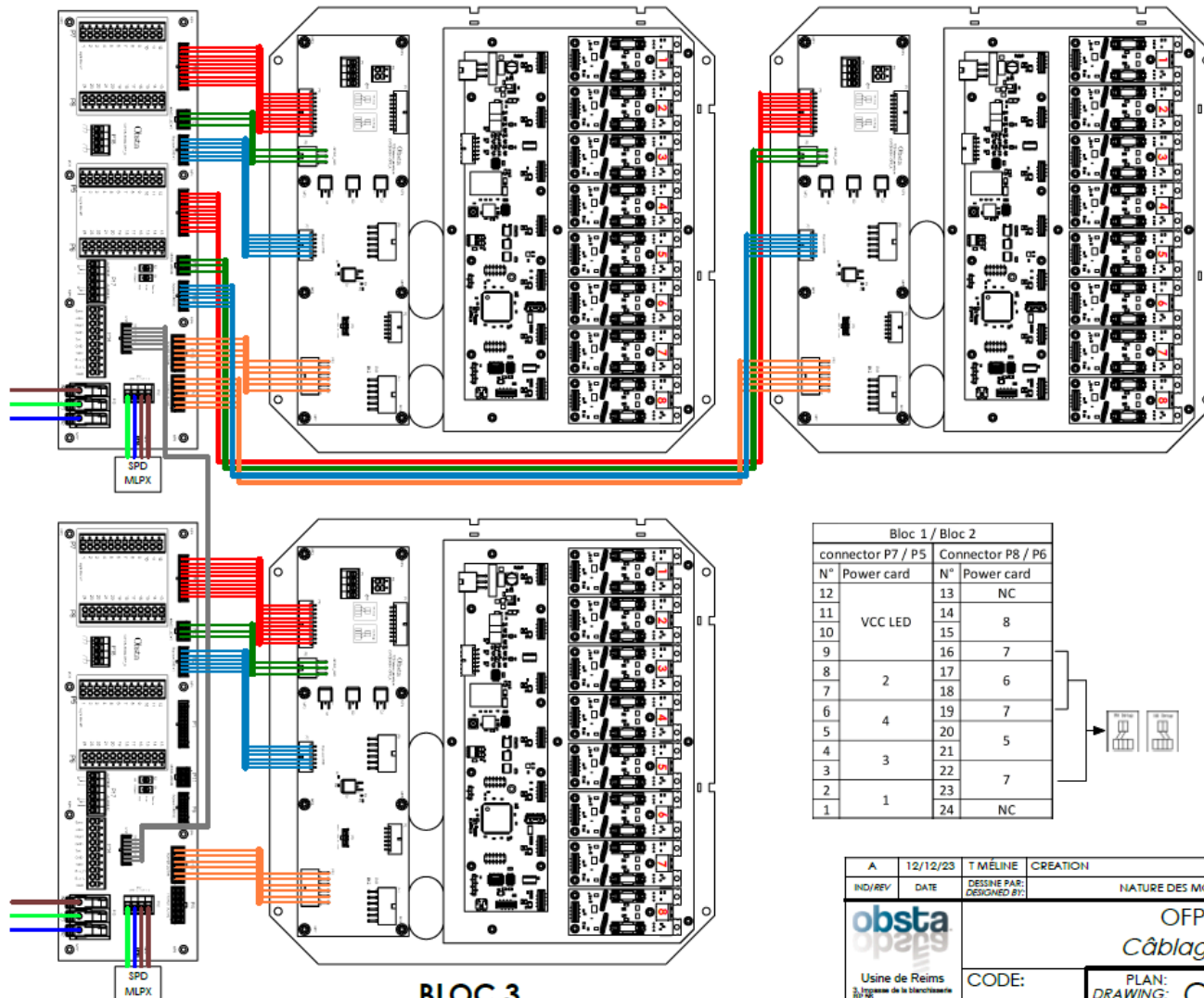

- █ Short proj harness
- █ Long proj harness
- █ Short LED harness
- █ Long LED harness
- █ Short signal harness
- █ Long signal harness
- █ Short aim harness
- █ Long aim harness
- █ Inter to inter harness
- █ Line / +48Vdc
- █ Neutral / -48Vdc
- █ EARTH

Bloc 1 / Bloc 2		Bloc 3	
connector P7 / P5	Connector P8 / P6	connector P7	Connector P8
N° Power card	N° Power card	N° Power card	N° Power card
12	13 NC	12	13 NC
11	14	11	14 VCC LED
10	15 8	10	15 8
9	16 7	9	16 7
8	17 6	8	17 6
7	18 6	7	18 6
6	19 7	6	19 7
5	20 5	5	20 5
4	21 7	4	21 7
3	22 7	3	22 7
2	23 NC	2	23 NC
1	24 NC	1	24 NC

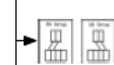

This drawing is the property of OBSTA. This document cannot be reproduced, copied or communicated with third parties without the authorization of OBSTA.
 Ce document est la propriété d'OBSTA. Il ne peut être reproduit ou communiqué à des tiers sans l'autorisation écrite d'OBSTA.
 Seul le plan PDF est contractuel. Only the PDF Draw is contractual.

A	12/12/23	T MÉLINE	CREATION	A ROYER
IND/REV	DATE	DESSEIN PAR: DESIGNED BY:	NATURE DES MODIFICATIONS/MODIFICATIONS	APPROUVE PAR: APPROVED BY:
		OPF Optimisation Câblage Coffret 3 blocs		
Usine de Reims 3, rue de la Bièvre 51102 REIMS Cedex - France Tel: +33 (0) 326 987 400		CODE: PLAN: DRAWING: O-CBL-00511-OPF	IND/REV A	FOLIO/ 1/1
NUMERO DE PROJET: PR2104		TOLERANCES: TOLERANCES: - ECHELLE: SCALE: 1:3	MATIERE: MATERIAL: - FINITION: FINISH: -	ANNULE ET REMPLACE: CANCELED AND REPLACED: -

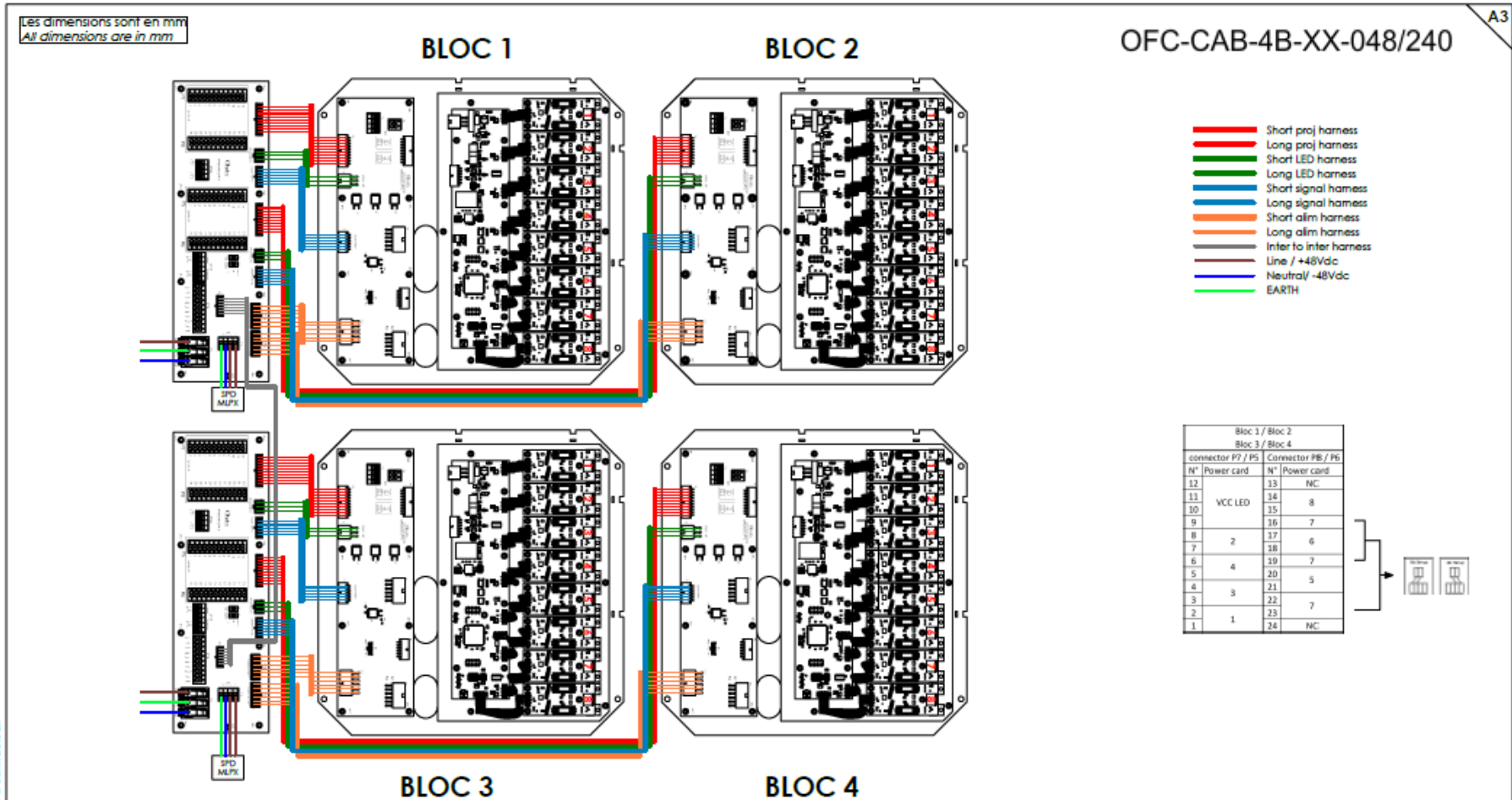

This drawing & covers are the property of OBSTA. This document cannot be reproduced, copied or communicated with third parties without the authorization of OBSTA.
 Ce document est la propriété d'OBSTA. Il ne peut être reproduit ou communiqué à des tiers sans l'autorisation écrite d'OBSTA.
 Seulement le PDF est contractuel. Only the PDF Draw is contractual.

A	18/12/23	T M ÉLINE	CREATION	A ROYER
REV	DATE	DESIGNER	NATURE DES MODIFICATIONS/MODIFICATIONS	APPROVED BY:
		OFF Optimisation Câblage Coffret 4 blocs		
Usine de Reims 11 rue de la République 51100 REIMS Cedex - France Tel: +33 (0) 326 857 400		CODE:	PLAN: O-CBL-00512-OFF	REV: A PAGE: 1/1
		NUMERO DE PROJET: PR2104	TOLERANCES: - ECHELLE: 1:4	MATERIE: - FINITION: -
		ANULER ET REMPLACER CANCELED AND REPLACED		

5. Operation

5.1 Switches configuration

5.1.1 SW1-Configuration

Configuration is set in the factory as the topology of the systems.

Changing the switches without Obsta approval may cause irreversible damage either to the lamp or the power supply.

5.1.2 SW2-GPS

Configuration of the GPS (**GPS antenna with 5m RG174 SMA male**) for flash synchronization (the SW3 must be set to master).

N°	1	2*	3*	4
ON	GPS used	Sync 0.0	Sync 1.0	ORD → Override the mode and force it into Day mode
OFF	GPS not used	Sync 0.1	Sync 1.1	ORN → Override the mode and force it into Night mode

*2 (Sync 0)	*3 (Sync 1)	Comment
OFF	OFF	Flash sequence start at the second "0" of watch minute
OFF	ON	Flash sequence delayed by 1/13 th of period from second 0
ON	OFF	Flash sequence delayed by 3/13 th of period from second 0
ON	ON	Flash sequence start at the second "1" of each minute

If the system is using external signals for synchronization, in case of defect of signal, the GPS is automatically used for the flash and day/twilight/night mode:

- Flash synchronization is done as per dip-switches 3 and 4 on SW2
- Day/Twilight/Night mode is done as per astronomical twilight (the sun is -6° below the horizon)

5.1.3 SW3 - Control

N°	1	2	3*	4*
ON	Operation	Master	ORN - 0.0	ORD - 1.0
OFF	Reset	Slave	ORN - 0.1	ORD - 1.1

- ORD → Override the mode and force it into Day mode
- ORN → Override the mode and force it into Night mode
- ORT (ORN + ORD) → Override the mode and force it into Twilight mode

*3(ORN)	*4 (ORT)	Comment
OFF	OFF	-
OFF	ON	ORD
ON	OFF	ORN
ON	ON	ORT

5.1.4 SW4 - Mode

This switch selects which sensor is used on the product:

N°	1	2	3*	4*
ON	Photores (detected if D/T/N)	External	GPS	Alarm used
OFF	-	-	-	Alarm not used

5.2 Default

5.2.1 Operation led

	Default	Condition	Red led signal	Lamp signal
D0	Power supply voltage	Detected if there is a power supply issue (Over-voltage or under-voltage) short and continuous blinking	OFF
D1	Invalid configuration	Means inconsistency in dip-switches, for any of the following reasons: <ul style="list-style-type: none"> • GPS is disable an Sync 1 + Sync 0 are set • Several sensor for switching mode are set • The selected configuration number does not exist 	---- 1 long and 3 short	OFF
D2	Power card default error	Default from either Power card or projector causing insufficient light	.. 2 short	-
D3	Light channels relay error	Default from either power card or projector causing insufficient light	. 1 short	-
D4	GPS out of synchronization	GPS is in used and no signal accurate is received	--- 1 long and 2 short	15 FPM
D5	Slave out of synchronization	Card in slave mode and no synchronization signal during 10sec	--- 1 long and 1 short	15 FPM
D6	D/T/N mode unchanged	The mode did not change since the last 48 h	--- 1 long	-
D7	External communication problem	Communication though Ethernet or CAZN date link has failures	--- 2 long	-
D8	GPS default	If GPS is out of synchronization but has been synchronized since last 15 minutes: working on internal clock	Same as Lamp flash	-

The "lamp signal" column indicates if the activation of a given default modifies the current sequence of currently activated mode (When "OFF" is specified, it means that no flash shall occur).

This sequence shall last until corresponding default is cleared, and if several defaults are present, only the sequence of highest priority default shall be applied.

5.2.2 Power card led

Power card error	Error condition	Persisted	Power card default led sequence
Short circuit	Some or all led are not working	NO	• 1 short
Open circuit 1	Both led circuit piloted by the power card are in open circuit	NO	•— 1 short and 1 long
Current regulation issue 1	Power card cannot set the according current on both circuit led	YES	•— 1 short and 2 long
Open circuit 2	One of the two led circuit piloted by the power card is in open circuit	NO	— Same as lamp flash
Current regulation issue 2	Power card cannot set the according current on one circuit led	YES	— Same as lamp flash and follow by 1 short

5.2.3 Alarm

Alarm will be set when some conditions are met, depending on the configuration and switches. (Only activate if switch 3.4 is set).

Alarm errors are described in 6.3.1.

6. Installation

6.1 Unpacking

Carefully unpack each item and remove any internal packing material from the power supply and the lamp. Examine each item for obvious physical damage. Report any claims to the carrier immediately.

6.2 Mounting and preparation

Any manual intervention must be performed on a NON-POWERED product. Human or material issues could occur inducing injury or permanent damage to the product.

Depending on the application multiple flash units may be required. Obsta recommends that each unit has its own support (one supports the kit : Flashhead + Cabinet). Cabinet or Flashhead must be installed in a fixed position. OBSTA also recommends that the cabinet shall be in an easy access position/orientation for maintenance purposes. Each part of the kit must be correctly fixed to the structures.

The Cabinet must be levelled using a spirit level and the cable gland must face downwards. Cable shall be installed with cable clamp to avoid any oscillation movement due to wind pressure.

1. Verify that the mounting surface is free of debris.
2. Align the four mounting holes of the cabinet with the holes in the structure mounting plate. The cabinet has 4 holes 9 mm in diameter
3. Fit the screw of the cabinet loosely. Do not tighten up screws yet.
4. Ensure that the cabinet is installed horizontally by using the level provided (air bubble shall be centered).
5. If the cabinet is not leveled, add stainless steel shim material or washers (stainless steel or galvanized) as necessary to level the flash-head.
6. Once leveled, firmly secure the hardware once the cabinet, using the same torque on each screw. Verify that the cabinet is level when the hardware is fully tightened. If not leveled, then loosen the mounting hardware and repeat Step 5 until the beacon is firmly secured horizontally.

In some specific cases with high electromagnetic fields an additional shield is required to ensure proper operating. Obsta may provide or suggest additional equipment to improve stability and durability of the kit. Please contact Obsta if the product may be exposed to this kind of perturbation.

6.2 Cable gland installation

- Strip excess cable length to expose shielding.
- Leave 15mm of shielding, strip the rest.

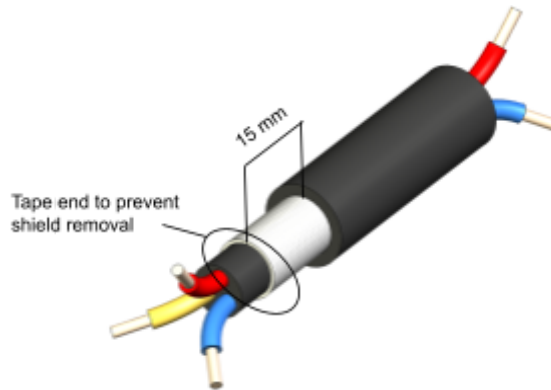

- Thread the cable through the cable gland (the ring is loosened but not removed) so that the shield is in contact with the gland springs. The gasket must be correctly

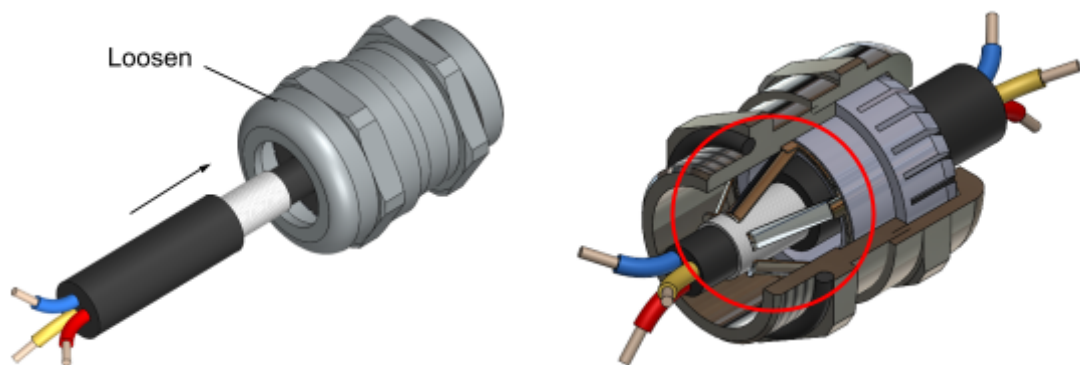

- Positioned flat and in its housing for optimum sealing.
- Tighten the gland ring with the appropriate wrench.
- Once the cable has been clamped in the cable gland, cut and strip the wires to the length required to connect the terminal blocks (don't forget to fit cable ferrules before connection).

CEM	Cable diam min (mm)	Cable diam max (mm)	Pressure nut wrench	Locknut wrench
M16	4.5	10	20	20
M20	7	13	24	24
M25	9	17	29	29
M32	11	21	36	36
M40	19	28	45	45

7. Maintenance

7.1 Annual visit

Test	Frequency	Preventive action	Risk
Wiring	Annual	Visual control Tightening cable glands Tightening PCB wires	Water infiltration Poor circuit Cable degradation
Waterproof	Annual	Visual verification Search the water leak	Water infiltration Short circuit Lamp in default mode (or light off)
Clamping	Annual	Checking tightness	Cabinet falling Water infiltration
Aspect (rust, dust...)	Annual	Exterior cleaning	Malfunction

Before opening the lamp and carrying out any work, check that there is no current in the cabinet.

7.2 Spare part

- COMMAND-CARD-48VDC-6P-RW [**113744B**]
- POWER CARD 48VDC [**113741B**]
- PCBa OFP MI CAN Extension Card [**770327**]
- PCBa 1 block Interco RW [**770334**]
- PCBa Interco 2 blocs [**770331**]
- PCBa Intercom multi blocks [**770332**]
- PCBa 1 block PSU [**770333**]
- Harness Wire Kit 1 bloc [**113760B**]
- MLPX 48
- MPLX 240

8. Typical wiring

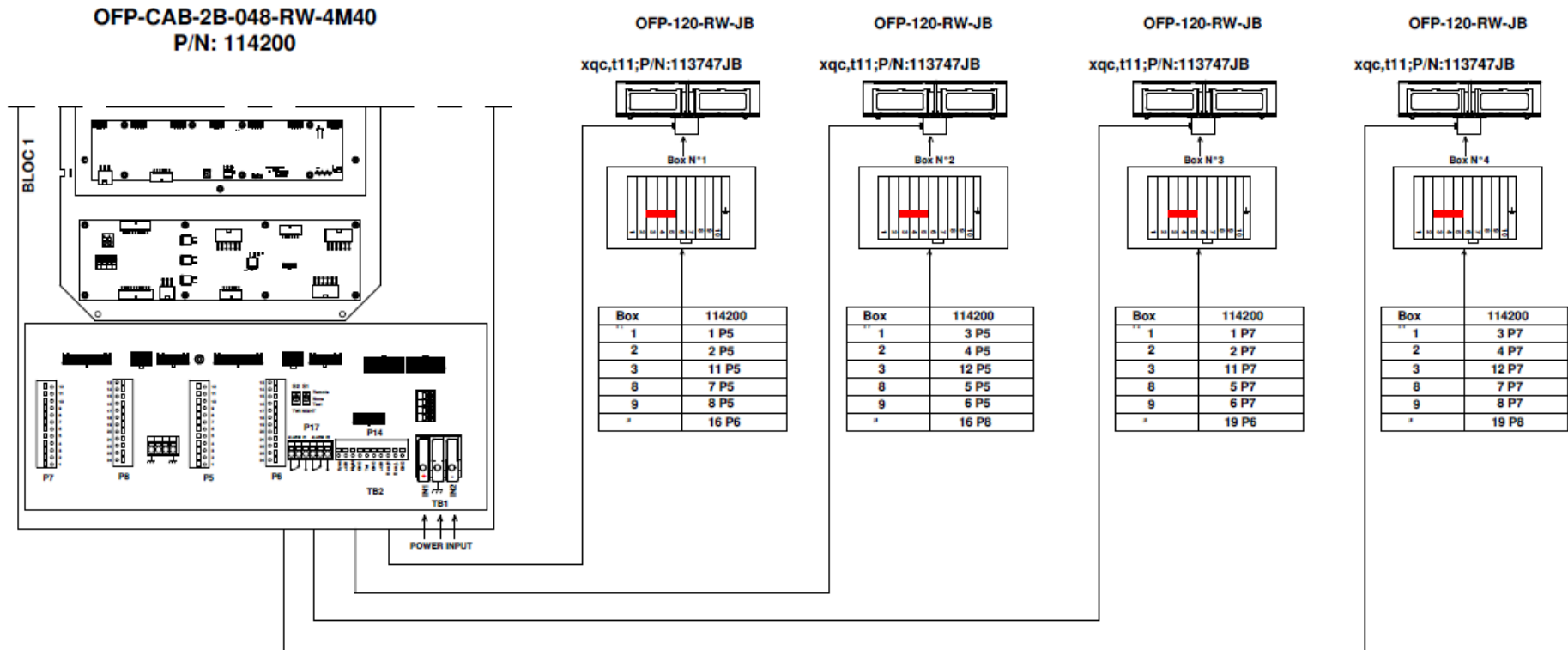

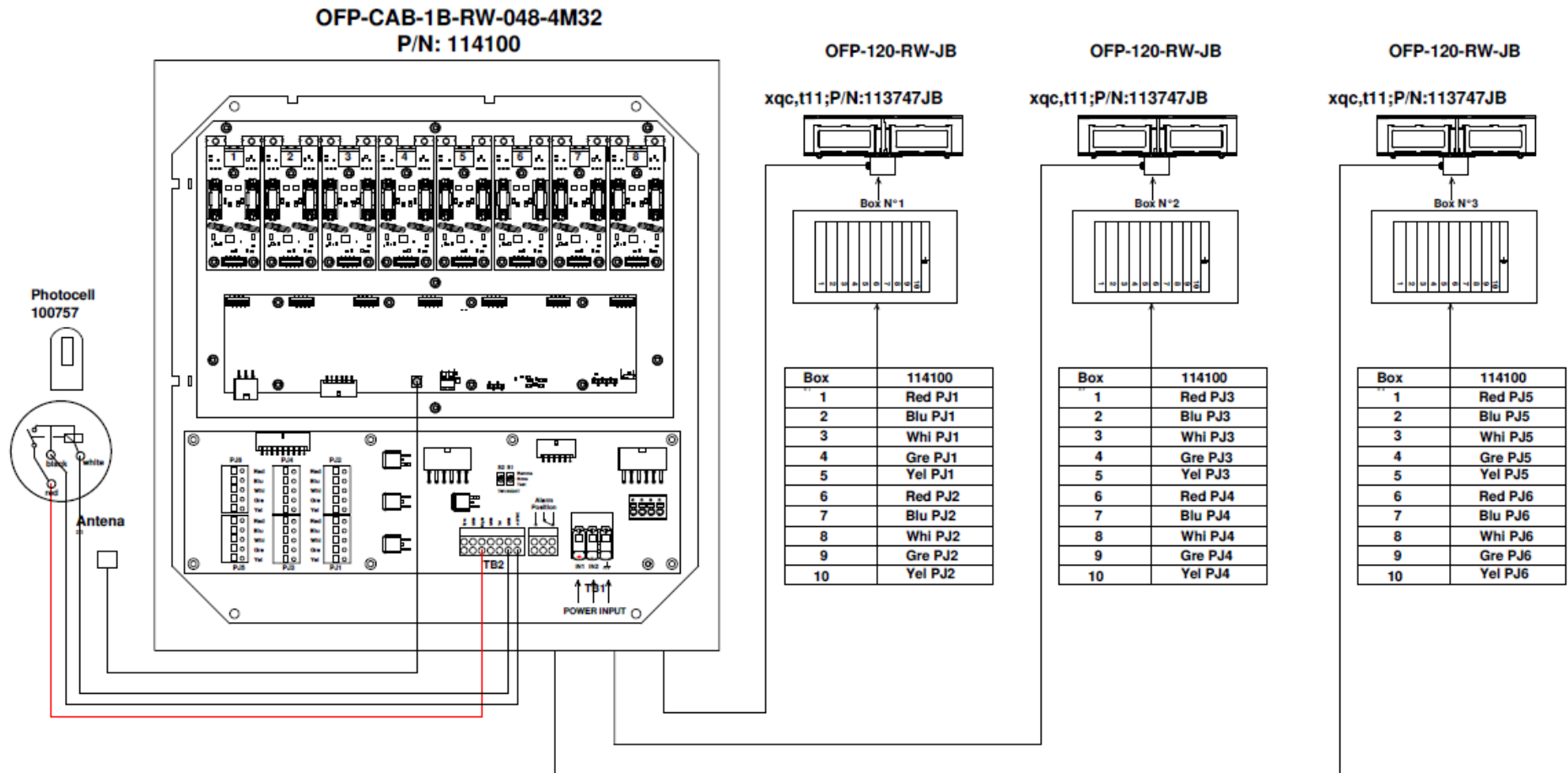

Obsta
3, impasse de la blanchisserie
51052 Reims CEDEX - FRANCE

This document is the property of OBSTA. It may not be reproduced or communicated to third parties without the written permission of OBSTA.

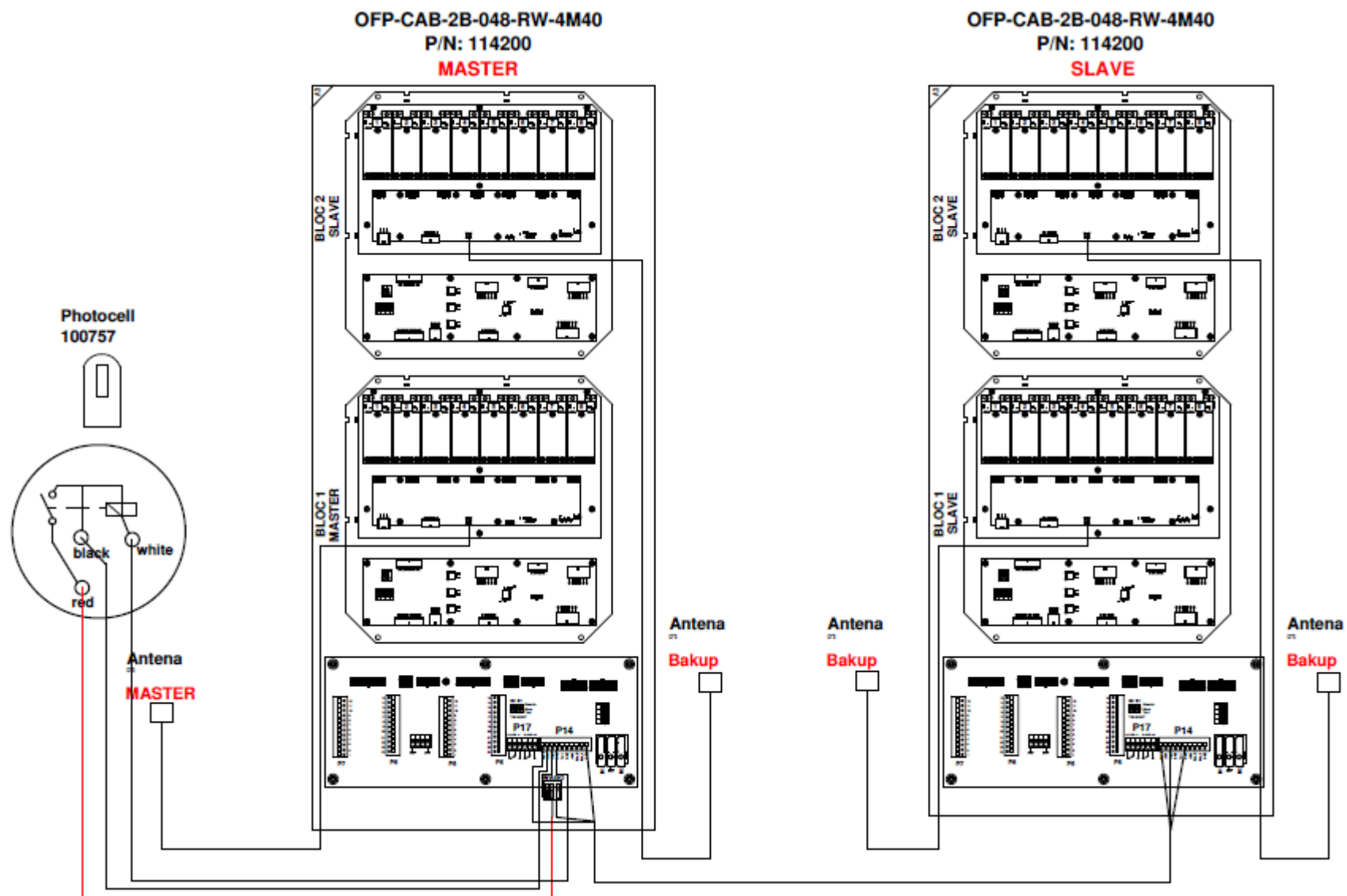

3, impasse de la blanchisserie
51052 Reims CEDEX - FRANCE