



NAVILITE-IR-FAA-120-240V // 113969IR
NAVILITE-IR-F-048V //113965IR





Obsta

3, impasse de la blanchisserie
51052 Reims CEDEX - FRANCE

This document is the property of OBSTA. It may not be reproduced or communicated to third parties without the written permission of OBSTA.

1. Product name and part number	3
2. Be careful	4
3. Warranty	5
4. General information:	6
4.1 Scope	6
4.2 General description	6
4.3 NAVILITE L-810(L) 048Vdc and L-810(L)(F) 240Vac	7
4.4 Bill of materials	8
4.6 beacon dimensions	9
5. Technical specification	10
5.1 Light output	10
5.2 Electrical input	10
5.3 Mechanical properties	11
6. Operation	12
6.1 System components	12
6.1.1 Flash head	12
6.1.2 The base	12
6.1.3 Shunt braid	12
6.2 Configuration	12
6.2.1 Switch configuration	12
6.2.2 Lamp reset	13
6.2.3 Loading configuration and master start-up	13
6.2.4 Loading configuration and slave start-up	13
6.3 Defects management	14
7. Installation	15
7.1 Unpacking	15
7.2 Mounting and preparation	15
7.2.1 Installation of the light	15
7.2.2 Electrical wiring inside the light	15
7.3 Checking during and after the installation	16
7.4 Mounting	17
7.4.1 NPT 3/4"	17
7.4.2 With bracket (P/N-113928)	17
7.4.3 Square and Ubolt (P/N-113789-NAV-XXX)	18
8. Maintenance	19
9. Default	20
10. Wiring	21

1. Product name and part number

Description	Norm	Power supply	Part number (P/N)	QR code
NAVILITE-IR-FAA-120-240V	Low intensity ICAO type A, B and E FAA L-810(L), L-810(L)(F) <i>ETL listed</i>	110-240 Vac	113969IR	
NAVILITE-IR-F-048	Low intensity ICAO type A, B and E FAA L-810(L), L-810(L)(F) <i>ETL not listed</i>	48 Vdc	113965IR	

2. Be careful



1. Do not proceed with any maintenance job when the light is under operation.
2. Power supply must be shut down when opening the product.
3. Installation must be performed only by an electrically skilled operator and National electrical installation rules must be respected.
4. . Do not look directly at the projector while it is in operation : Led projectors produce brilliant flashes of lights which can result in temporary or permanent eye damage.



3. Warranty

OBSTA warrants the equipment described in the instruction manual and sold to purchasers to be free from defects in material and workmanship at the time of shipment. OBSTA's liability under this warranty being limited to repairing or replacing, at OBSTA's option, items which are returned to it prepaid within twenty four (24) months from shipment to the original Purchaser, or twelve months from commissioning, and found, to OBSTA's satisfaction, to have been defective. In no event shall OBSTA be liable for consequential damages. NO PRODUCT IS WARRANTED AS BEING FIT FOR A PARTICULAR PURPOSE AND THERE IS NO WARRANTY OF MERCHANTABILITY.

This warranty applies only if: (I) the items are used solely under the operating conditions and in the manner recommended in OBSTA's instruction manual, specifications, or other literature; (II) the items have not been misused or abused in any manner or repairs attempted thereon; (III) written notice of the failure within the warranty period is forwarded to OBSTA and the directions received for properly identifying items returned under warranty are followed; and (IV) such return notice authorizes OBSTA to examine and disassemble returned products to the extent OBSTA deems necessary to ascertain the cause of failure. The warranties stated herein are exclusive.

THERE ARE NO OTHER WARRANTIES, EITHER EXPRESSED OR IMPLIED, BEYOND THOSE SET FORTH HEREIN, and OBSTA does not assume, nor does OBSTA authorize anyone else to assume for it, any other obligation or liability in connection with the sale or use of said products. OBSTA's liability on any claim of any kind, including negligence, for loss or damages arising out of or connected with the manufacture, sale, delivery, repair or use of any equipment or services provided by OBSTA shall in no case exceed the price allocable to the item or service or part thereof which gives rise to the claim.

The integrity and reliability of OBSTA aviation obstruction lighting systems is dependent on the use of OBSTA parts and components. To ensure the optimum performance and reliability of your OBSTA system, it is strongly advised that only components and modules manufactured by OBSTA be used.

4. General information:

4.1 Scope

This manual provides information about the installation, operation, and maintenance of the NAVILITE FAA Intensity Obstruction Lighting Systems manufactured by OBSTA. The lighting systems described in this manual are the 113969IR, low Intensity type A,B, E (ICAO) and FAA type L-810(L)(F) obstruction lights and the 113965IR, low intensity type A, B and E (ICAO).

4.2 General description

The NAVILITE FAA is an LED low intensity system manufactured to comply with ICAO annex 14 chapter 6 and Federal Aviation Administration Advisory Circular 150/5345-43J.

- ICAO low intensity type A, B or E with IR depending on internal switches positions.
- L-810(L) type red fixed with IR emissions (or L-810(L)(F) mimic with L-864 medium intensity) depending on internal switches positions (only 113969IR)).

The NAVILITE includes:

- A lamp molded with 8 level of leds, 7 red led and 1 IR led.
- A base with 2 x 3/4" NPT threaded holes for mounting.
- A NPT 3/4" plug (if one of the two threaded holes is not used).
- Intern PCB with switch (different configuration), Surge protection and alarm.
- A monobloc design with no loose part during installation

4.3 NAVILITE L-810(L) 048Vdc and L-810(L)(F) 240Vac

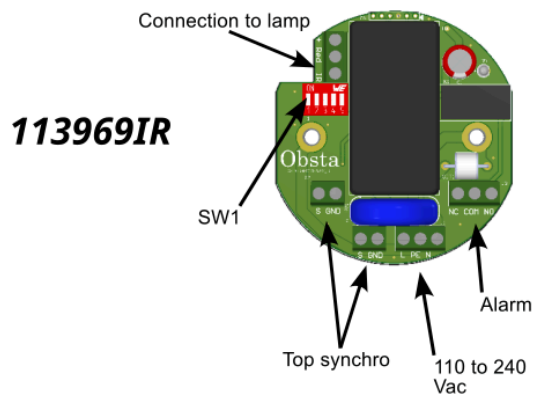
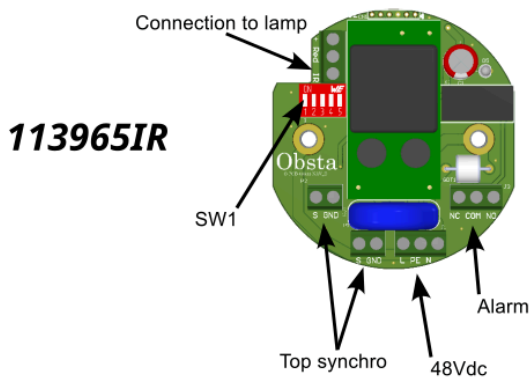
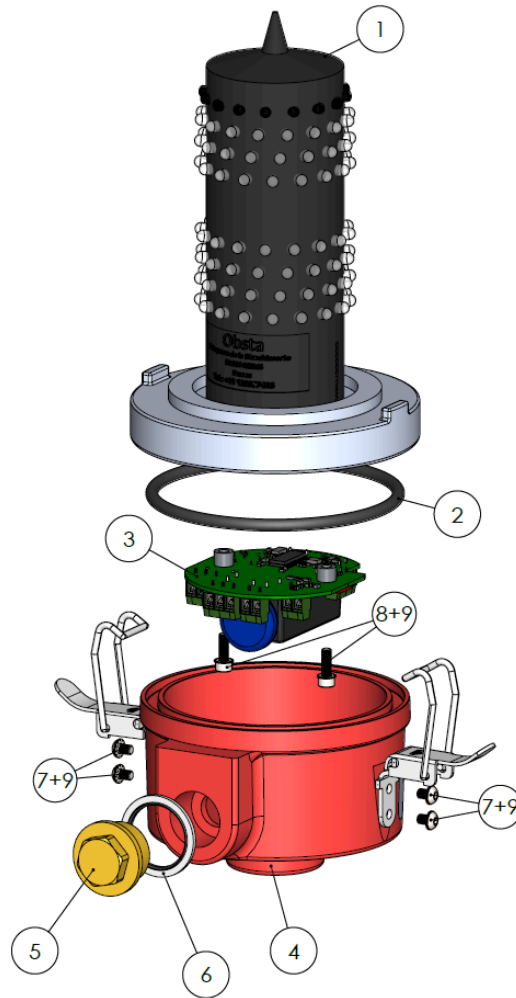

Obsta
 3, impasse de la blanchisserie
 51052 Reims CEDEX - FRANCE

4.4 Bill of materials

N°	DESCRIPTION	QTY	Spare part P/N
1	Navilite (lamp)	1	113960IR
2	O-ring Ø99x 5	1	
3	PCB Navilite	1	
(3a)	PCB Navilite 113965IR		113962IR
(3b)	PCB Navilite 113969IR		113961IR
4	Base	1	
5	$\frac{3}{4}$ " plug	1	
6	Gasket 3/4	1	
7	BHC M4x6 screw	4	
8	CHC M4x12 screw	2	
9	AZ M4 washer	6	

4.6 Beacon dimensions

A4

Les dimensions sont en mm
All dimensions are in mm
Ebavurage arêtes vives
Deburring sharp edges

This drawing if covers are the property of OBSTA. This document cannot reproduced, copied or cummunicated with third parties without the authorization of OBSTA. Ce document est la propriété d'OBSTA. Il ne peut être reproduit ou communiqué à des tiers sans l'autorisation écrite d'OBSTA.

Seul le plan PDF est contractuel / Only the PDF draw is contractual

A	09/12/24	T Oudin	CREATION	A ROYER
IND/REV	DATE	DESSINE PAR: DESIGNED BY:	NATURE DES MODIFICATIONS/MODIFICATIONS	APPROUVE PAR: APPROVED BY:
Navilite IR FAA				
<p style="font-size: x-small;">Usine de Reims 3, impasse de la blanchisserie BP 58 51052 REIMS Cedex - France Tel. +33 (0) 326 857 400</p>		CODE: 113969IR	PLAN: DRAWING: O-CUS-00696-NAV	IND/REV A
				FOLIO: PAGE: 1/1
		NUMERO DE PROJET: PROJECT NUMBER:	TOLERANCES: TOLERANCES: .	MATIERE: MATERIAL: -
		ECHELLE: SCALE: 1:3	FINITION: FINISH: -	ANNULE ET REMPLACE: CANCELED AND REPLACED: -

5. Technical specification

5.1 Light output

Name	Min	Nominal	Max	Unit
Luminosity IR	4	-	-	mW/sr
Luminosity RED	32.5	-	-	Cd
IR beam spread	-	>10	-	°
Red beam spread	-	>10	-	°
Beam pattern	-	360	-	°
Flash mode L-810(L)(F)	100	-	250	Flash duration (ms)
Fixed mode L-810(L)	-	Continuous	-	Flash duration

Synchronisation

- Master / slave mode (one master light can be synchronized with other slave lights), only for I-810(L)(F).

Alarm

- No power supply or power supply fail
- Visible or IR failure
- No synchronisation signal received in flash mode

To reset the alarm: switch off, then switch on again after 1 minute.

5.2 Electrical input

Name	Min	Nominal	Max	Unit
Voltage (113965IR)	25	48	60	Vdc
Voltage (113969IR)	90	110-240	277	Vac
Voltage synchro input	12	-	60	Vdc
Top synchro duration	2	-	100	ms

5.3 Mechanical properties

Weight

- 1.150Kg

Size

- 154x128.5x251mm

Attachment

- ¾ NPT
- x4 M4

5.4 Operating environment

Name	Min	Nominal	Max	Unit
Wind load	-	-	320	km/h
Humidity	5	-	95	%
Operating temperature	-40	20	+55	°C

6. Operation

6.1 System components

6.1.1 Flash head

The lamp comprises 2 stages with 7 red LED discs and one infrared LED disc.

6.1.2 The base

The red base contains the pcb (for 48 or 240 volts) which will manage the lamp. The red base can be connected with 3/4' NPT holes or with x4 M4 holes.

Installation must be carried out using a spirit level to ensure that the NAVILITE is perfectly horizontal and complies with the standard.

6.1.3 Shunt braid

The lamp is attached to the light body through a shunt braid. The shunt braid ensures the grounding of the light and prevents losing the lamp during installation.

6.2 Configuration

6.2.1 Switch configuration

The setting of the light is done through the switch on the command card (see SW1 page 7)

N°switch	1	2	3	4	5
ON	Nominal	Master	Duration	Duration	Duration
OFF	Reset	Slave	Duration	Duration	Duration

Switch number			Flash time
3	4	5	-
off	off	off	100 ms
off	off	on	125 ms
off	on	off	150 ms
off	on	on	175 ms
on	off	off	200 ms
on	off	on	225 ms
on	on	off	250 ms
on	on	on	Continuous

6.2.2 Lamp reset

If dipswitch contact 1 is OFF, the programme switches to reset mode:

- Previous fault conditions are cleared
- The lamp is off
- Alarm is engaged
- The error indicator (Red LED on PCBa) is lit.

6.2.3 Loading configuration and master start-up

If switch n°1 is ON (Nominal mode) and switch n°2 is ON (Master), the programme switches to master and nominal mode. In this mode, except in the event of an issue :

- Alarm is disengaged and the error led is off.
- The lamp turns on according to the selected sequence by switch n°3,4 and 5.
- If the light does not flash continuously, a 12 volt DC edge lasting 100 ms is output at the SYNC_OUT output, starting at the same time as the flash.

Note: When there is no alarm, a connection is established between COM and NC; when it is, a connection is established between COM and NO. The alarm is engaged to signal a default.

6.2.4 Loading configuration and slave start-up

If switch 1 is ON (Nominal mode) and switch 2 is OFF (Slave), the programme switches to slave and nominal mode.

In this mode, if there is a synchronisation fault, if the sequence selected is not a continuous flash and no other issue :

- The headlamp flashes at 15 FPM of 200ms.
- If at least a 2ms signal is detected on the "SYNC_IN" input (12 or higher or from another lamp), the synchronization default is cleared.

If no fault is present, or if the sequence is a continuous flash:

- The alarm is disengaged,
- The connected lamps light up,
 - Continuously if the selected sequence is a continuous flash.
 - Otherwise, whenever an incoming signal is detected on the "SYNC_IN" channel with a duration of 2 ms (or longer, from another light) and for the duration selected via the flash duration dipswitches.
 - This edge will be ignored if it occurs again while a flash is in progress and until 200ms after this flash.

6.3 Defects management

The light manages fault conditions (short-circuits, LED failure, etc.), resulting in certain warning behaviours and also affecting its main function (flashes).

Fault conditions are tested regularly and can be automatically cleared once the situation disappears. Except for lamp dysfunction default the status is retained until the reset of the product.

Description	Condition of default	LED pattern
Power supply	under or overvoltage	Short signal
Lamp dysfunction	Lamp 25% intensity loss	Signal at the same time as the flash
Slave synchronization	The light is in slave mode, the sequence of the active channel is not a continuous flash and the master light signal expected on "SYNC_IN" input has not been received within 10 seconds.	Long signal followed by a short signal

The relay switches-off when one or more of these faults are present.

When several faults are present at the same time, the LED displays the most important one (the table above lists them in order of priority).

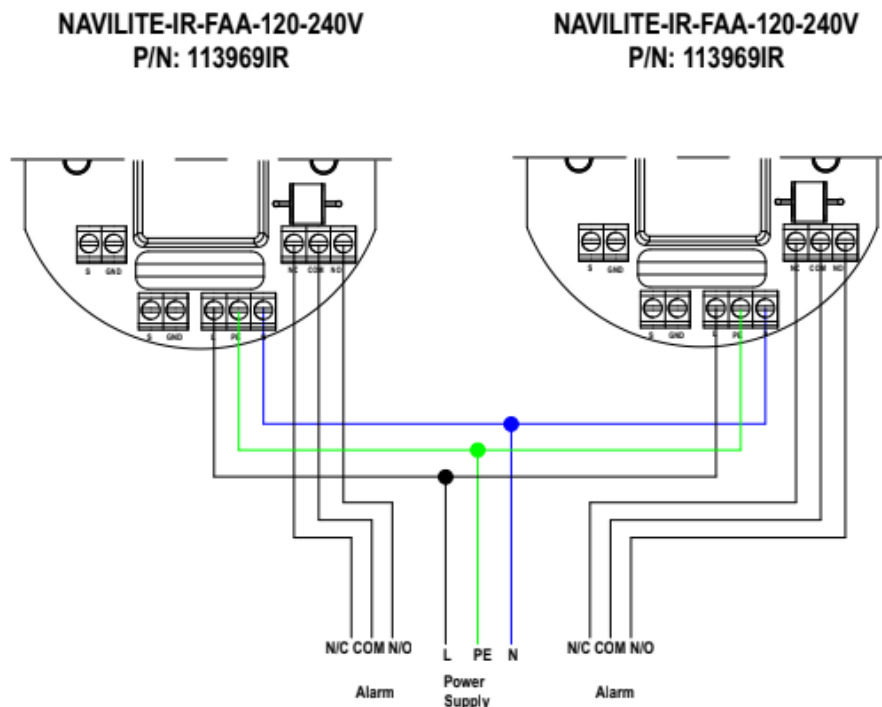

7. Installation

7.1 Unpacking

Carefully unpack the product and remove any internal packing material. Examine each item for obvious physical damage. Immediately report any claims to the carrier. Installation drawings are included in the power supply carton.

It's strongly recommended to supply the product and verify that it's working properly at ground level before final installation.

7.2 Mounting and preparation

7.2.1 Installation of the light

The light assembly fixture must be mounted perfectly horizontally to meet the optical specification required for Aircraft Obstruction lights. If mounted in another position, the fixture will not be considered as an Aircraft Obstruction lights.

Leveling of the light is the explicit responsibility of the installation. Installers must use a spirit leveler.

- 3/4" NPT pipe mounting : , leveling must be performed on the tube either horizontally or vertically.
- 4 M4 holes : leveling must be performed on the bottom of the light

We strongly advise that the metallic base of the light be connected through a grounding kit to the local grounding of the tower.

7.2.2 Electrical wiring inside the light

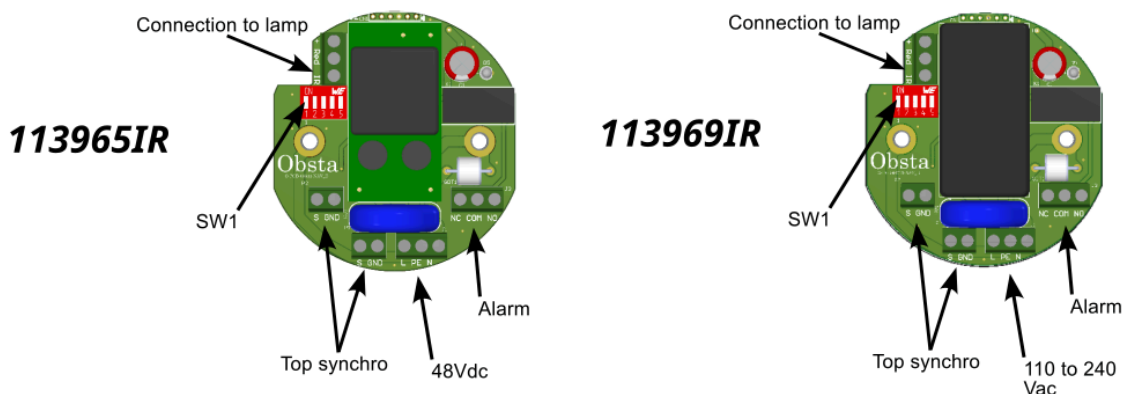

7.3 Checking during and after the installation

- Open the beacon base by using the two latches
- Check the internal wiring before fixing the lamp.
- Use wire end ferrules
- Check the power cable on the terminal connection
- Check the ground is connected on the terminal connection
- Check the synchronisation cable (if used)
- Check the position of the O-ring before closing the flash head and make sure the box is closed with the 2 latches. Incorrect tightening or positioning of the gasket can alter the tightness and cause irreversible damage to the NAVILITE.
- Use spirit level to check the light is perfectly horizontal.

Installation must check the wiring and the above points to ensure a good operation of the light and waterproof.

7.4 Mounting

7.4.1 NPT 3/4"

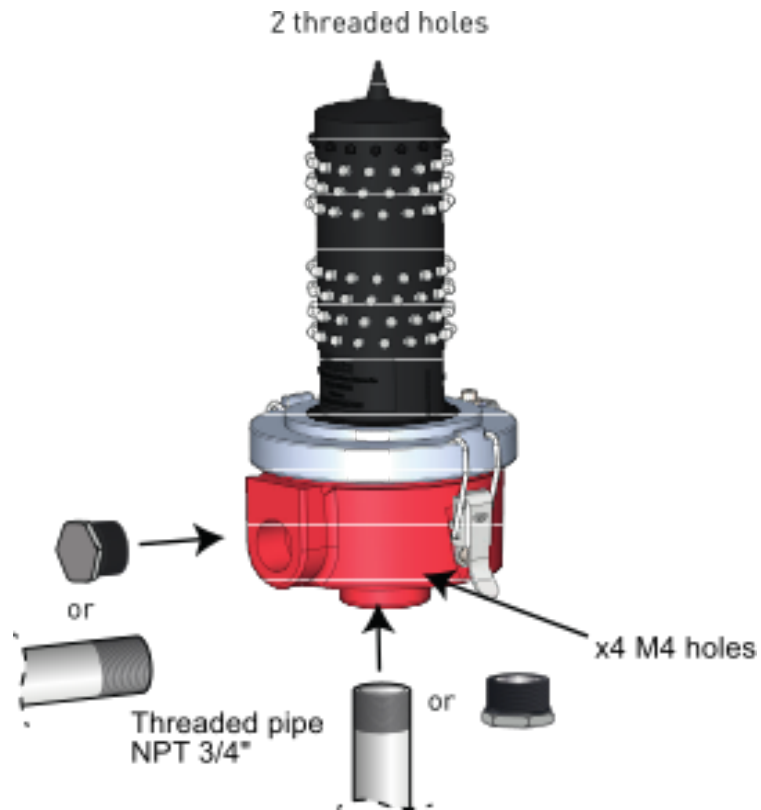

7.4.2 With bracket (P/N-113928)



7.4.3 Square and Ubolt (P/N-113789-NAV-XXX)

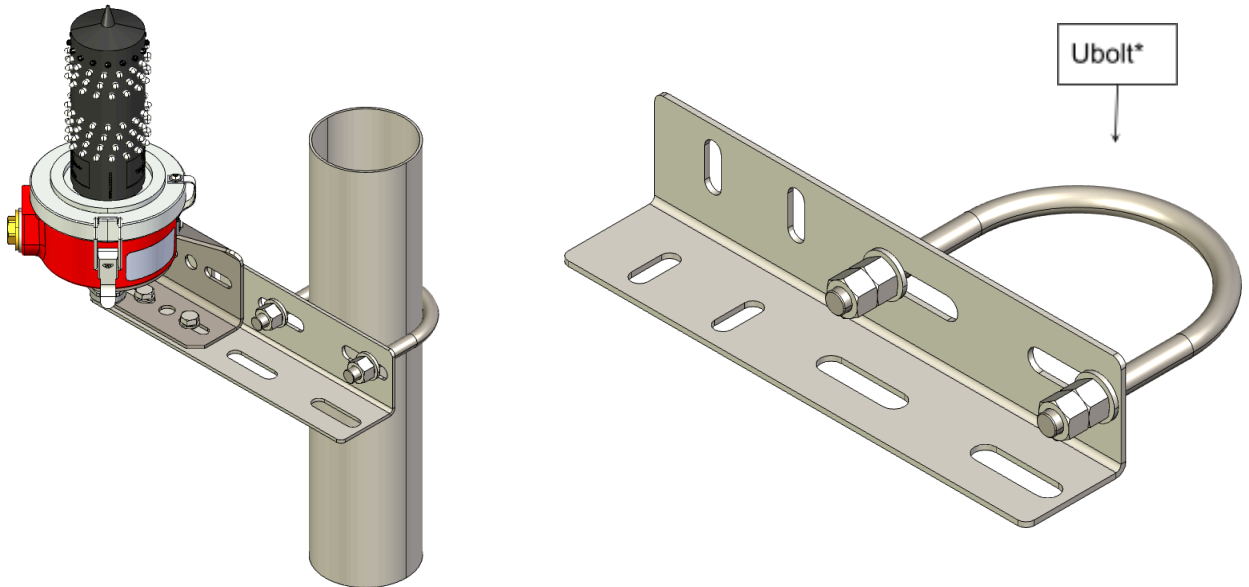

**The size of the U-bolt depends of the size of the support.*

- 50/ 76 mm tube : P/N-113789-NAV-76
- 75/114 mm tube: P/N-113789-NAV-114
- 114/ 273 mm tube: P/N-113789-NAV-273

8. Maintenance

Test	Frequency	Préventive action	Risk
Wiring	Annual	Visual control Tightening cable glands Tightening PCB wires	Cable dégradation Poor contact Lamp in fault mode
Waterproof	Annual	Lamp visual verification	Water infiltration Short circuit Lamp off
Light performance	Annual	Verification of external Clean beacon Check lamp default	Poor brightness Lamp in fault mode
Clamping	Annual	Checking tightness	Lamp falling Tightness degradation
Aspect (rust, dust...)	Annual	Exterior cleaning Check if resin bleaches over time	Malfunction

Before opening the lamp and carrying out any work, check that there is no current in the lamp.

9. Default

Default	Condition of default	Check	Impact
Power supply	<ul style="list-style-type: none"> Lamp in default mode Short led signal 	<ul style="list-style-type: none"> Take the voltage at the input terminals and then at the lamp output terminals. Still in default after a reset 	Change PCB
Lamp current	<ul style="list-style-type: none"> Led dysfunction Lamp in default mode Signal led at the same time as the lamp flash 	<ul style="list-style-type: none"> Still in default after a reset 	Change PCB
Slave synchronization Only for L-810(F)(L)	<ul style="list-style-type: none"> Lamp in default mode Long led signal followed by a short signal 	<ul style="list-style-type: none"> Check continuity and absence of short circuits Still in default after a reset 	Change PCB
Lamp dysfunction	<ul style="list-style-type: none"> On the lamp, Red or IR led no longer light up 	<ul style="list-style-type: none"> Take the voltage at the input terminals and then at the lamp output terminals. State of the lamp 	Replace the PCB, if the lamp still doesn't work, replace the lamp part.

10. Wiring

Wiring example with OFC or OFP product to mimic flash rate and flash duration.
Check switch configuration before energizing all beacons.

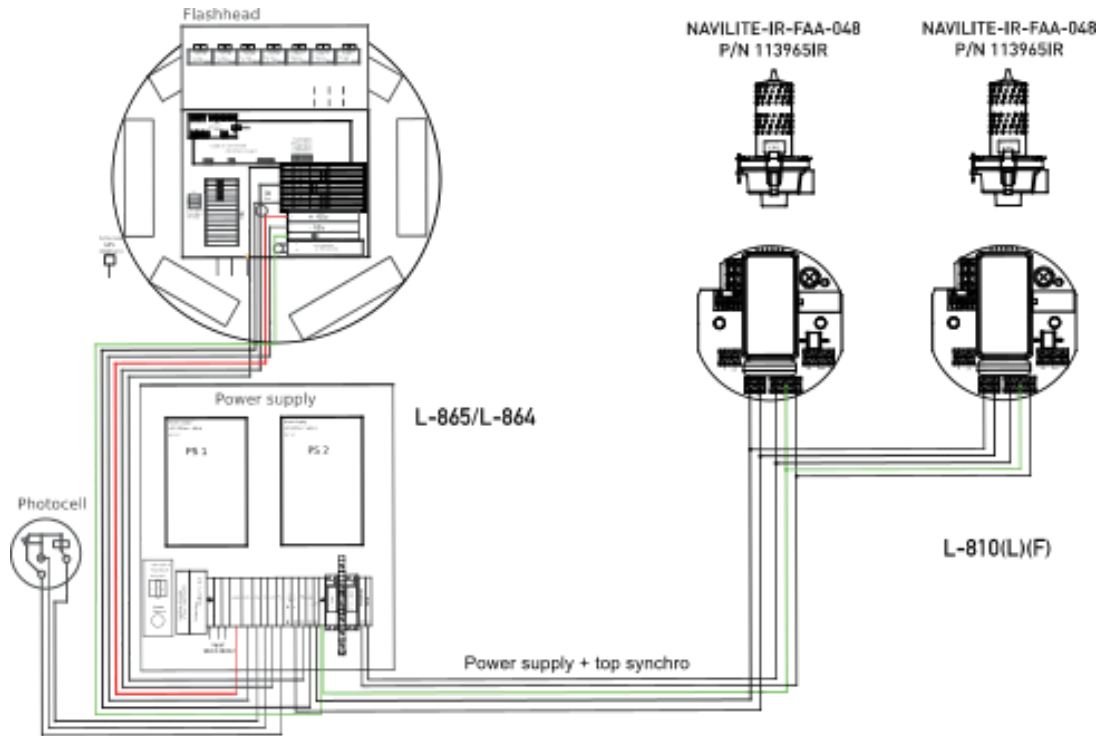

L-864 & L-865/L-864 OBSTAFLASH OFP/OFI 120/240Vac with L-810(L)(F)

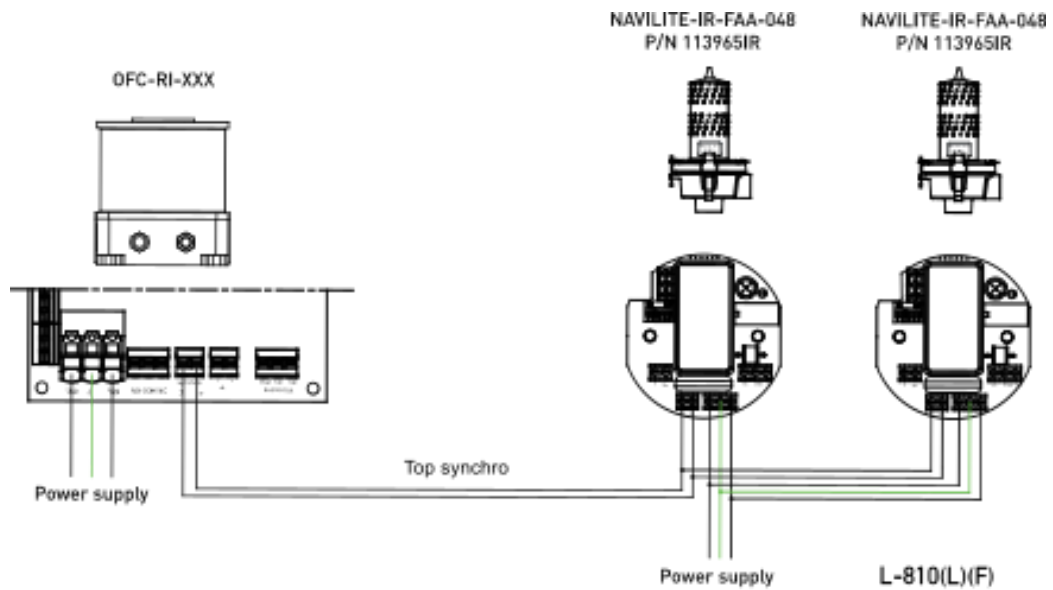

L-864 with L-810(L)(F)