

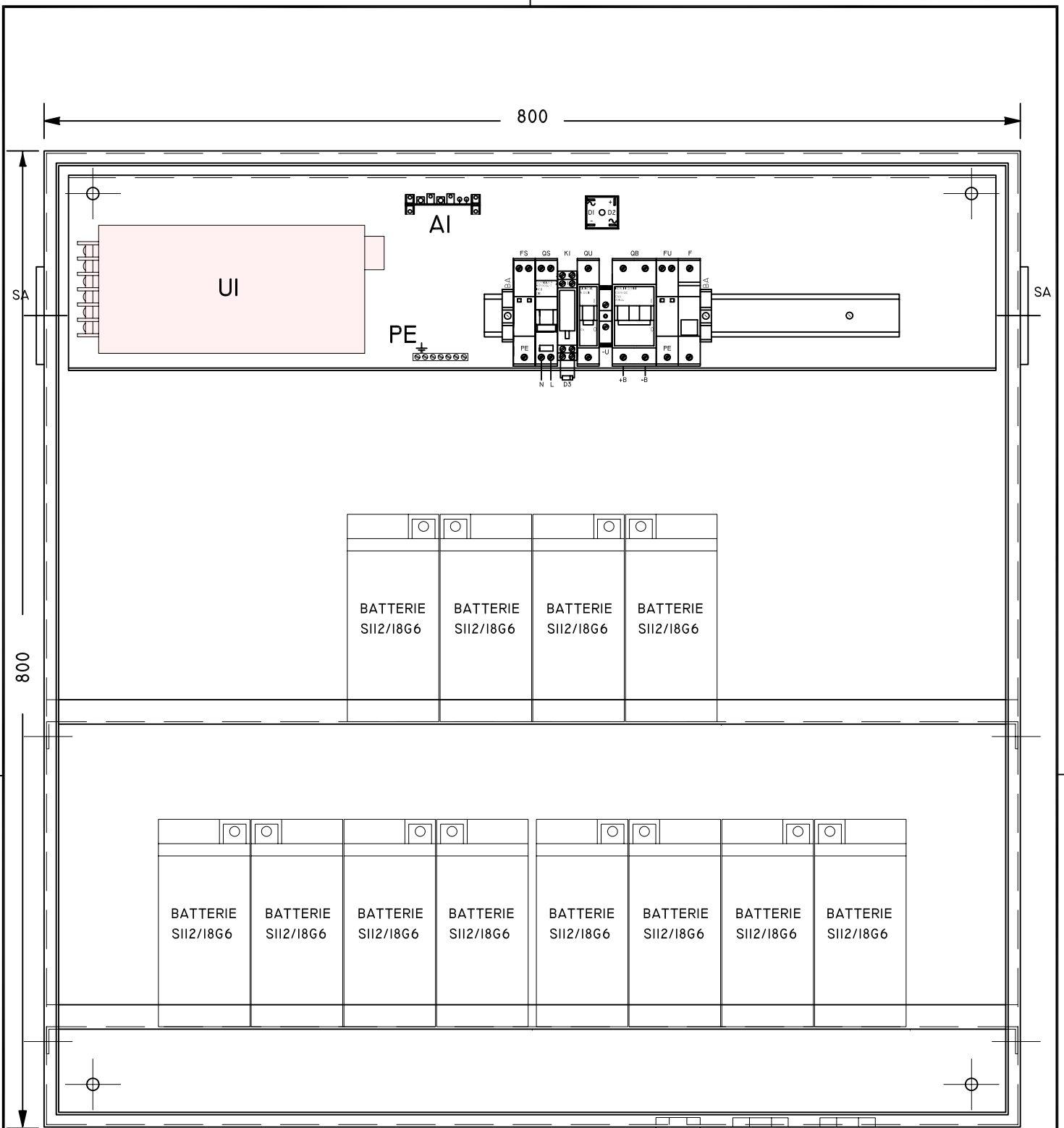

COFFRET "ALIMENTATION" 48Vdc 600W

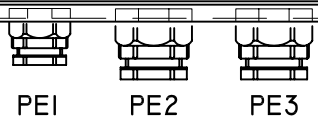

COFFRET "ALIMENTATION" 48Vdc 600W	LONGUEUR: 800 MM
	LARGEUR: 800 MM
	PROFONDEUR: 260 MM
	POIDS: 103.5 Kg



	Ed.1 :	Ed.2 :	Ed.3 :	Ed.4 :	Ed.5 :	E.S :	ECHELLE / SCALE :		
MISE À JOUR : UPDATE :	17/09/20					TOLÉRANCE : TOLERANCE :	ISO 2768-M	FORMAT : SIZE : A4-V	
DESSINÉ PAR : DRAWING BY :	T.BARDOT					FOLIO			
VÉRIFIÉ PAR : APPROVED BY :	J.CARELLA					1/1			

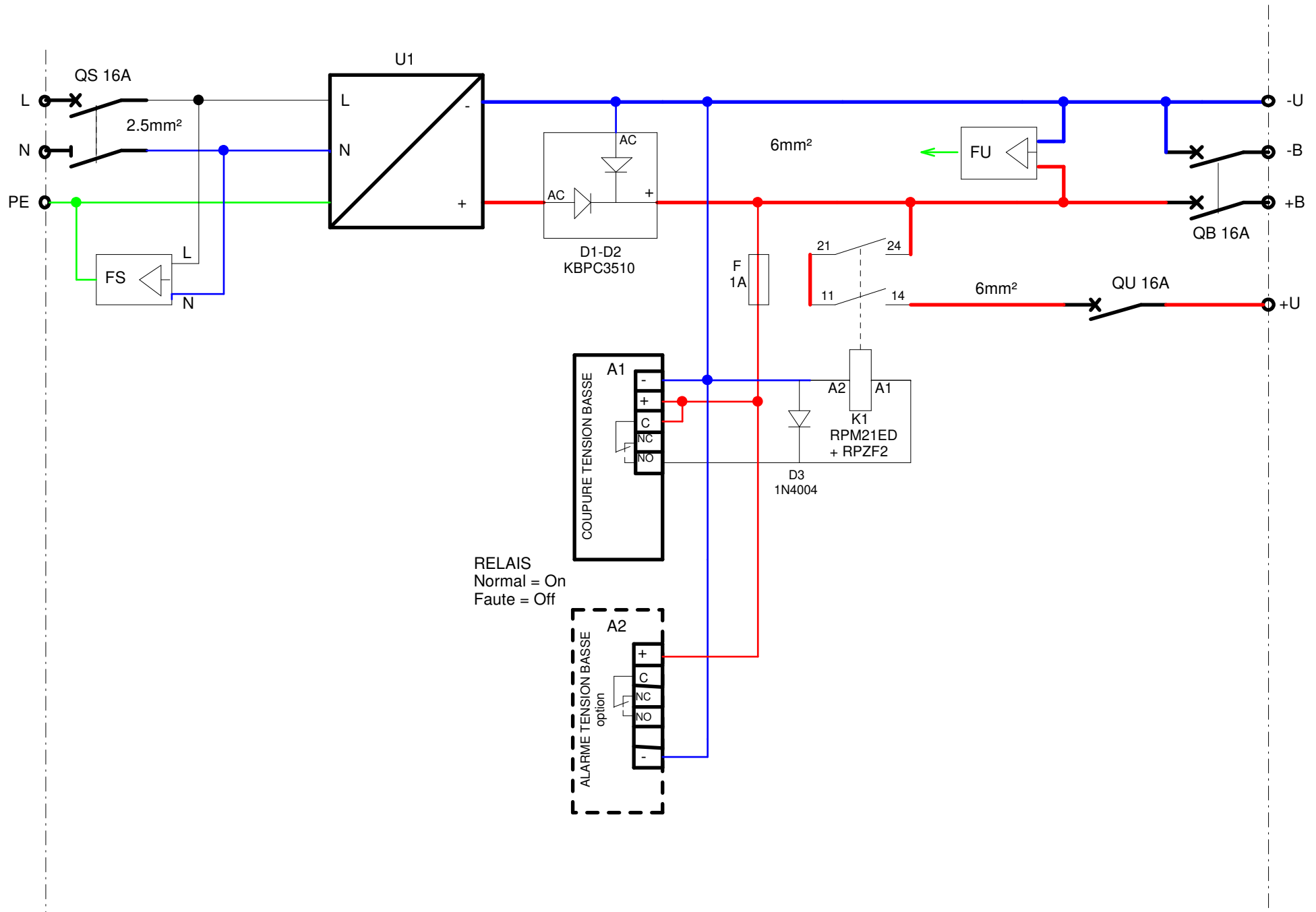

RELAIS
 Normal = On
 Faute = Off

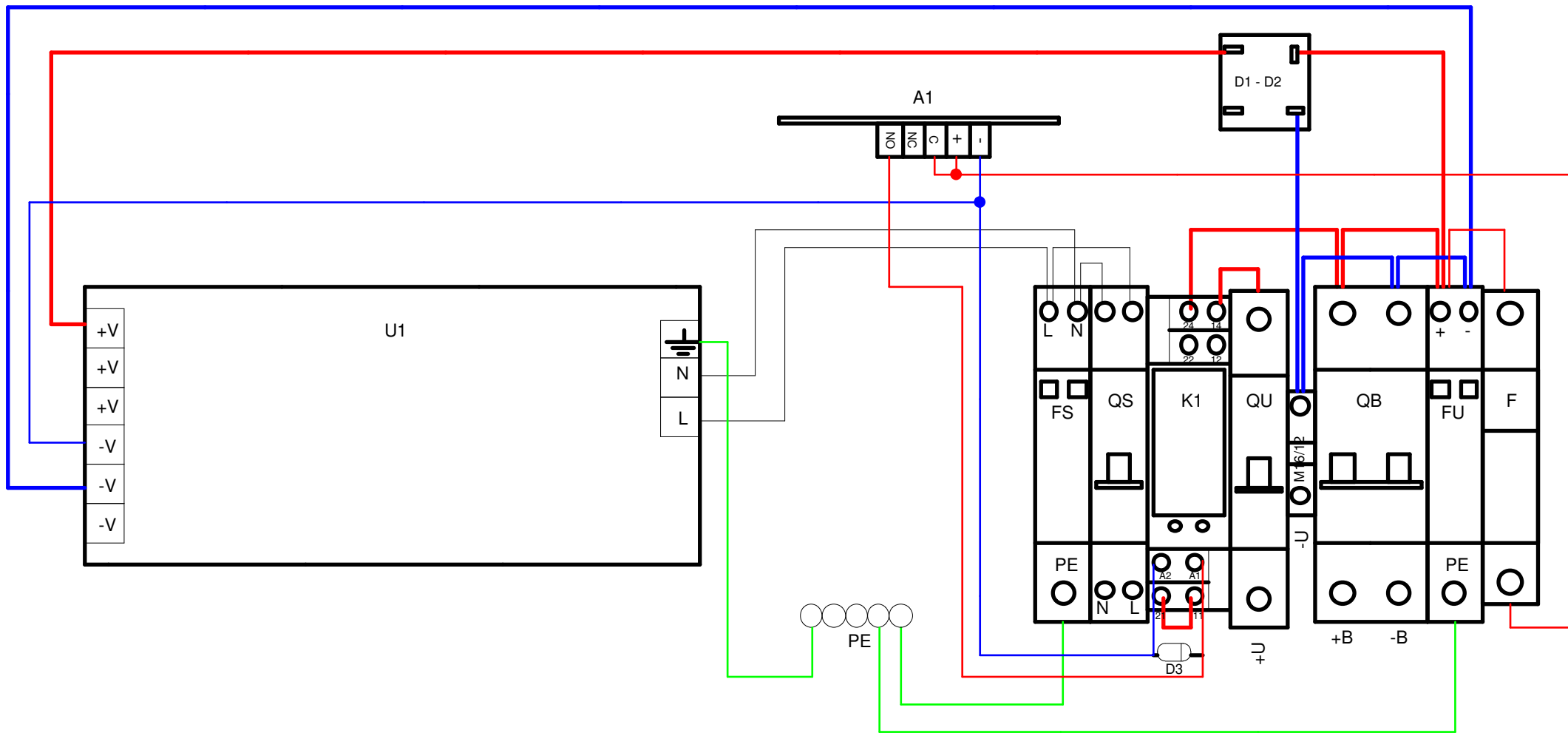

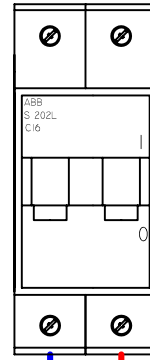

ETAGE 2
BATTERIE

ARRIERE

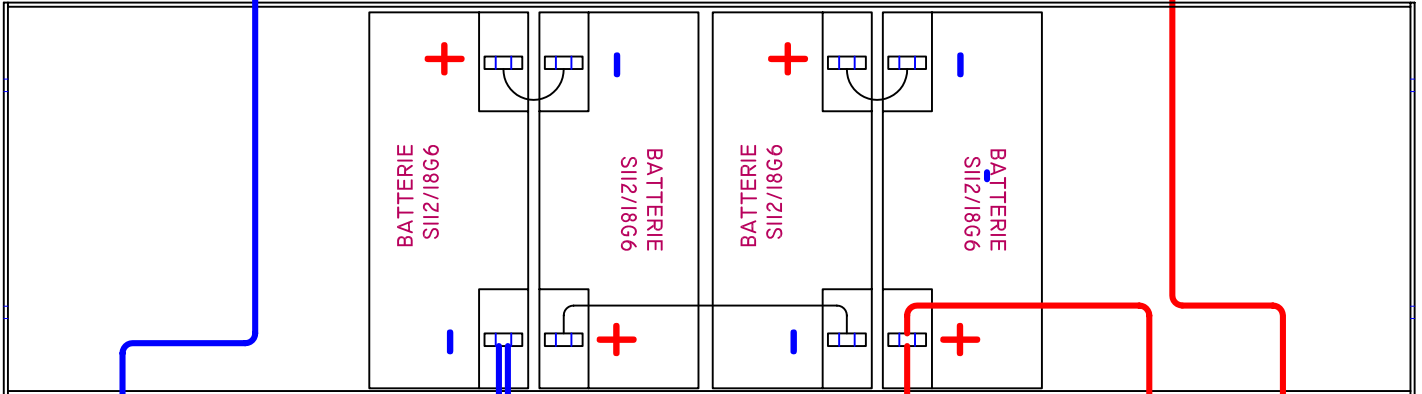



AVANT

ETAGE 1
BATTERIE

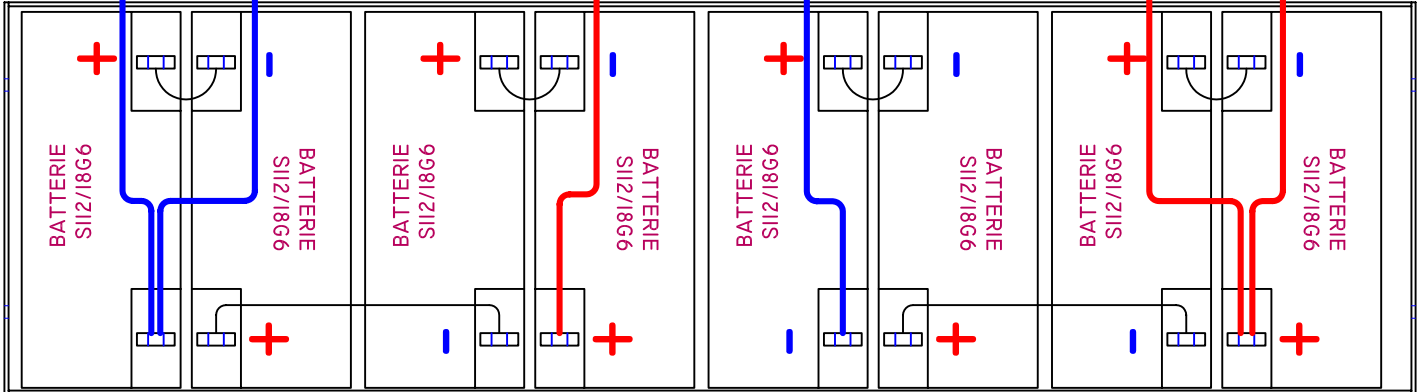
ARRIERE



AVANT

	Ed.1 :	Ed.2 :	Ed.3 :	Ed.4 :	Ed.5 :	E.S :	Echelle / Scale :
MISE À JOUR : CORRECTION :	17/09/20					TOLÉRANCE : TOLERANCE :	FORMAT : SIZE : A4-V  
DESSINÉ PAR : PREPARED BY :	T.BARDOT					FOLIO	
VÉRIFIÉ PAR : APPROVED BY :	J.CARELLA					1/1	

COFFRET "ALIMENTATION" 48Vdc 600W
CÂBLAGE BATTERIES



AS 0445 P2



■ Features :

- Universal AC input / Full range
- Built-in active PFC function, PF>0.94
- High efficiency up to 89%
- Withstand 300VAC surge input for 5 seconds
- Protections: Short circuit / Overload / Over voltage / Over temperature
- Built-in constant current limiting circuit
- Built-in cooling fan ON-OFF control
- Built-in DC OK signal
- Built-in remote sense function
- All using 105°C long life electrolytic capacitors
- 5 years warranty



SPECIFICATION

MODEL	HRP-600-3.3	HRP-600-5	HRP-600-7.5	HRP-600-12	HRP-600-15	HRP-600-24	HRP-600-36	HRP-600-48		
OUTPUT	DC VOLTAGE	3.3V	5V	7.5V	12V	15V	24V	36V	48V	
	RATED CURRENT	120A	120A	80A	53A	43A	27A	17.5A	13A	
	CURRENT RANGE	0 ~ 120A	0 ~ 120A	0 ~ 80A	0 ~ 53A	0 ~ 43A	0 ~ 27A	0 ~ 17.5A	0 ~ 13A	
	RATED POWER	396W	600W	600W	636W	645W	648W	630W	624W	
	RIPPLE & NOISE (max.) Note.2	100mVp-p	100mVp-p	100mVp-p	120mVp-p	150mVp-p	150mVp-p	200mVp-p	240mVp-p	
	VOLTAGE ADJ. RANGE	2.8 ~ 3.8V	4.3 ~ 5.8V	6.8 ~ 9V	10.2 ~ 13.8V	13.5 ~ 18V	21.6 ~ 28.8V	28.8 ~ 39.6V	40.8 ~ 55.2V	
	VOLTAGE TOLERANCE Note.3	±2.0%	±2.0%	±2.0%	±1.0%	±1.0%	±1.0%	±1.0%	±1.0%	
	LINE REGULATION	±0.5%	±0.5%	±0.5%	±0.3%	±0.3%	±0.2%	±0.2%	±0.2%	
	LOAD REGULATION	±1.0%	±1.0%	±1.0%	±0.5%	±0.5%	±0.5%	±0.5%	±0.5%	
	SETUP, RISE TIME	1800ms, 50ms/230VAC 3600ms, 50ms/115VAC at full load								
HOLD UP TIME (Typ.)	16ms/230VAC 16ms/115VAC at full load									
INPUT	VOLTAGE RANGE Note.5	85 ~ 264VAC 120 ~ 370VDC								
	FREQUENCY RANGE	47 ~ 63Hz								
	POWER FACTOR (Typ.)	PF>0.94/230VAC PF>0.99/115VAC at full load								
	EFFICIENCY (Typ.)	78.5%	82%	87%	88%	88%	88%	89%	89%	
	AC CURRENT (Typ.)	7.6A/115VAC 3.6A/230VAC								
	INRUSH CURRENT (Typ.)	35A/115VAC 70A/230VAC								
	LEAKAGE CURRENT	<1.2mA / 240VAC								
PROTECTION	OVERLOAD	105 ~ 135% rated output power Protection type : Constant current limiting, recovers automatically after fault condition is removed								
	OVER VOLTAGE	3.96 ~ 4.62V	6 ~ 7V	9.4 ~ 10.9V	14.4 ~ 16.8V	18.8 ~ 21.8V	30 ~ 34.8V	41.4 ~ 48.6V	57.6 ~ 67.2V	
	OVER TEMPERATURE	Shut down o/p voltage, recovers automatically after temperature goes down								
FUNCTION	DC OK SIGNAL	PSU turn on : 3.3 ~ 5.6V ; PSU turn off : 0 ~ 1V								
	FAN CONTROL (Typ.)	Load 35 ± 15% or RTH2 ≥ 50°C Fan on								
ENVIRONMENT	WORKING TEMP.	-40 ~ +70°C (Refer to "Derating Curve")								
	WORKING HUMIDITY	20 ~ 90% RH non-condensing								
	STORAGE TEMP., HUMIDITY	-40 ~ +85°C, 10 ~ 95% RH non-condensing								
	TEMP. COEFFICIENT	±0.03%/°C (0 ~ 50°C)								
	VIBRATION	10 ~ 500Hz, 5G 10min./1cycle, 60min. each along X, Y, Z axes								
SAFETY & EMC (Note 4)	SAFETY STANDARDS	UL60950-1, TUV EN60950-1, EAC TP TC 004 approved								
	WITHSTAND VOLTAGE	I/P-O/P:3KVAC I/P-FG:2KVAC O/P-FG:0.5KVAC								
	ISOLATION RESISTANCE	I/P-O/P, I/P-FG, O/P-FG:100M Ohms / 500VDC / 25°C / 70% RH								
	EMC EMISSION	Compliance to EN55032 (CISPR32) Class B, EN61000-3-2,-3, EAC TP TC 020								
	EMC IMMUNITY	Compliance to EN61000-4-2,3,4,5,6,8,11, EN55024, EN61000-6-2, heavy industry level, criteria A, EAC TP TC 020								
OTHERS	MTBF	140.6K hrs min. MIL-HDBK-217F (25°C)								
	DIMENSION	218*105*63.5mm (L*W*H)								
	PACKING	1.5Kg;8pcs/13Kg/1.34CUFT								
NOTE	<p>1. All parameters NOT specially mentioned are measured at 230VAC input, rated load and 25°C of ambient temperature.</p> <p>2. Ripple & noise are measured at 20MHz of bandwidth by using a 12" twisted pair-wire terminated with a 0.1uf & 47uf parallel capacitor.</p> <p>3. Tolerance : includes set up tolerance, line regulation and load regulation.</p> <p>4. The power supply is considered a component which will be installed into a final equipment. All the EMC tests are been executed by mounting the unit on a 360mm*360mm metal plate with 1mm of thickness. The final equipment must be re-confirmed that it still meets EMC directives. For guidance on how to perform these EMC tests, please refer to "EMI testing of component power supplies." (as available on http://www.meanwell.com)</p> <p>5. Derating may be needed under low input voltages. Please check the derating curve for more details.</p> <p>6. The ambient temperature derating of 3.5°C/1000m with fanless models and of 5°C/1000m with fan models for operating altitude higher than 2000m(6500ft).</p>									

Mechanical Specification

Case No. 977A Unit:mm

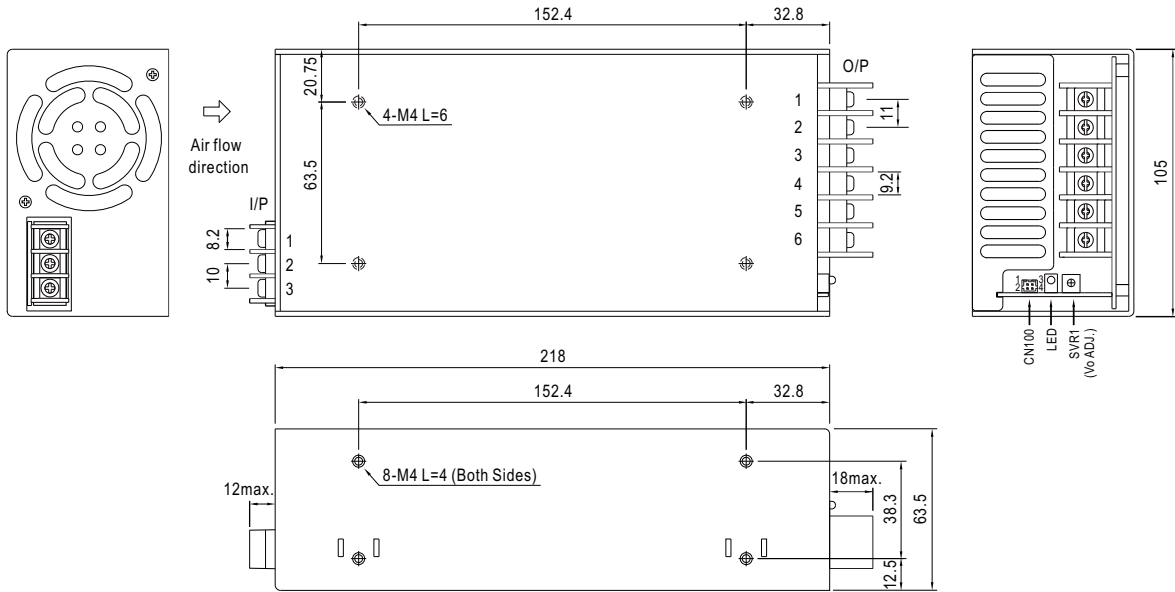

AC Input Terminal Pin No. Assignment

Pin No.	Assignment
1	AC/L
2	AC/N
3	FG \perp

DC Output Terminal Pin No. Assignment

Pin No.	Assignment
1~3	-V
4~6	+V

Connector Pin No. Assignment(CN100) : HRS DF11-4DP-2DS or equivalent

Pin No.	Assignment	Mating Housing	Terminal
1	DC-OK	HRS DF11-4DS or equivalent	HRS DF11-**SC or equivalent
2	GND		
3	+S		
4	-S		

Block Diagram

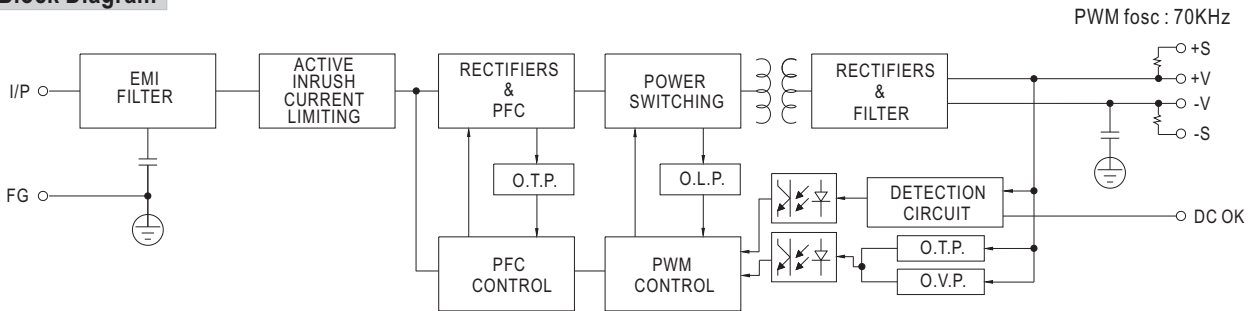

Derating Curve

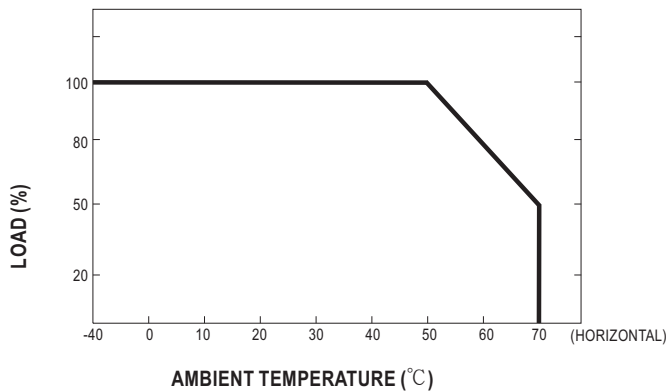

Output Derating VS Input Voltage

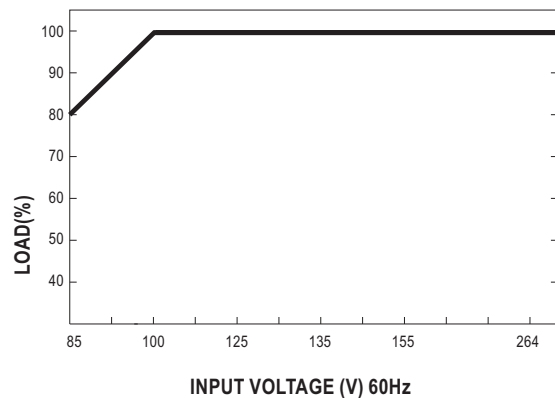

Industrial Batteries / Network Power

Powerfit S100



»The compact energy package
 for more security«

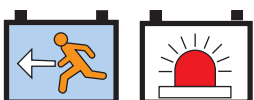

Powerfit[®]

Powerfit S100

The compact all-rounder

GNB's Powerfit S100 are general purpose batteries designed to deliver high performance in case of power interruptions. They are the ideal solution for applications such as security & alarm systems, emergency lighting, signaling, and any other UPS application where compact and reliable back-up power is key.

Specifications:

- > Rechargeable VRLA batteries in which the electrolyte is fixed in a glass mat (with very fine glass fibres)
- > Perfect combination of energy storage performance and reliability
- > Maintenance-free (no topping up) during the whole service life
- > Nominal capacity 1.2 – 38 Ah
- > 3-5 years design life at 20 °C ambient temperature (80% re-maining capacity)
- > Container in ABS Material
- > Designed in accordance with IEC 60896-21/22
- > Grid plate construction consisting of a lead calcium alloy
- > Low gas emission due to high gas recombination of 99%
- > Low self-discharge rate (about 3% / month at 20 °C)
- > Trouble-free transport of operational blocks, no restrictions for rail, road, sea and air transportation (IATA, DGR clause A67)
- > Completely recyclable

Technical characteristics and data

Type	Part number	Nom-voltage V	Nom. capacity C ₂₀ 1.80 Vpc 25 °C Ah	C ₁₀ 1.75 Vpc 25 °C Ah	C ₁ 1.6 Vpc 25 °C Ah	Length* (l) mm	Width* (b/w) mm	Height* (h) mm	Weight ca. kg	Internal-resistance acc. to IEC 60896-21 mΩ	Max. discharge current f. 5 sec. A	Terminal
S106/1.2 S	NAS10601D2VW0SA	6	1.20	1.14	0.73	97.0	24.0	57.5	0.29	65.0	18.0	S-4.8
S106/4.5 S	NAS10604D5VW0SA	6	4.50	4.27	2.73	70.0	47.0	106	0.81	25.0	67.5	S-4.8
S106/12 SR	NAS1060012VW0RA	6	12.0	11.5	7.54	151	51.0	100	1.80	15.0	180	SR-6.3
S112/1.2 S	NAS11201D2VW0SA	12	1.20	1.14	0.73	97.0	43.0	58.0	0.57	90.0	18.0	S-4.8
S112/1.9 S	NAS11201D9VW0SA	12	1.90	1.80	1.15	178	35.0	65.0	0.87	80.0	28.5	S-4.8
S112/4.5 S	NAS11204D5VW0SA	12	4.50	4.27	2.73	90.0	70.0	107	1.48	40.0	67.5	S-4.8
S112/7.2 S	NAS11207D2VW0SA	12	7.20	6.82	4.44	151	65.0	99.0	2.35	22.0	108	S-4.8
S112/7.2 SR	NAS11207D2VW0RA	12	7.20	6.82	4.44	151	65.0	99.0	2.35	22.0	108	SR-6.3
S112/9 SR	NAS1120009VW0RA	12	9.00	8.06	5.31	151	65.0	99.0	2.45	18.0	127.5	SR-6.3
S112/12 S	NAS1120012VW0SA	12	12.0	11.5	7.54	151	98.0	101	3.50	14.0	180	S-4.8
S112/12 SR	NAS1120012VW0RA	12	12.0	11.5	7.54	151	98.0	101	3.50	14.0	180	SR-6.3
S112/18 G6	NAS1120018VW0BA	12	18.0	17.2	11.3	181.5	77.0	167.5	5.40	16.0	270	G-M6
S112/26 G6	NAS1120026VW0BA	12	26.0	24.8	16.3	166	175	125	8.00	14.0	390	G-M6
S112/38 F6	NAS1120038VW0FA	12	38.0	38.0	23.2	197	165	170	12.20	10.0	456	F-M6

* ±2 mm



Nominal capacity
1.2 – 38 Ah
C₂₀



Block battery



Grid plate



Recyclable



Valve regulated
lead-acid
batteries



Maintenance-free (no
topping up)

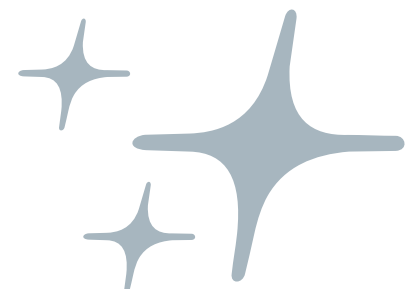

Powerfit S100

The compact energy source with high performance

Dimensions

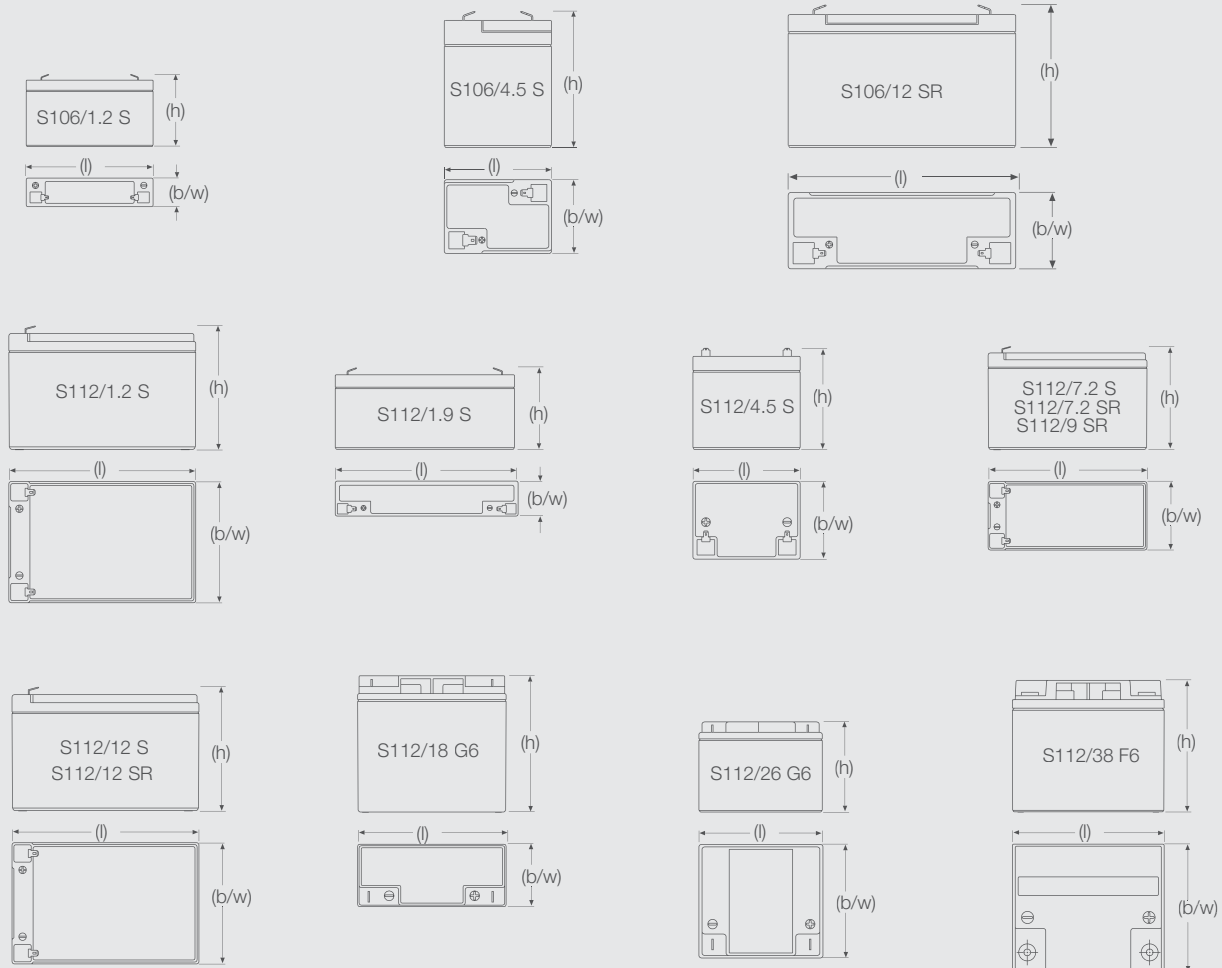

Container and terminal

> Container: ABS



Applications

In addition to their suitability for general applications in security systems, the Powerfit S100 batteries are a reliable energy source for emergency lighting.