

On specific demand. the spherical bird flight diverter 400mm diameter is designed to make overhead cables visible to birds during day time

Solution derived from field-proven aircraft 600mm warning spheres

- Diameter: 400mm
- Color: Black and yellow per hemisphere (other colors available upon request)
- Marker spacing to be confirmed depending on the context
- Material: Painted aluminum
- Designed for high-voltage, high-temperature cables
- Quick installation with 2 captive bolts and stainless steel toggle latches
- Clamps adapted to the cable diameter
- Installation possible with or without armor rods (reinforcement lining)
- Slip resistance up to 40kg

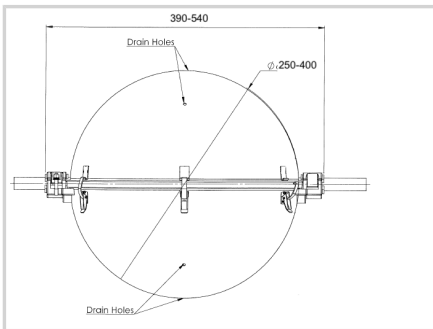

Mechanical Characteristics

Cable diameter	ø14,0 to 59,8mm to be specified at time order
Maximum cable temperature	250°C peak
Color	yellow and black
Weight	4kg