

## Dual color OBSTAFLASH medium intensity type A and B or C

### Flashhead

- 6 led projectors in aluminium and glass
- 2 white led circuits and a red and infrared circuit inside each projector
- Simple installation with no losing parts when opening the flash-head
- Normally open or normally close relay in case of lamp default or power supply
- Communication capabilities (controller, Modbus TCP)
- Test button for day and night
- Luminous indicators for quick diagnostic
- 48Vdc surge protection with indicator showing when it has failed included
- GPS controlled or activated in case of failure or absence of an external controller or/and photocell

### Power supply

- 'Weather tight' stainless steel 316L power cabinet enclosure
- Connection to the controller OFH-CTR-CAN

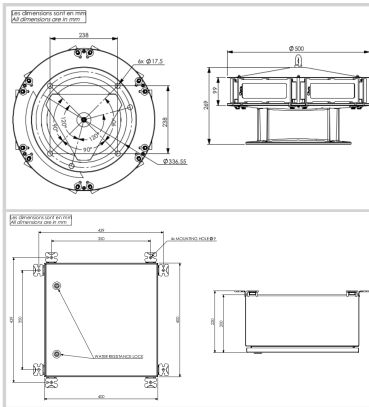

Electrical Characteristics	
Main voltage	110VAC to 240VAC +/-10% 50/60Hz
Average wattage	55W (day time), 8W (night mode)
Mechanical Characteristics	
IP degree	IP66 per projector
Wiring	Entry of cable by glands nickel plated brass and connection by terminals
Operating temperature	-40/+55°C
Weight	24 kg
Weight	24 kg
Size of the light	333mm (height) x 500mm (diameter)
Size of the power supply	590mm (height) x 350mm (width) x 250mm (dept)
Wire cross section	from 1 to 4 mm <sup>2</sup>
Attachment	6 mounting holes dia.16mm, dia.337mm circle (FAA standard)
Photometric Characteristics	
Effective light output day time at 0° on site	20 000cd (white)
Effective light output twilight mode at 0° on site	20 000cd (white)
Effective light output night mode at 0° on site	2000cd (red) with IR
Color day/twilight time	white
Color night time	Red
Vertical beam spread	>3°
Horizontal beam spread	360°
Flash per minute	20, 30, 40 or 60 flashes per minute
Standards	
Standards compliance	ICAO annexe 14 chapter 6 (8th edition 07/2018), EASA (4th edition 2017)