

The obsta spherical markers are compliant with International Civil Aviation Organisation (ICAO) annex 14 chapter 6 recommendations.

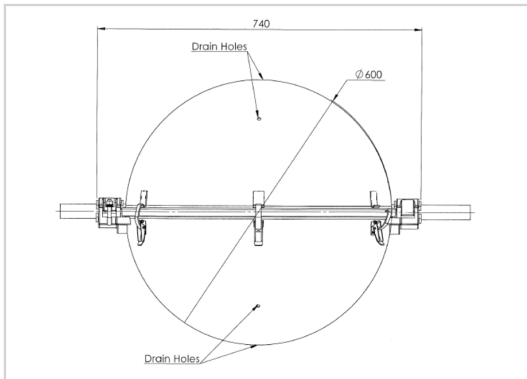

- ✦ overall diameter 600mm
- ✦ material: aluminium
- ✦ Designed for high voltage cable up to 400KV
- ✦ No losing parts and easy installation with only 2 screws and draw latches



| Mechanical Characteristics |                      |
|----------------------------|----------------------|
| Cable diameter             | $\phi$ 22,90-24,70mm |
| Color                      | White                |