

Red medium intensity FAA L-864 (AC 150/5345-43J) ETL certified

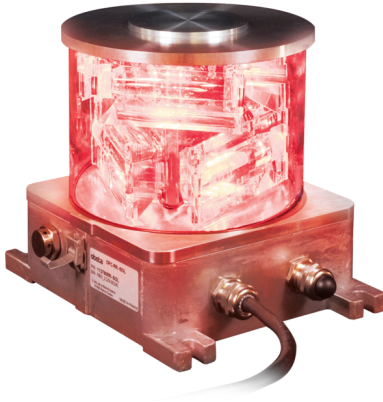

1966535B1 & US 7816843

Patents: EP

Flash-head with integrated power supply

- ✦ 6 Obsta optics with cover in hard glass and aluminium base
- ✦ Simple installation with no losing parts when opening the flash-head
- ✦ Power supply inside the flash-head
- ✦ NVG compatible (with IR)
- ✦ Alarm in compliance with FAA Engineering Brief 98
- ✦ Surge protection with indicator showing when it has failed included
- ✦ membrane vent
- ✦ Top sync for optional side lights L-810(L)(F) NAVILITE-IR-FAA-120-240V P/N113969IR
- ✦ GPS and internal photocensor in option
- ✦ Choice of the configurations (ICAO medium intensity type B (20, 30, 40, 50 ou 60 flashes per minute) or ICAO medium intensity type C or FAA L-864) through dip-switches inside the light, to be specified at time order



Option provided with GPS (day/night sync and/or flash sync)

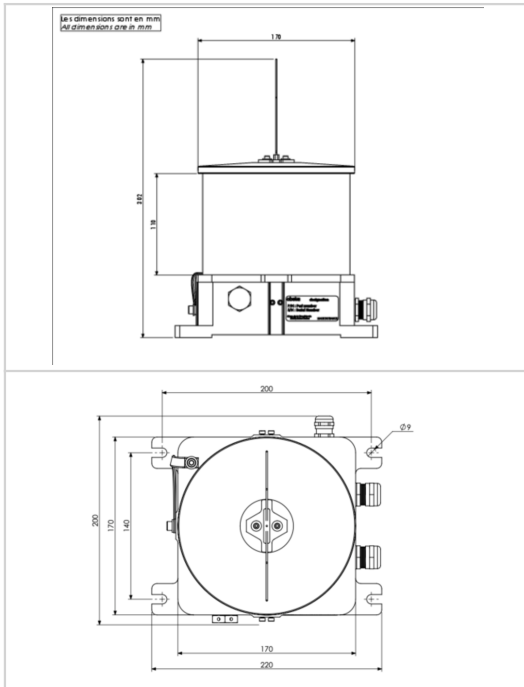

Electrical Characteristics	
Main voltage	110VAC to 240VAC +/-10% 50/60Hz
Average wattage	10W (ICAO and FAA configuration @ 30 flashes per minute)
Mechanical Characteristics	
IP degree	IP66
Wiring	Entry of cable by glands nickel plated brass and connection by terminals
Operating temperature	-40/+55°C
Weight	4 kg
Size of the light	220mm x 190mm x 190mm
Weight	5kg
Cable entry diameter	from 7 to 13 mm
Wire cross section	up to 6mm <sup>2</sup> for power supply, up to 1,5mm <sup>2</sup> for signal
Attachment	4 mounting holes dia.9mm, 200mm x 140mm
Photometric Characteristics	
IR intensity and wavelength	> 600mW/sr @ 800-900nm
Effective light output night mode at 0° on site	2000cd (red) with IR
Color night time	Red
Vertical beam spread	>3°
Horizontal beam spread	360°
Flash per minute	30
Standards	
Standards compliance	ICAO annex 14 chapter 6, FAA (AC 150/5345-43J), UK MOD, Transport Canada
Certification	FAA (AC 150/5345-43J), ETL listed, DGAC(Fr)